

SN54157, SN54LS157, SN54S157, SN54LS158, SN54S158, SN74157, SN74LS157, SN74S157, SN74LS158, SN74S158  
 QUADRUPLE 2-LINE TO 1-LINE DATA SELECTORS/MULTIPLEXERS

MARCH 1974 - REVISE: J MARCH 1988

- Buffered Inputs and Outputs
- Three Speed/Power Ranges Available

TYPES	TYPICAL AVERAGE PROPAGATION TIME	TYPICAL POWER DISSIPATION
*157	9 ns	110mW
*LS157	9 n*	49mW
*S157	5m	250mW
*LS158	7 n>	24mW
*S158		195mW

applications

- Expand Any Data Input Point
- Multiplex Dual Data Buses
- Generate Four Functions of Two Variables (One Variable Is Common)
- Source Programmable Counters

description

These monolithic data selectors/multiplexers contain inverters and drivers to supply full on-chip data selection to the four output gates. A separate strobe input is provided. A 4-bit word is selected from one of two sources and is routed to the four outputs. The \*157, \*LS157, and \*S157 present true data whereas the \*LS158 and \*S158 present inverted data to minimize propagation delay time.

FUNCTION TABLE

SELECT A/B	INPUTS		OUTPUT Y	
	A	B	*157, *LS157, *S157	*LS158, *S158
X	X	X	L	H
L	L	X	L	H
L	H	X	H	L
H	X	L	L	H
H	X	H	H	L

H = high level, L = low level, X = irrelevant

absolute maximum ratings over operating free-air temperature range (unless otherwise noted)

Supply voltage: V <sub>ee</sub> (See Note 1)	.....	7V
Input voltage: *157, *S157, *LS157, *LS158	.....	5.5 V
Operating free-air temperature range: SN54*	.....	-55°C to 125°C
SN74*	.....	0°C to 70°C
Storage temperature range	.....	-65°C to 150°C

NOTE 1: Voltage values are with respect to network ground terminal.

SN54157, SN54LS157, SN54S157, SN54S158, SN54LS158, SN54S158 ... J OR W PACKAGE  
 SN74157 ... N PACKAGE  
 SN74LS157, SN74S157, SN74LS158, SN74S158 ... D OR N PACKAGE

TOP VIEW

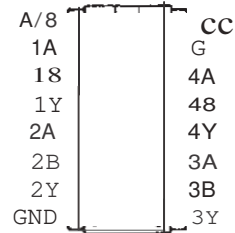

SN54S157, SN54S157, SN54S158, SN54S158 ... FK PACKAGE (TOP VIEW)

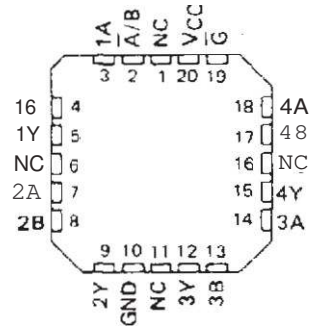

NC - No internal connection

PROVIDE DATA ...

SN54157, SN54LS157, SN54LS158, SN54S157, SN54S158,  
 SN74157, SN74LS157, SN74S157, SN74S158  
 OUAOHUPLE 2-LINE TO 1-LINE DATA SEIECTORSIMULTIPLEXERS

logic symbols'

logic diagram (positive logic)

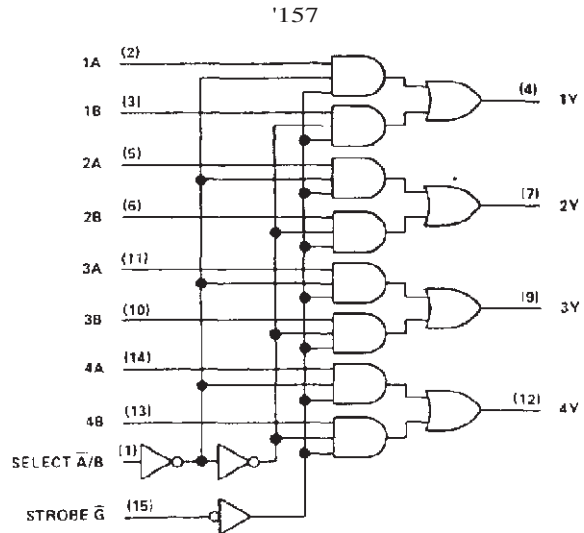
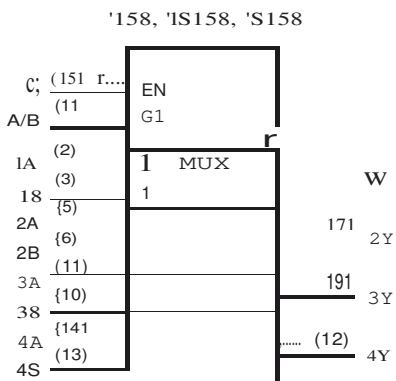
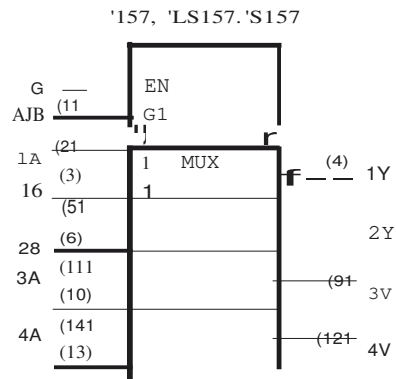

!Thes s-ymbols are in accor<lanc" with ANSI/IEEE Std 91-1984 and IEC Pub ication 617-12  
 f>,n numbers shown are for D, J, N, and W packages.

schem<ttics of inputs and outputs

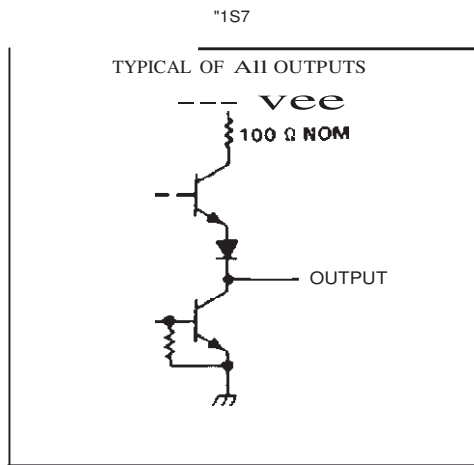
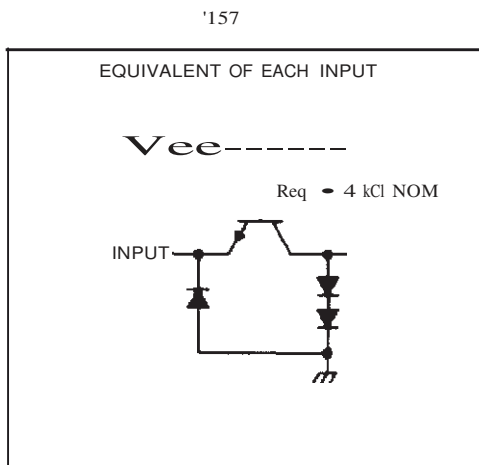

SN54LS157, SN54LS158, SN54S157, SN54S158,  
 SN74LS157, SN74LS158, SN74S157, SN74S158  
 QUADRUPLE 2-LINE TO 1-LINE DATA SELECTORS/MULTIPLEXERS

logic diagrams (positive logic)

schematics of inputs and outputs

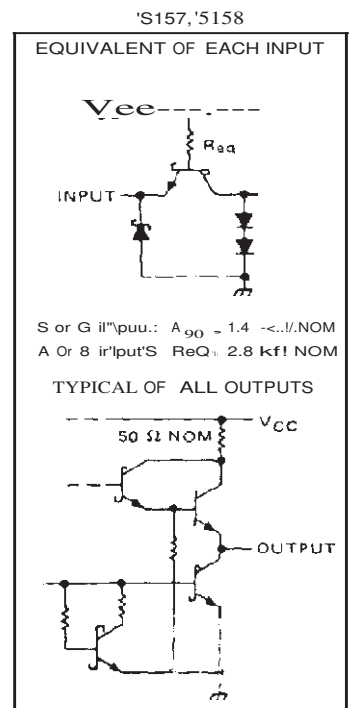
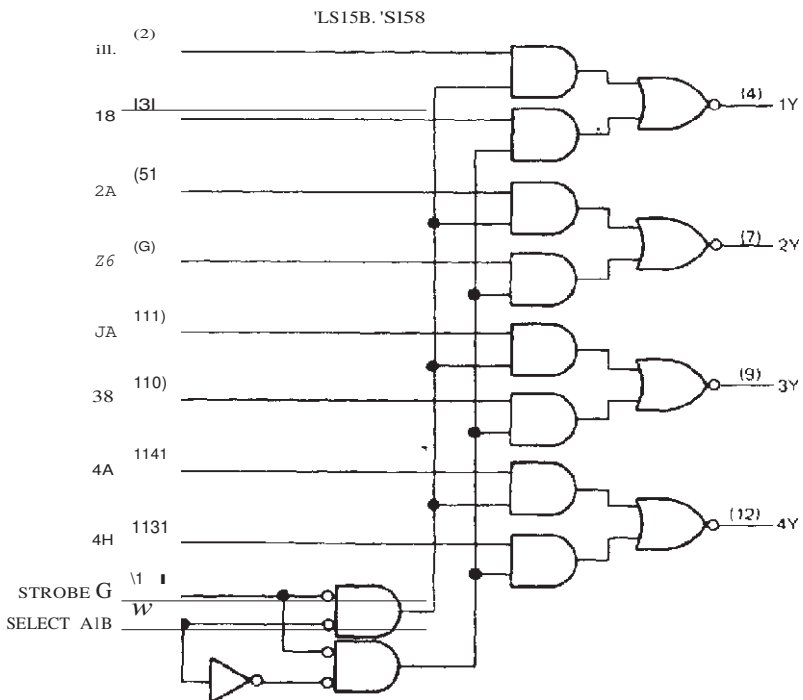
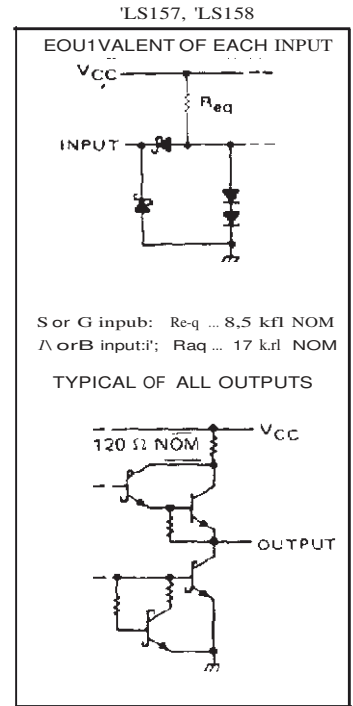
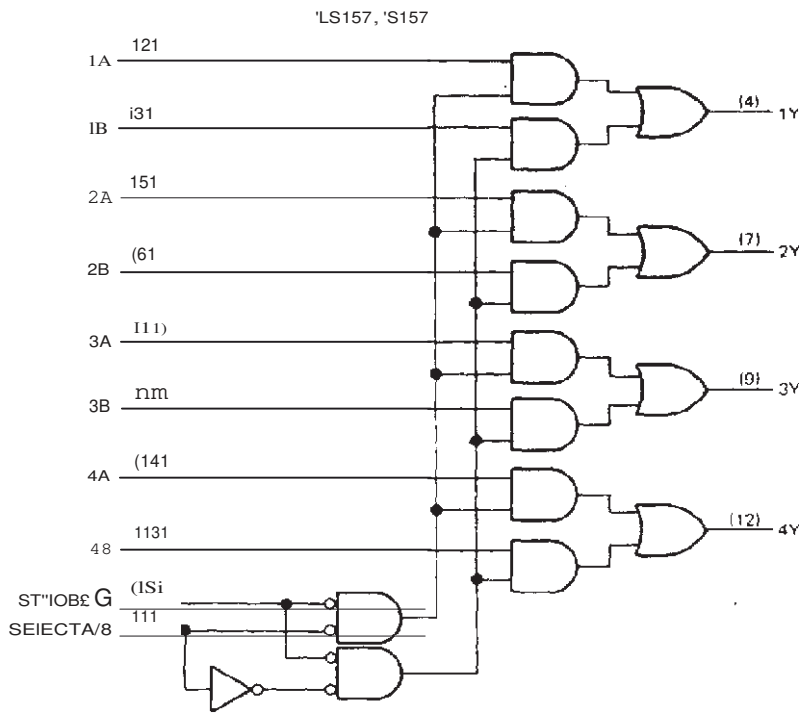

Pin numbers shown are for D, J, N, and W packages.

TEXAS  
 INSTRUMENTS

PQ-ST OFF: ct 80X 555012 • J.A.L.L.S. TEXAS 75255

SN54157, SN74157  
 QUADRUPLE 2-LINE TO 1-LINE DATA SELECTORS/MULTIPLEXERS

recommended operating conditions

	SN54157			SN74157			UNIT
	MIN	NOM	MAX	MIN	NOM	MAX	
Supply voltage, $V_{EE}$	4.5	5	5.5	4.75	5	5.25	V
High-level output current, $I_{OH}$			-800			-800	mA
Low-level output current, $I_{OL}$			16			16	mA
Operating free air temperature, $T_A$	-55		125	0		70	$^{\circ}C$

electrical characteristics over recommended operating free-air temperature range (unless otherwise noted)

PARAMETER	TEST CONDITIONS <sup>1</sup>	SN 54157		SN 74157		UNIT
		MIN	TYP <sup>2</sup> MAX	MIN	TYP <sup>2</sup> MAX	
High-level input voltage		2		2		V
$V_{IH}$ Low-level input voltage			0.8		0.8	V
$V_{IK}$ Input clamp voltage	$V_{EE}^{MIN}$ , $I_I = 12 \text{ mA}$		1.5		1.5	V
$V_{OH}$ High-level output voltage	$V_{EE}^{MIN}$ , $V_{IH} = 2 \text{ V}$ , $V_{IL} = 0.8 \text{ V}$ , $I_{OH} = -800 \mu\text{A}$	2.4	3.4	2.4	3.4	V
$V_{OL}$ Low-level output voltage	$V_{EE}^{MIN}$ , $V_{IH} = 2 \text{ V}$ , $V_{IL} = 0.8 \text{ V}$ , $I_{OL} = 16 \text{ mA}$		0.2 0.4		0.2 0.4	V
$I_{IH}$ Input current at minimum input voltage	$V_{EE}^{MAX}$ , $V_I = 5.5 \text{ V}$					mA
$I_{IH}$ High-level input current	$V_{EE}^{MAX}$ , $V_I = 2.4 \text{ V}$		40		40	mA
$I_{IL}$ Low-level input current	$V_{EE}^{MAX}$ , $V_I = 0.4 \text{ V}$		1.6		1.6	mA
$I_{CS}$ Short-circuit output current	$V_{EE}^{MAX}$	-20	-55	-18	55	mA
$I_{CC}$ Supply current	$V_{EE}^{MAX}$ , See Note 2		30 48		30 48	mA

<sup>1</sup> For condition-f, & shown as MIN or MAX, use the appropriate value specified under recommended operating condition. All typical values are at  $V_{EE} = 5 \text{ V}$ ,  $T_A = 25^{\circ}C$ .

<sup>2</sup> Not more than one output should be shorted at a time and duration of short-circuit should not exceed one second.

NOTE 2:  $I_{CC}$  measured at  $V_{EE} = 4.5 \text{ V}$  applied 10 H input, and all outputs open.

switching characteristics,  $V_{EE} = 5 \text{ V}$ ,  $T_A = 25^{\circ}C$

PARAMETER	FROM (INPUT)	TEST CONDITIONS	MIN	TYP	MAX	UNIT
$t_{PLH}$	Data	$C_L = 10 \text{ pF}$ , $R_1 = 400 \Omega$ , See Note 3		9	14	s
$t_{PHL}$				9	14	
$t_{PLH}$	Strobe G			11	20	s
$t_{PHL}$				14	21	
$t_{PLH}$	Select A:B			15	23	ns
$t_{PHL}$				18	27	

$t_{PLH}$  = propagation delay time, low-to-high level output

$t_{PHL}$  = propagation delay time, high-to-low-level output

NOTE 3: load circuits and voltage waveforms as shown in Section 1

TE>AS  
 INSTRUMENTS

POST OFFICE BOX 635012 • DALLAS, TEXAS 75205

SN54LS157, SN54LS158, SN74LS157, SN74LS158  
QUADRUPLE 2-LINE TO 1-LINE DATA SELECTORS/MULTIPLEXERS

recommended operating conditions

	SN54LS <sup>1</sup>			SN74LS <sup>1</sup>			UNIT
	MIN	NOM	MAX	MIN	NOM	MAX	
V <sub>ee</sub> Supply-PIV voltage	4.5	5	5.5	4.75	5	5.25	V
I <sub>OH</sub> High-level output current			-400			-400	mA
I <sub>QL</sub> Low-level output current			4			8	mA
T <sub>A</sub> Operating free-air temperature	-55		125	0		70	°C

electrical characteristics over recommended operating free-air temperature range (unless otherwise noted)

PARAMETER	TEST CONDITIONS <sup>1</sup>	SN54LS <sup>1</sup>		SN74LS <sup>1</sup>		UNIT			
		MIN	TYP <sup>2</sup>	MAX	MIN		TYP <sup>2</sup>	MAX	
V <sub>IH</sub> High-level input voltage		2			2	V			
V <sub>IL</sub> Low-level input voltage			0.7			0.8	V		
V <sub>IK</sub> Input clamp voltage	V <sub>ee</sub> MIN, I <sub>t</sub> = 18mA			-1.5		-1.5	V		
V <sub>OH</sub> High-level output voltage	V <sub>ee</sub> MIN, V <sub>tH</sub> = 2V, V <sub>tL</sub> MAX, I <sub>OH</sub> = 400µA	2.5	3.4		2.7	3.4	V		
V <sub>OL</sub> Low-level output voltage	V <sub>ee</sub> MIN, V <sub>tH</sub> = 2V, I <sub>OL</sub> = 4mA, V <sub>tL</sub> MAX, I <sub>tot</sub> = 8mA		0.25	0.4		0.25	0.4	V	
I <sub>I</sub> Input current at maximum input voltage	A/B or G			0.2			0.2	mA	
	A or B	V <sub>ee</sub> MAX, V <sub>I</sub> = 7V				0.1		0.1	mA
I <sub>tH</sub> High-level input current	A/B or G			40			40	µA	
	A or B	V <sub>ee</sub> MAX, V <sub>I</sub> = 2.1V				20		20	µA
I <sub>tL</sub> Low-level input current	A/B or G			-0.8			-0.8	mA	
	A or B	V <sub>ee</sub> = MAX, V <sub>I</sub> = 0.4V				-0.4		-0.4	mA
I <sub>OS</sub> Short-circuit output current <sup>§</sup>	V <sub>ee</sub> MAX	-20		-100		-20		mA	
I <sub>see</sub> Supply current <sup>  </sup>	V <sub>ee</sub> MAX, See Note		'LS157	9.7	16		9.7	16	mA
			'S158	4.8	8		4.8	8	mA
	V <sub>ee</sub> MAX, All A inputs at 4.5V, All other inputs at 0V		'S158	6.5	11		6.5	11	mA

<sup>1</sup> For conditions 1 to 5, see Note 1. MIN or MAX. Values are appropriate for the specified operating conditions.  
<sup>2</sup> All typical values are at V<sub>CC</sub> = 5V, T<sub>A</sub> = 25°C.  
<sup>§</sup> Not more than one output should be shorted at a time and duration of short circuit should not exceed 100µs.  
<sup>||</sup> NOTT = ICC time with V<sub>I</sub> = 4.5V applied to all inputs and all outputs open.

switching characteristics, V<sub>ee</sub> = 5V, T<sub>A</sub> = 25°C

PARAMETER	FROM (INPUT)	TEST CONDITIONS	'LS157			'LS156			UNIT
			MIN	TYP	MAX	MIN	TYP	MAX	
t <sub>PLH</sub>	Data	CL 15pF, RL = 2kΩ, See Note 3		9	14		7	12	ns
t <sub>PHL</sub>				9	14		10	15	
t <sub>PLH</sub>	Strobe G			13	20		11	17	ns
t <sub>PHL</sub>				14	21		18	24	
t <sub>PIH</sub>	Select A/B			15	23		13		ns
t <sub>PHL</sub>				18	27		16	2	

t<sub>PLH</sub> = propagation delay time, low-to-high-level output

t<sub>PHL</sub> = propagation delay time, high-to-low-level output

NOTE 3: Load circuit and voltage diagrams are shown in Section 1

**TEXAS.**  
**INSTRUMENTS**

POST OFFICE BOX 655011 • DALLAS, TEXAS 75215

# SN54S157, SN54S158, SN74S157, SN74S158 QUADRUPLE 2-LINE TO 1-LINE DATA SELECTORS/MULTIPLEXERS

recommended operating conditions

	SN54S157			SN74S157			UNIT
	MIN	NOM	MAX	MIN	NOM	MAX	
Supply voltage $V_{EE}$	4.5	5	5.5	4.75	5	5.25	V
High-level output current $I_{QH}$			-1			-1	mA
Low-level output current $I_{OL}$			20			20	mA
Operating free-air temperature, $T_A$	-55		125	0		70	C

electrical characteristics over recommended operating free-air temperature range (unless otherwise noted)

PARAMETER	TEST CONDITIONS <sup>t</sup>	SN54S157		SN74S158		UNIT		
		MIN	TYP <sup>†</sup>	MAX	MIN		TYP	MAX
$V_{IH}$ High-level input voltage		2			2	V		
$V_{IL}$ Low-level input voltage				0.8		0.8	V	
$V_{IK}$ Input clamp voltage	$V_{EE} \text{ MIN. } I_{t} = -18 \text{ mA}$			-1.2		-1.2	V	
$V_{OH}$ High-level output voltage	$V_{EE} = \text{MIN. } V_{IH} = 2 \text{ V, } I_{S} = 1 \text{ S}$	2.5	3.4	2.5	3.4	V		
	$V_{tL} = 0.8 \text{ V, } I_{OH} = -1 \text{ mA } I_{S} < 74 \text{ S}$	2.7	3.4	2.7	3.4			
$V_{OL}$ Low-level output voltage	$V_{EE} \text{ MIN. } V_{tH} = 2 \text{ V, } V_{tL} = 0.8 \text{ V, } I_{OL} = 20 \text{ mA}$			0.5		0.5	V	
$I_{I}$ Input current at maximum input voltage	$V_{EE} = \text{MAX. } V_{t} = .5 \text{ V}$			1		1	mA	
$I_{tH}$ High-level input current	A or B			100		100	A	
	A or B			50		50		
$I_{tL}$ Low-level input current	A or B			-4		-4	mA	
	A or B			-2		2		
$I_{OS}$ Short-circuit output current	$V_{EE} = \text{MAX}$	40		100		-10	-100	mA
	$V_{EE} = \text{MAX. All inputs } 1.4 \text{ V.}$			50	78	39	61	
$I_{EE}$ Supply current	See Note 2 $V_{EE} = \text{MAX, A inputs at } 4.5 \text{ V.}$						81	mA

B, G, S, input < at 0 V. See Note 2

<sup>t</sup>For conditions, see MIN or MAX, use the appropriate pin connections.

<sup>†</sup>Typical values are at  $V_{CC} = 5 \text{ V, } T_A = 25^\circ \text{C}$ .

Note: More than one output should be shorted at a time, and duration of the short circuit should not exceed one second.

Note 2:  $I_{CC}$  is measured with all outputs open.

switching characteristics,  $V_{EE} = 5 \text{ V, } T_A = 25^\circ \text{C}$

PARAMETER	FROM (INPUT)	TEST CONDITIONS	SN54S157		SN74S158		UNIT
			MIN	TYP	MAX	MIN	
$t_{PLH}$	Data	CL = 151-pf, RL = 2B011, See Note 3	5	7.5	4	6	ns
$t_{PHL}$	Data		4.5	6.5	4	6	
$t_{PLH}$	Strobe G		8.5	12.5	6.5	11.5	ns
$t_{PHL}$	Strobe G		7.5	12	7	12	
$t_{f>LH}$	Select A/B		9.5	15	8	12	ns
$t_{f>HL}$	Select A/B		9.5	15	8	12	

$t_{PLH}$  - propagation delay time, low-to-high-level output

$t_{PHL}$  - propagation delay time, high-to-low-level output

NOTE 3: Load circuits and voltage waveforms are shown in Section

Text...:-  
INSTR...:¥1£1'-iTS

PACKAGING INFORMATION

Orderable Device	Status <sup>(1)</sup>	Package Type	Package Drawing	Pins	Package Qty	Eco Plan <sup>(2)</sup>	Lead/Ball Finish	MSL Peak Temp <sup>(3)</sup>
76002012A	ACTIVE	LCCC	FK	20	1	TBD	POST-PLATE	N / A for Pkg Type
7600201EA	ACTIVE	CDIP	J	16	1	TBD	A42 SNPB	N / A for Pkg Type
7600201EA	ACTIVE	CDIP	J	16	1	TBD	A42 SNPB	N / A for Pkg Type
7600201FA	ACTIVE	CFP	W	16	1	TBD	A42	N / A for Pkg Type
7600201FA	ACTIVE	CFP	W	16	1	TBD	A42	N / A for Pkg Type
76033012A	ACTIVE	LCCC	FK	20	1	TBD	POST-PLATE	N / A for Pkg Type
76033012A	ACTIVE	LCCC	FK	20	1	TBD	POST-PLATE	N / A for Pkg Type
7603301EA	ACTIVE	CDIP	J	16	1	TBD	A42 SNPB	N / A for Pkg Type
7603301EA	ACTIVE	CDIP	J	16	1	TBD	A42 SNPB	N / A for Pkg Type
7603301FA	ACTIVE	CFP	W	16	1	TBD	A42	N / A for Pkg Type
7603301FA	ACTIVE	CFP	W	16	1	TBD	A42	N / A for Pkg Type
JM38510/07903BEA	ACTIVE	CDIP	J	16	1	TBD	A42 SNPB	N / A for Pkg Type
JM38510/07903BEA	ACTIVE	CDIP	J	16	1	TBD	A42 SNPB	N / A for Pkg Type
JM38510/07903BFA	ACTIVE	CFP	W	16	1	TBD	A42	N / A for Pkg Type
JM38510/07903BFA	ACTIVE	CFP	W	16	1	TBD	A42	N / A for Pkg Type
JM38510/07904BEA	OBSOLETE	CDIP	J	16		TBD	Call TI	Call TI
JM38510/07904BFA	OBSOLETE	CFP	W	16		TBD	Call TI	Call TI
JM38510/30903B2A	ACTIVE	LCCC	FK	20	1	TBD	POST-PLATE	N / A for Pkg Type
JM38510/30903B2A	ACTIVE	LCCC	FK	20	1	TBD	POST-PLATE	N / A for Pkg Type
JM38510/30903BEA	ACTIVE	CDIP	J	16	1	TBD	A42 SNPB	N / A for Pkg Type
JM38510/30903BEA	ACTIVE	CDIP	J	16	1	TBD	A42 SNPB	N / A for Pkg Type
JM38510/30903BFA	ACTIVE	CFP	W	16	1	TBD	A42	N / A for Pkg Type
JM38510/30903BFA	ACTIVE	CFP	W	16	1	TBD	A42	N / A for Pkg Type
SN54157J	ACTIVE	CDIP	J	16	1	TBD	A42 SNPB	N / A for Pkg Type
SN54157J	ACTIVE	CDIP	J	16	1	TBD	A42 SNPB	N / A for Pkg Type
SN54LS157J	ACTIVE	CDIP	J	16	1	TBD	A42 SNPB	N / A for Pkg Type
SN54LS157J	ACTIVE	CDIP	J	16	1	TBD	A42 SNPB	N / A for Pkg Type
SN54LS158J	ACTIVE	CDIP	J	16	1	TBD	A42 SNPB	N / A for Pkg Type
SN54LS158J	ACTIVE	CDIP	J	16	1	TBD	A42 SNPB	N / A for Pkg Type
SN54S157J	ACTIVE	CDIP	J	16	1	TBD	A42 SNPB	N / A for Pkg Type
SN54S157J	ACTIVE	CDIP	J	16	1	TBD	A42 SNPB	N / A for Pkg Type
SN54S158J	OBSOLETE	CDIP	J	16		TBD	Call TI	Call TI
SN54S15J	OBSOLETE	CDIP	J	14		TBD	Call TI	Call TI
SN74157N	OBSOLETE	PDIP	N	16		TBD	Call TI	Call TI
SN74157N	OBSOLETE	PDIP	N	16		TBD	Call TI	Call TI
SN74157N3	OBSOLETE	PDIP	N	16		TBD	Call TI	Call TI
SN74157N3	OBSOLETE	PDIP	N	16		TBD	Call TI	Call TI
SN74LS157D	ACTIVE	SOIC	D	16	40	Green (RoHS & no Sb/Br)	CU NIPDAU	Level-1-260C-UNLIM
SN74LS157D	ACTIVE	SOIC	D	16	40	Green (RoHS & no Sb/Br)	CU NIPDAU	Level-1-260C-UNLIM
SN74LS157DE4	ACTIVE	SOIC	D	16	40	Green (RoHS & no Sb/Br)	CU NIPDAU	Level-1-260C-UNLIM

Orderable Device	Status <sup>(1)</sup>	Package Type	Package Drawing	Pins	Package Qty	Eco Plan <sup>(2)</sup>	Lead/Ball Finish	MSL Peak Temp <sup>(3)</sup>
SN74LS157DE4	ACTIVE	SOIC	D	16	40	Green (RoHS & no Sb/Br)	CU NIPDAU	Level-1-260C-UNLIM
SN74LS157DG4	ACTIVE	SOIC	D	16	40	Green (RoHS & no Sb/Br)	CU NIPDAU	Level-1-260C-UNLIM
SN74LS157DG4	ACTIVE	SOIC	D	16	40	Green (RoHS & no Sb/Br)	CU NIPDAU	Level-1-260C-UNLIM
SN74LS157DR	ACTIVE	SOIC	D	16	2500	Green (RoHS & no Sb/Br)	CU NIPDAU	Level-1-260C-UNLIM
SN74LS157DR	ACTIVE	SOIC	D	16	2500	Green (RoHS & no Sb/Br)	CU NIPDAU	Level-1-260C-UNLIM
SN74LS157DRE4	ACTIVE	SOIC	D	16	2500	Green (RoHS & no Sb/Br)	CU NIPDAU	Level-1-260C-UNLIM
SN74LS157DRE4	ACTIVE	SOIC	D	16	2500	Green (RoHS & no Sb/Br)	CU NIPDAU	Level-1-260C-UNLIM
SN74LS157DRG4	ACTIVE	SOIC	D	16	2500	Green (RoHS & no Sb/Br)	CU NIPDAU	Level-1-260C-UNLIM
SN74LS157DRG4	ACTIVE	SOIC	D	16	2500	Green (RoHS & no Sb/Br)	CU NIPDAU	Level-1-260C-UNLIM
SN74LS157N	ACTIVE	PDIP	N	16	25	Pb-Free (RoHS)	CU NIPDAU	N / A for Pkg Type
SN74LS157N	ACTIVE	PDIP	N	16	25	Pb-Free (RoHS)	CU NIPDAU	N / A for Pkg Type
SN74LS157N3	OBSOLETE	PDIP	N	16		TBD	Call TI	Call TI
SN74LS157N3	OBSOLETE	PDIP	N	16		TBD	Call TI	Call TI
SN74LS157NE4	ACTIVE	PDIP	N	16	25	Pb-Free (RoHS)	CU NIPDAU	N / A for Pkg Type
SN74LS157NE4	ACTIVE	PDIP	N	16	25	Pb-Free (RoHS)	CU NIPDAU	N / A for Pkg Type
SN74LS157NSR	ACTIVE	SO	NS	16	2000	Green (RoHS & no Sb/Br)	CU NIPDAU	Level-1-260C-UNLIM
SN74LS157NSR	ACTIVE	SO	NS	16	2000	Green (RoHS & no Sb/Br)	CU NIPDAU	Level-1-260C-UNLIM
SN74LS157NSRE4	ACTIVE	SO	NS	16	2000	Green (RoHS & no Sb/Br)	CU NIPDAU	Level-1-260C-UNLIM
SN74LS157NSRE4	ACTIVE	SO	NS	16	2000	Green (RoHS & no Sb/Br)	CU NIPDAU	Level-1-260C-UNLIM
SN74LS157NSRG4	ACTIVE	SO	NS	16	2000	Green (RoHS & no Sb/Br)	CU NIPDAU	Level-1-260C-UNLIM
SN74LS157NSRG4	ACTIVE	SO	NS	16	2000	Green (RoHS & no Sb/Br)	CU NIPDAU	Level-1-260C-UNLIM
SN74LS158D	ACTIVE	SOIC	D	16	40	Green (RoHS & no Sb/Br)	CU NIPDAU	Level-1-260C-UNLIM
SN74LS158D	ACTIVE	SOIC	D	16	40	Green (RoHS & no Sb/Br)	CU NIPDAU	Level-1-260C-UNLIM
SN74LS158DE4	ACTIVE	SOIC	D	16	40	Green (RoHS & no Sb/Br)	CU NIPDAU	Level-1-260C-UNLIM
SN74LS158DE4	ACTIVE	SOIC	D	16	40	Green (RoHS & no Sb/Br)	CU NIPDAU	Level-1-260C-UNLIM
SN74LS158DG4	ACTIVE	SOIC	D	16	40	Green (RoHS & no Sb/Br)	CU NIPDAU	Level-1-260C-UNLIM
SN74LS158DG4	ACTIVE	SOIC	D	16	40	Green (RoHS & no Sb/Br)	CU NIPDAU	Level-1-260C-UNLIM



Orderable Device	Status <sup>(1)</sup>	Package Type	Package Drawing	Pins	Package Qty	Eco Plan <sup>(2)</sup>	Lead/Ball Finish	MSL Peak Temp <sup>(3)</sup>
						no Sb/Br)		
SN74LS158DR	ACTIVE	SOIC	D	16	2500	Green (RoHS & no Sb/Br)	CU NIPDAU	Level-1-260C-UNLIM
SN74LS158DR	ACTIVE	SOIC	D	16	2500	Green (RoHS & no Sb/Br)	CU NIPDAU	Level-1-260C-UNLIM
SN74LS158DRE4	ACTIVE	SOIC	D	16	2500	Green (RoHS & no Sb/Br)	CU NIPDAU	Level-1-260C-UNLIM
SN74LS158DRE4	ACTIVE	SOIC	D	16	2500	Green (RoHS & no Sb/Br)	CU NIPDAU	Level-1-260C-UNLIM
SN74LS158DRG4	ACTIVE	SOIC	D	16	2500	Green (RoHS & no Sb/Br)	CU NIPDAU	Level-1-260C-UNLIM
SN74LS158DRG4	ACTIVE	SOIC	D	16	2500	Green (RoHS & no Sb/Br)	CU NIPDAU	Level-1-260C-UNLIM
SN74LS158N	ACTIVE	PDIP	N	16	25	Pb-Free (RoHS)	CU NIPDAU	N / A for Pkg Type
SN74LS158N	ACTIVE	PDIP	N	16	25	Pb-Free (RoHS)	CU NIPDAU	N / A for Pkg Type
SN74LS158N3	OBSOLETE	PDIP	N	16		TBD	Call TI	Call TI
SN74LS158N3	OBSOLETE	PDIP	N	16		TBD	Call TI	Call TI
SN74LS158NE4	ACTIVE	PDIP	N	16	25	Pb-Free (RoHS)	CU NIPDAU	N / A for Pkg Type
SN74LS158NE4	ACTIVE	PDIP	N	16	25	Pb-Free (RoHS)	CU NIPDAU	N / A for Pkg Type
SN74LS158NSR	ACTIVE	SO	NS	16	2000	Green (RoHS & no Sb/Br)	CU NIPDAU	Level-1-260C-UNLIM
SN74LS158NSR	ACTIVE	SO	NS	16	2000	Green (RoHS & no Sb/Br)	CU NIPDAU	Level-1-260C-UNLIM
SN74LS158NSRE4	ACTIVE	SO	NS	16	2000	Green (RoHS & no Sb/Br)	CU NIPDAU	Level-1-260C-UNLIM
SN74LS158NSRE4	ACTIVE	SO	NS	16	2000	Green (RoHS & no Sb/Br)	CU NIPDAU	Level-1-260C-UNLIM
SN74LS158NSRG4	ACTIVE	SO	NS	16	2000	Green (RoHS & no Sb/Br)	CU NIPDAU	Level-1-260C-UNLIM
SN74LS158NSRG4	ACTIVE	SO	NS	16	2000	Green (RoHS & no Sb/Br)	CU NIPDAU	Level-1-260C-UNLIM
SN74S157D	ACTIVE	SOIC	D	16	40	Green (RoHS & no Sb/Br)	CU NIPDAU	Level-1-260C-UNLIM
SN74S157DE4	ACTIVE	SOIC	D	16	40	Green (RoHS & no Sb/Br)	CU NIPDAU	Level-1-260C-UNLIM
SN74S157DG4	ACTIVE	SOIC	D	16	40	Green (RoHS & no Sb/Br)	CU NIPDAU	Level-1-260C-UNLIM
SN74S157N	ACTIVE	PDIP	N	16	25	Pb-Free (RoHS)	CU NIPDAU	N / A for Pkg Type
SN74S157N3	OBSOLETE	PDIP	N	16		TBD	Call TI	Call TI
SN74S157NE4	ACTIVE	PDIP	N	16	25	Pb-Free (RoHS)	CU NIPDAU	N / A for Pkg Type
SN74S157NSR	ACTIVE	SO	NS	16	2000	Green (RoHS & no Sb/Br)	CU NIPDAU	Level-1-260C-UNLIM
SN74S157NSRE4	ACTIVE	SO	NS	16	2000	Green (RoHS & no Sb/Br)	CU NIPDAU	Level-1-260C-UNLIM
SN74S157NSRG4	ACTIVE	SO	NS	16	2000	Green (RoHS & no Sb/Br)	CU NIPDAU	Level-1-260C-UNLIM

Orderable Device	Status <sup>(1)</sup>	Package Type	Package Drawing	Pins	Package Qty	Eco Plan <sup>(2)</sup>	Lead/Ball Finish	MSL Peak Temp <sup>(3)</sup>
no Sb/Br)								
SN74S158D	OBSOLETE	SOIC	D	16		TBD	Call TI	Call TI
SN74S158D	OBSOLETE	SOIC	D	16		TBD	Call TI	Call TI
SN74S158DR	OBSOLETE	SOIC	D	16		TBD	Call TI	Call TI
SN74S158DR	OBSOLETE	SOIC	D	16		TBD	Call TI	Call TI
SN74S158N	OBSOLETE	PDIP	N	16		TBD	Call TI	Call TI
SN74S158N	OBSOLETE	PDIP	N	16		TBD	Call TI	Call TI
SN74S158N3	OBSOLETE	PDIP	N	16		TBD	Call TI	Call TI
SN74S158N3	OBSOLETE	PDIP	N	16		TBD	Call TI	Call TI
SNJ54157J	ACTIVE	CDIP	J	16	1	TBD	A42 SNPB	N / A for Pkg Type
SNJ54157J	ACTIVE	CDIP	J	16	1	TBD	A42 SNPB	N / A for Pkg Type
SNJ54157W	ACTIVE	CFP	W	16	1	TBD	A42	N / A for Pkg Type
SNJ54157W	ACTIVE	CFP	W	16	1	TBD	A42	N / A for Pkg Type
SNJ54LS157FK	ACTIVE	LCCC	FK	20	1	TBD	POST-PLATE	N / A for Pkg Type
SNJ54LS157FK	ACTIVE	LCCC	FK	20	1	TBD	POST-PLATE	N / A for Pkg Type
SNJ54LS157J	ACTIVE	CDIP	J	16	1	TBD	A42 SNPB	N / A for Pkg Type
SNJ54LS157J	ACTIVE	CDIP	J	16	1	TBD	A42 SNPB	N / A for Pkg Type
SNJ54LS157W	ACTIVE	CFP	W	16	1	TBD	A42	N / A for Pkg Type
SNJ54LS157W	ACTIVE	CFP	W	16	1	TBD	A42	N / A for Pkg Type
SNJ54LS158FK	ACTIVE	LCCC	FK	20	1	TBD	POST-PLATE	N / A for Pkg Type
SNJ54LS158FK	ACTIVE	LCCC	FK	20	1	TBD	POST-PLATE	N / A for Pkg Type
SNJ54LS158J	ACTIVE	CDIP	J	16	1	TBD	A42 SNPB	N / A for Pkg Type
SNJ54LS158J	ACTIVE	CDIP	J	16	1	TBD	A42 SNPB	N / A for Pkg Type
SNJ54LS158W	ACTIVE	CFP	W	16	1	TBD	A42	N / A for Pkg Type
SNJ54LS158W	ACTIVE	CFP	W	16	1	TBD	A42	N / A for Pkg Type
SNJ54S157FK	ACTIVE	LCCC	FK	20	1	TBD	POST-PLATE	N / A for Pkg Type
SNJ54S157FK	ACTIVE	LCCC	FK	20	1	TBD	POST-PLATE	N / A for Pkg Type
SNJ54S157J	ACTIVE	CDIP	J	16	1	TBD	A42 SNPB	N / A for Pkg Type
SNJ54S157J	ACTIVE	CDIP	J	16	1	TBD	A42 SNPB	N / A for Pkg Type
SNJ54S157W	ACTIVE	CFP	W	16	1	TBD	A42	N / A for Pkg Type
SNJ54S157W	ACTIVE	CFP	W	16	1	TBD	A42	N / A for Pkg Type
SNJ54S158FK	OBSOLETE	LCCC	FK	20		TBD	Call TI	Call TI
SNJ54S158J	OBSOLETE	CDIP	J	16		TBD	Call TI	Call TI
SNJ54S158W	OBSOLETE	CFP	W	16		TBD	Call TI	Call TI
SNJ54S15FK	OBSOLETE	LCCC	FK	20		TBD	Call TI	Call TI
SNJ54S15J	OBSOLETE	CDIP	J	14		TBD	Call TI	Call TI
SNJ54S15W	OBSOLETE	CFP	W	14		TBD	Call TI	Call TI

<sup>(1)</sup> The marketing status values are defined as follows:

**ACTIVE:** Product device recommended for new designs.

**LIFEBUY:** TI has announced that the device will be discontinued, and a lifetime-buy period is in effect.

**NRND:** Not recommended for new designs. Device is in production to support existing customers, but TI does not recommend using this part in a new design.

**PREVIEW:** Device has been announced but is not in production. Samples may or may not be available.

**OBSOLETE:** TI has discontinued the production of the device.

---

<sup>(2)</sup> Eco Plan - The planned eco-friendly classification: Pb-Free (RoHS), Pb-Free (RoHS Exempt), or Green (RoHS & no Sb/Br) - please check <http://www.ti.com/productcontent> for the latest availability information and additional product content details.

**TBD:** The Pb-Free/Green conversion plan has not been defined.

**Pb-Free (RoHS):** TI's terms "Lead-Free" or "Pb-Free" mean semiconductor products that are compatible with the current RoHS requirements for all 6 substances, including the requirement that lead not exceed 0.1% by weight in homogeneous materials. Where designed to be soldered at high temperatures, TI Pb-Free products are suitable for use in specified lead-free processes.

**Pb-Free (RoHS Exempt):** This component has a RoHS exemption for either 1) lead-based flip-chip solder bumps used between the die and package, or 2) lead-based die adhesive used between the die and leadframe. The component is otherwise considered Pb-Free (RoHS compatible) as defined above.

**Green (RoHS & no Sb/Br):** TI defines "Green" to mean Pb-Free (RoHS compatible), and free of Bromine (Br) and Antimony (Sb) based flame retardants (Br or Sb do not exceed 0.1% by weight in homogeneous material)

<sup>(3)</sup> MSL, Peak Temp. -- The Moisture Sensitivity Level rating according to the JEDEC industry standard classifications, and peak solder temperature.

**Important Information and Disclaimer:**The information provided on this page represents TI's knowledge and belief as of the date that it is provided. TI bases its knowledge and belief on information provided by third parties, and makes no representation or warranty as to the accuracy of such information. Efforts are underway to better integrate information from third parties. TI has taken and continues to take reasonable steps to provide representative and accurate information but may not have conducted destructive testing or chemical analysis on incoming materials and chemicals. TI and TI suppliers consider certain information to be proprietary, and thus CAS numbers and other limited information may not be available for release.

In no event shall TI's liability arising out of such information exceed the total purchase price of the TI part(s) at issue in this document sold by TI to Customer on an annual basis.



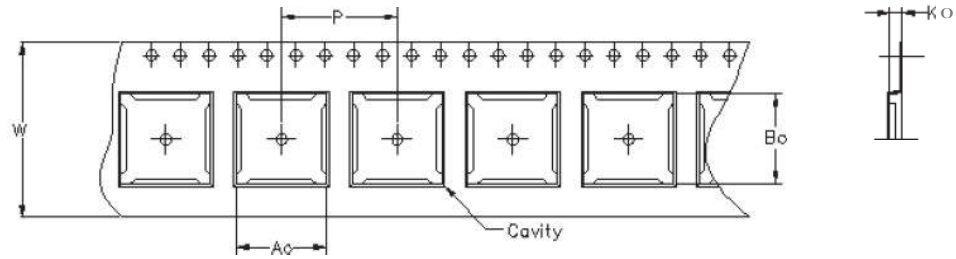

Carrier tape design is defined largely by the component length, width, and thickness.

$A_o$ = Dimension designed to accommodate the component width.
$B_o$ = Dimension designed to accommodate the component length.
$K_o$ = Dimension designed to accommodate the component thickness.
$W$ = Overall width of the carrier tape.
$P$ = Pitch between successive cavity centers.

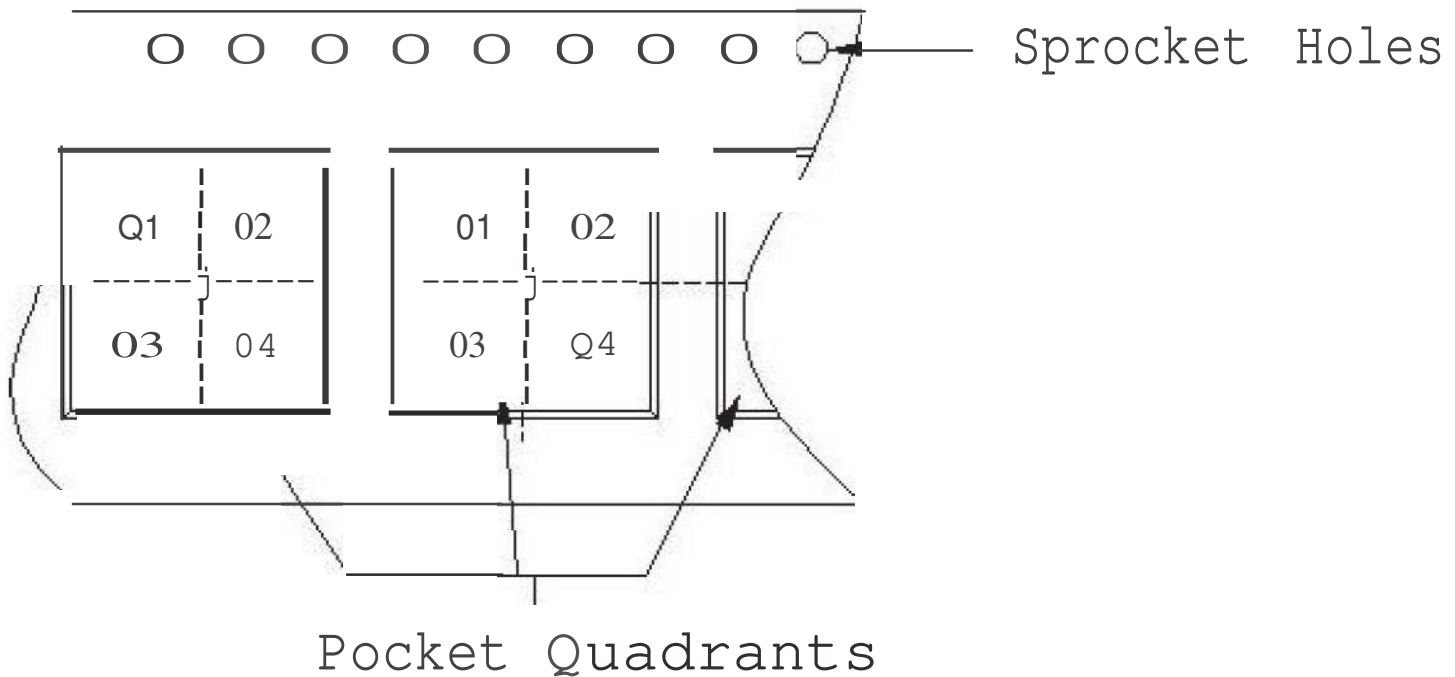

**TAPE AND REEL INFORMATION**

Device	Package	Pins	Site	Reel Diameter (mm)	Reel Width (mm)	A0 (mm)	B0 (mm)	K0 (mm)	P1 (mm)	W (mm)	Pin1 Quadrant
SN74LS157DR	D	16	FMX	330	16	6.5	10.3	2.1	8	16	Q1
SN74LS157NSR	NS	16	MLA	330	16	8.2	10.5	2.5	12	16	Q1
SN74LS158DR	D	16	FMX	330	16	6.5	10.3	2.1	8	16	Q1
SN74LS158NSR	NS	16	MLA	330	16	8.2	10.5	2.5	12	16	Q1
SN74S157NSR	NS	16	MLA	330	16	8.2	10.5	2.5	12	16	Q1

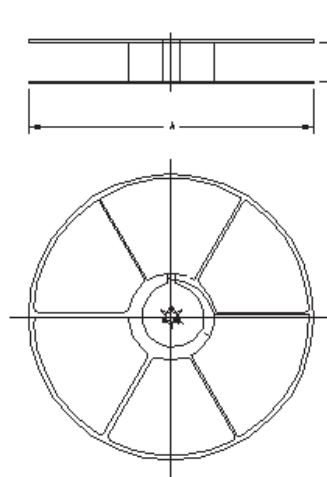

**TAPE AND REEL BOX INFORMATION**

Device	Package	Pins	Site	Length (mm)	Width (mm)	Height (mm)
SN74LS157DR	D	16	FMX	342.9	336.6	28.58
SN74LS157NSR	NS	16	MLA	342.9	336.6	28.58
SN74LS158DR	D	16	FMX	342.9	336.6	28.58
SN74LS158NSR	NS	16	MLA	342.9	336.6	28.58
SN74S157NSR	NS	16	MLA	342.9	336.6	28.58

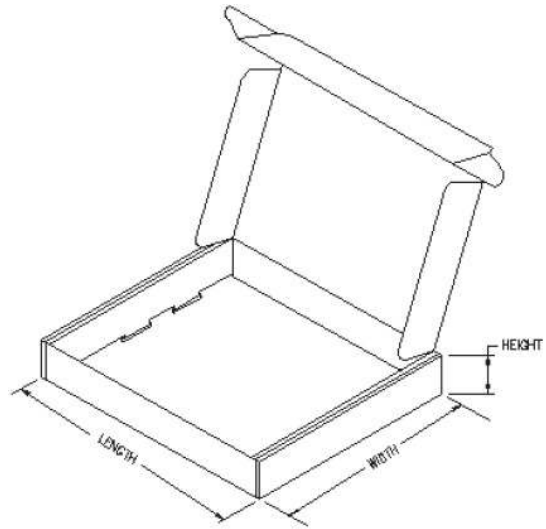





PACKAGING INFORMATION

Orderable Device	Status <sup>(1)</sup>	Package Type	Package Drawing	Pins	Package Qty	Eco Plan <sup>(2)</sup>	Lead/Ball Finish	MSL Peak Temp <sup>(3)</sup>
76002012A	ACTIVE	LCCC	FK	20	1	TBD	POST-PLATE	N / A for Pkg Type
76002012A	ACTIVE	LCCC	FK	20	1	TBD	POST-PLATE	N / A for Pkg Type
7600201EA	ACTIVE	CDIP	J	16	1	TBD	A42 SNPB	N / A for Pkg Type
7600201EA	ACTIVE	CDIP	J	16	1	TBD	A42 SNPB	N / A for Pkg Type
7600201FA	ACTIVE	CFP	W	16	1	TBD	A42	N / A for Pkg Type
7600201FA	ACTIVE	CFP	W	16	1	TBD	A42	N / A for Pkg Type
76033012A	ACTIVE	LCCC	FK	20	1	TBD	POST-PLATE	N / A for Pkg Type
76033012A	ACTIVE	LCCC	FK	20	1	TBD	POST-PLATE	N / A for Pkg Type
7603301EA	ACTIVE	CDIP	J	16	1	TBD	A42 SNPB	N / A for Pkg Type
7603301EA	ACTIVE	CDIP	J	16	1	TBD	A42 SNPB	N / A for Pkg Type
7603301FA	ACTIVE	CFP	W	16	1	TBD	A42	N / A for Pkg Type
7603301FA	ACTIVE	CFP	W	16	1	TBD	A42	N / A for Pkg Type
JM38510/07903BEA	ACTIVE	CDIP	J	16	1	TBD	A42 SNPB	N / A for Pkg Type
JM38510/07903BEA	ACTIVE	CDIP	J	16	1	TBD	A42 SNPB	N / A for Pkg Type
JM38510/07903BFA	ACTIVE	CFP	W	16	1	TBD	A42	N / A for Pkg Type
JM38510/07903BFA	ACTIVE	CFP	W	16	1	TBD	A42	N / A for Pkg Type
JM38510/07904BEA	OBSOLETE	CDIP	J	16		TBD	Call TI	Call TI
JM38510/07904BFA	OBSOLETE	CFP	W	16		TBD	Call TI	Call TI
JM38510/30903B2A	ACTIVE	LCCC	FK	20	1	TBD	POST-PLATE	N / A for Pkg Type
JM38510/30903B2A	ACTIVE	LCCC	FK	20	1	TBD	POST-PLATE	N / A for Pkg Type
JM38510/30903BEA	ACTIVE	CDIP	J	16	1	TBD	A42 SNPB	N / A for Pkg Type
JM38510/30903BEA	ACTIVE	CDIP	J	16	1	TBD	A42 SNPB	N / A for Pkg Type
JM38510/30903BFA	ACTIVE	CFP	W	16	1	TBD	A42	N / A for Pkg Type
JM38510/30903BFA	ACTIVE	CFP	W	16	1	TBD	A42	N / A for Pkg Type
SN54157J	ACTIVE	CDIP	J	16	1	TBD	A42 SNPB	N / A for Pkg Type
SN54157J	ACTIVE	CDIP	J	16	1	TBD	A42 SNPB	N / A for Pkg Type
SN54LS157J	ACTIVE	CDIP	J	16	1	TBD	A42 SNPB	N / A for Pkg Type
SN54LS157J	ACTIVE	CDIP	J	16	1	TBD	A42 SNPB	N / A for Pkg Type
SN54LS158J	ACTIVE	CDIP	J	16	1	TBD	A42 SNPB	N / A for Pkg Type
SN54LS158J	ACTIVE	CDIP	J	16	1	TBD	A42 SNPB	N / A for Pkg Type
SN54S157J	ACTIVE	CDIP	J	16	1	TBD	A42 SNPB	N / A for Pkg Type
SN54S157J	ACTIVE	CDIP	J	16	1	TBD	A42 SNPB	N / A for Pkg Type
SN54S158J	OBSOLETE	CDIP	J	16		TBD	Call TI	Call TI
SN54S15J	OBSOLETE	CDIP	J	14		TBD	Call TI	Call TI
SN74157N	OBSOLETE	PDIP	N	16		TBD	Call TI	Call TI
SN74157N	OBSOLETE	PDIP	N	16		TBD	Call TI	Call TI
SN74157N3	OBSOLETE	PDIP	N	16		TBD	Call TI	Call TI
SN74157N3	OBSOLETE	PDIP	N	16		TBD	Call TI	Call TI
SN74LS157D	ACTIVE	SOIC	D	16	40	Green (RoHS & no Sb/Br)	CU NIPDAU	Level-1-260C-UNLIM
SN74LS157D	ACTIVE	SOIC	D	16	40	Green (RoHS & no Sb/Br)	CU NIPDAU	Level-1-260C-UNLIM

Orderable Device	Status <sup>(1)</sup>	Package Type	Package Drawing	Pins	Package Qty	Eco Plan <sup>(2)</sup>	Lead/Ball Finish	MSL Peak Temp <sup>(3)</sup>
SN74LS157DE4	ACTIVE	SOIC	D	16	40	Green (RoHS & no Sb/Br)	CU NIPDAU	Level-1-260C-UNLIM
SN74LS157DE4	ACTIVE	SOIC	D	16	40	Green (RoHS & no Sb/Br)	CU NIPDAU	Level-1-260C-UNLIM
SN74LS157DG4	ACTIVE	SOIC	D	16	40	Green (RoHS & no Sb/Br)	CU NIPDAU	Level-1-260C-UNLIM
SN74LS157DG4	ACTIVE	SOIC	D	16	40	Green (RoHS & no Sb/Br)	CU NIPDAU	Level-1-260C-UNLIM
SN74LS157DR	ACTIVE	SOIC	D	16	2500	Green (RoHS & no Sb/Br)	CU NIPDAU	Level-1-260C-UNLIM
SN74LS157DR	ACTIVE	SOIC	D	16	2500	Green (RoHS & no Sb/Br)	CU NIPDAU	Level-1-260C-UNLIM
SN74LS157DRE4	ACTIVE	SOIC	D	16	2500	Green (RoHS & no Sb/Br)	CU NIPDAU	Level-1-260C-UNLIM
SN74LS157DRE4	ACTIVE	SOIC	D	16	2500	Green (RoHS & no Sb/Br)	CU NIPDAU	Level-1-260C-UNLIM
SN74LS157DRG4	ACTIVE	SOIC	D	16	2500	Green (RoHS & no Sb/Br)	CU NIPDAU	Level-1-260C-UNLIM
SN74LS157DRG4	ACTIVE	SOIC	D	16	2500	Green (RoHS & no Sb/Br)	CU NIPDAU	Level-1-260C-UNLIM
SN74LS157N	ACTIVE	PDIP	N	16	25	Pb-Free (RoHS)	CU NIPDAU	N / A for Pkg Type
SN74LS157N	ACTIVE	PDIP	N	16	25	Pb-Free (RoHS)	CU NIPDAU	N / A for Pkg Type
SN74LS157N3	OBSOLETE	PDIP	N	16		TBD	Call TI	Call TI
SN74LS157N3	OBSOLETE	PDIP	N	16		TBD	Call TI	Call TI
SN74LS157NE4	ACTIVE	PDIP	N	16	25	Pb-Free (RoHS)	CU NIPDAU	N / A for Pkg Type
SN74LS157NE4	ACTIVE	PDIP	N	16	25	Pb-Free (RoHS)	CU NIPDAU	N / A for Pkg Type
SN74LS157NSR	ACTIVE	SO	NS	16	2000	Green (RoHS & no Sb/Br)	CU NIPDAU	Level-1-260C-UNLIM
SN74LS157NSR	ACTIVE	SO	NS	16	2000	Green (RoHS & no Sb/Br)	CU NIPDAU	Level-1-260C-UNLIM
SN74LS157NSRE4	ACTIVE	SO	NS	16	2000	Green (RoHS & no Sb/Br)	CU NIPDAU	Level-1-260C-UNLIM
SN74LS157NSRE4	ACTIVE	SO	NS	16	2000	Green (RoHS & no Sb/Br)	CU NIPDAU	Level-1-260C-UNLIM
SN74LS157NSRG4	ACTIVE	SO	NS	16	2000	Green (RoHS & no Sb/Br)	CU NIPDAU	Level-1-260C-UNLIM
SN74LS157NSRG4	ACTIVE	SO	NS	16	2000	Green (RoHS & no Sb/Br)	CU NIPDAU	Level-1-260C-UNLIM
SN74LS158D	ACTIVE	SOIC	D	16	40	Green (RoHS & no Sb/Br)	CU NIPDAU	Level-1-260C-UNLIM
SN74LS158D	ACTIVE	SOIC	D	16	40	Green (RoHS & no Sb/Br)	CU NIPDAU	Level-1-260C-UNLIM
SN74LS158DE4	ACTIVE	SOIC	D	16	40	Green (RoHS & no Sb/Br)	CU NIPDAU	Level-1-260C-UNLIM
SN74LS158DE4	ACTIVE	SOIC	D	16	40	Green (RoHS & no Sb/Br)	CU NIPDAU	Level-1-260C-UNLIM
SN74LS158DG4	ACTIVE	SOIC	D	16	40	Green (RoHS & no Sb/Br)	CU NIPDAU	Level-1-260C-UNLIM

Orderable Device	Status <sup>(1)</sup>	Package Type	Package Drawing	Pins	Package Qty	Eco Plan <sup>(2)</sup>	Lead/Ball Finish	MSL Peak Temp <sup>(3)</sup>
						no Sb/Br)		
SN74LS158DG4	ACTIVE	SOIC	D	16	40	Green (RoHS & no Sb/Br)	CU NIPDAU	Level-1-260C-UNLIM
SN74LS158DR	ACTIVE	SOIC	D	16	2500	Green (RoHS & no Sb/Br)	CU NIPDAU	Level-1-260C-UNLIM
SN74LS158DR	ACTIVE	SOIC	D	16	2500	Green (RoHS & no Sb/Br)	CU NIPDAU	Level-1-260C-UNLIM
SN74LS158DRE4	ACTIVE	SOIC	D	16	2500	Green (RoHS & no Sb/Br)	CU NIPDAU	Level-1-260C-UNLIM
SN74LS158DRE4	ACTIVE	SOIC	D	16	2500	Green (RoHS & no Sb/Br)	CU NIPDAU	Level-1-260C-UNLIM
SN74LS158DRG4	ACTIVE	SOIC	D	16	2500	Green (RoHS & no Sb/Br)	CU NIPDAU	Level-1-260C-UNLIM
SN74LS158DRG4	ACTIVE	SOIC	D	16	2500	Green (RoHS & no Sb/Br)	CU NIPDAU	Level-1-260C-UNLIM
SN74LS158N	ACTIVE	PDIP	N	16	25	Pb-Free (RoHS)	CU NIPDAU	N / A for Pkg Type
SN74LS158N	ACTIVE	PDIP	N	16	25	Pb-Free (RoHS)	CU NIPDAU	N / A for Pkg Type
SN74LS158N3	OBSOLETE	PDIP	N	16		TBD	Call TI	Call TI
SN74LS158N3	OBSOLETE	PDIP	N	16		TBD	Call TI	Call TI
SN74LS158NE4	ACTIVE	PDIP	N	16	25	Pb-Free (RoHS)	CU NIPDAU	N / A for Pkg Type
SN74LS158NE4	ACTIVE	PDIP	N	16	25	Pb-Free (RoHS)	CU NIPDAU	N / A for Pkg Type
SN74LS158NSR	ACTIVE	SO	NS	16	2000	Green (RoHS & no Sb/Br)	CU NIPDAU	Level-1-260C-UNLIM
SN74LS158NSR	ACTIVE	SO	NS	16	2000	Green (RoHS & no Sb/Br)	CU NIPDAU	Level-1-260C-UNLIM
SN74LS158NSRE4	ACTIVE	SO	NS	16	2000	Green (RoHS & no Sb/Br)	CU NIPDAU	Level-1-260C-UNLIM
SN74LS158NSRE4	ACTIVE	SO	NS	16	2000	Green (RoHS & no Sb/Br)	CU NIPDAU	Level-1-260C-UNLIM
SN74LS158NSRG4	ACTIVE	SO	NS	16	2000	Green (RoHS & no Sb/Br)	CU NIPDAU	Level-1-260C-UNLIM
SN74LS158NSRG4	ACTIVE	SO	NS	16	2000	Green (RoHS & no Sb/Br)	CU NIPDAU	Level-1-260C-UNLIM
SN74S157D	ACTIVE	SOIC	D	16	40	Green (RoHS & no Sb/Br)	CU NIPDAU	Level-1-260C-UNLIM
SN74S157DE4	ACTIVE	SOIC	D	16	40	Green (RoHS & no Sb/Br)	CU NIPDAU	Level-1-260C-UNLIM
SN74S157DG4	ACTIVE	SOIC	D	16	40	Green (RoHS & no Sb/Br)	CU NIPDAU	Level-1-260C-UNLIM
SN74S157N	ACTIVE	PDIP	N	16	25	Pb-Free (RoHS)	CU NIPDAU	N / A for Pkg Type
SN74S157N3	OBSOLETE	PDIP	N	16		TBD	Call TI	Call TI
SN74S157NE4	ACTIVE	PDIP	N	16	25	Pb-Free (RoHS)	CU NIPDAU	N / A for Pkg Type
SN74S157NSR	ACTIVE	SO	NS	16	2000	Green (RoHS & no Sb/Br)	CU NIPDAU	Level-1-260C-UNLIM
SN74S157NSRE4	ACTIVE	SO	NS	16	2000	Green (RoHS & no Sb/Br)	CU NIPDAU	Level-1-260C-UNLIM

Orderable Device	Status <sup>(1)</sup>	Package Type	Package Drawing	Pins	Package Qty	Eco Plan <sup>(2)</sup>	Lead/Ball Finish	MSL Peak Temp <sup>(3)</sup>
						no Sb/Br)		
SN74S157NSRG4	ACTIVE	SO	NS	16	2000	Green (RoHS & no Sb/Br)	CU NIPDAU	Level-1-260C-UNLIM
SN74S158D	OBSOLETE	SOIC	D	16		TBD	Call TI	Call TI
SN74S158D	OBSOLETE	SOIC	D	16		TBD	Call TI	Call TI
SN74S158DR	OBSOLETE	SOIC	D	16		TBD	Call TI	Call TI
SN74S158DR	OBSOLETE	SOIC	D	16		TBD	Call TI	Call TI
SN74S158N	OBSOLETE	PDIP	N	16		TBD	Call TI	Call TI
SN74S158N	OBSOLETE	PDIP	N	16		TBD	Call TI	Call TI
SN74S158N3	OBSOLETE	PDIP	N	16		TBD	Call TI	Call TI
SN74S158N3	OBSOLETE	PDIP	N	16		TBD	Call TI	Call TI
SNJ54157J	ACTIVE	CDIP	J	16	1	TBD	A42 SNPB	N / A for Pkg Type
SNJ54157J	ACTIVE	CDIP	J	16	1	TBD	A42 SNPB	N / A for Pkg Type
SNJ54157W	ACTIVE	CFP	W	16	1	TBD	A42	N / A for Pkg Type
SNJ54157W	ACTIVE	CFP	W	16	1	TBD	A42	N / A for Pkg Type
SNJ54LS157FK	ACTIVE	LCCC	FK	20	1	TBD	POST-PLATE	N / A for Pkg Type
SNJ54LS157FK	ACTIVE	LCCC	FK	20	1	TBD	POST-PLATE	N / A for Pkg Type
SNJ54LS157J	ACTIVE	CDIP	J	16	1	TBD	A42 SNPB	N / A for Pkg Type
SNJ54LS157J	ACTIVE	CDIP	J	16	1	TBD	A42 SNPB	N / A for Pkg Type
SNJ54LS157W	ACTIVE	CFP	W	16	1	TBD	A42	N / A for Pkg Type
SNJ54LS157W	ACTIVE	CFP	W	16	1	TBD	A42	N / A for Pkg Type
SNJ54LS158FK	ACTIVE	LCCC	FK	20	1	TBD	POST-PLATE	N / A for Pkg Type
SNJ54LS158FK	ACTIVE	LCCC	FK	20	1	TBD	POST-PLATE	N / A for Pkg Type
SNJ54LS158J	ACTIVE	CDIP	J	16	1	TBD	A42 SNPB	N / A for Pkg Type
SNJ54LS158J	ACTIVE	CDIP	J	16	1	TBD	A42 SNPB	N / A for Pkg Type
SNJ54LS158W	ACTIVE	CFP	W	16	1	TBD	A42	N / A for Pkg Type
SNJ54LS158W	ACTIVE	CFP	W	16	1	TBD	A42	N / A for Pkg Type
SNJ54S157FK	ACTIVE	LCCC	FK	20	1	TBD	POST-PLATE	N / A for Pkg Type
SNJ54S157FK	ACTIVE	LCCC	FK	20	1	TBD	POST-PLATE	N / A for Pkg Type
SNJ54S157J	ACTIVE	CDIP	J	16	1	TBD	A42 SNPB	N / A for Pkg Type
SNJ54S157J	ACTIVE	CDIP	J	16	1	TBD	A42 SNPB	N / A for Pkg Type
SNJ54S157W	ACTIVE	CFP	W	16	1	TBD	A42	N / A for Pkg Type
SNJ54S157W	ACTIVE	CFP	W	16	1	TBD	A42	N / A for Pkg Type
SNJ54S158FK	OBSOLETE	LCCC	FK	20		TBD	Call TI	Call TI
SNJ54S158J	OBSOLETE	CDIP	J	16		TBD	Call TI	Call TI
SNJ54S158W	OBSOLETE	CFP	W	16		TBD	Call TI	Call TI
SNJ54S15FK	OBSOLETE	LCCC	FK	20		TBD	Call TI	Call TI
SNJ54S15J	OBSOLETE	CDIP	J	14		TBD	Call TI	Call TI
SNJ54S15W	OBSOLETE	CFP	W	14		TBD	Call TI	Call TI

<sup>(1)</sup> The marketing status values are defined as follows:

**ACTIVE:** Product device recommended for new designs.

**LIFEBUY:** TI has announced that the device will be discontinued, and a lifetime-buy period is in effect.

**NRND:** Not recommended for new designs. Device is in production to support existing customers, but TI does not recommend using this part in a new design.

**PREVIEW:** Device has been announced but is not in production. Samples may or may not be available.

---

**OBSOLETE:** TI has discontinued the production of the device.

<sup>(2)</sup> Eco Plan - The planned eco-friendly classification: Pb-Free (RoHS), Pb-Free (RoHS Exempt), or Green (RoHS & no Sb/Br) - please check <http://www.ti.com/productcontent> for the latest availability information and additional product content details.

**TBD:** The Pb-Free/Green conversion plan has not been defined.

**Pb-Free (RoHS):** TI's terms "Lead-Free" or "Pb-Free" mean semiconductor products that are compatible with the current RoHS requirements for all 6 substances, including the requirement that lead not exceed 0.1% by weight in homogeneous materials. Where designed to be soldered at high temperatures, TI Pb-Free products are suitable for use in specified lead-free processes.

**Pb-Free (RoHS Exempt):** This component has a RoHS exemption for either 1) lead-based flip-chip solder bumps used between the die and package, or 2) lead-based die adhesive used between the die and leadframe. The component is otherwise considered Pb-Free (RoHS compatible) as defined above.

**Green (RoHS & no Sb/Br):** TI defines "Green" to mean Pb-Free (RoHS compatible), and free of Bromine (Br) and Antimony (Sb) based flame retardants (Br or Sb do not exceed 0.1% by weight in homogeneous material)

<sup>(3)</sup> MSL, Peak Temp. -- The Moisture Sensitivity Level rating according to the JEDEC industry standard classifications, and peak solder temperature.

**Important Information and Disclaimer:**The information provided on this page represents TI's knowledge and belief as of the date that it is provided. TI bases its knowledge and belief on information provided by third parties, and makes no representation or warranty as to the accuracy of such information. Efforts are underway to better integrate information from third parties. TI has taken and continues to take reasonable steps to provide representative and accurate information but may not have conducted destructive testing or chemical analysis on incoming materials and chemicals. TI and TI suppliers consider certain information to be proprietary, and thus CAS numbers and other limited information may not be available for release.

In no event shall TI's liability arising out of such information exceed the total purchase price of the TI part(s) at issue in this document sold by TI to Customer on an annual basis.

**OTHER QUALIFIED VERSIONS OF SN54157, SN54LS157, SN54LS158, SN54S15, SN54S157, SN54S158, SN74157, SN74LS157, SN74LS158, SN74S157, SN74S158 :**

• Catalog: [SN74S15](#)

NOTE: Qualified Version Definitions:

• Catalog - TI's standard catalog product

**TAPE AND REEL INFORMATION**

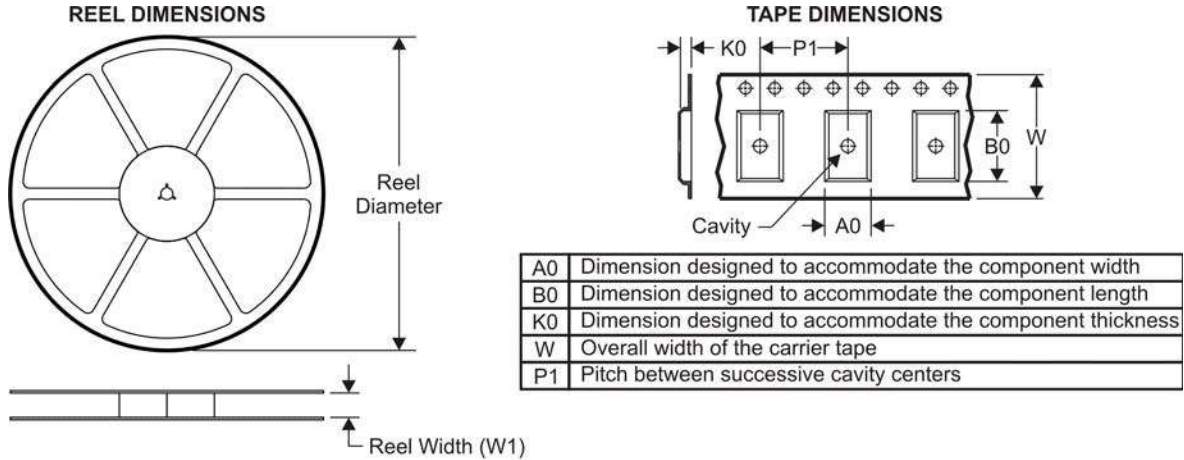

**QUADRANT ASSIGNMENTS FOR PIN 1 ORIENTATION IN TAPE**

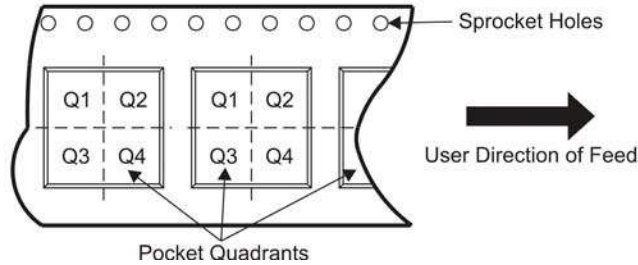

\*All dimensions are nominal

Device	Package Type	Package Drawing	Pins	SPQ	Reel Diameter (mm)	Reel Width W1 (mm)	A0 (mm)	B0 (mm)	K0 (mm)	P1 (mm)	W (mm)	Pin1 Quadrant
SN74LS157DR	SOIC	D	16	2500	330.0	16.4	6.5	10.3	2.1	8.0	16.0	Q1
SN74LS157NSR	SO	NS	16	2000	330.0	16.4	8.2	10.5	2.5	12.0	16.0	Q1
SN74LS158DR	SOIC	D	16	2500	330.0	16.4	6.5	10.3	2.1	8.0	16.0	Q1
SN74LS158NSR	SO	NS	16	2000	330.0	16.4	8.2	10.5	2.5	12.0	16.0	Q1
SN74S157NSR	SO	NS	16	2000	330.0	16.4	8.2	10.5	2.5	12.0	16.0	Q1

**TAPE AND REEL BOX DIMENSIONS**

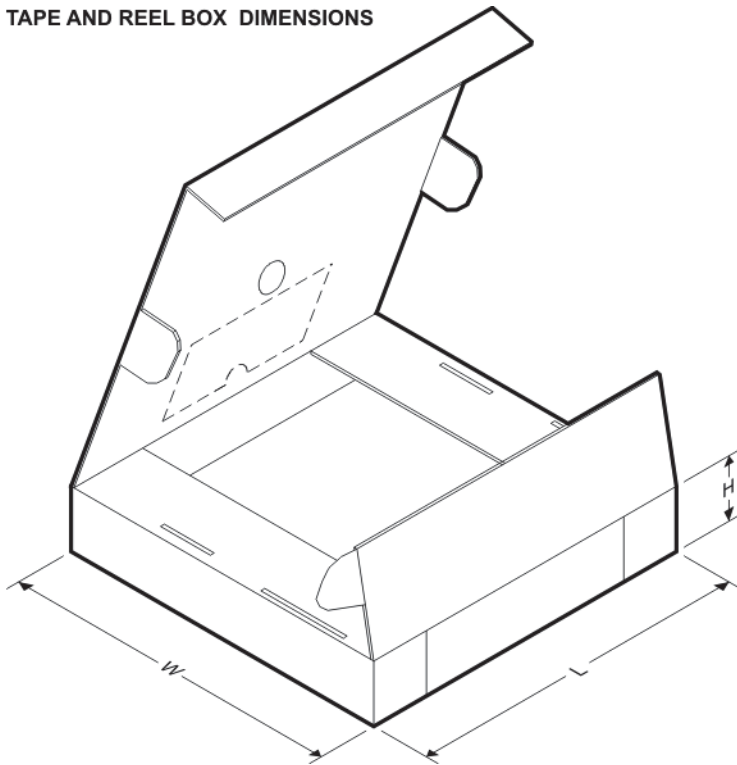

\*All dimensions are nominal

Device	Package Type	Package Drawing	Pins	SPQ	Length (mm)	Width (mm)	Height (mm)
SN74LS157DR	SOIC	D	16	2500	333.2	345.9	28.6
SN74LS157NSR	SO	NS	16	2000	346.0	346.0	33.0
SN74LS158DR	SOIC	D	16	2500	333.2	345.9	28.6
SN74LS158NSR	SO	NS	16	2000	346.0	346.0	33.0
SN74S157NSR	SO	NS	16	2000	346.0	346.0	33.0

# J (R-GDIP-T\*\*)

14 LEADS SHOWN

# CERAMIC DUAL IN-LINE PACKAGE

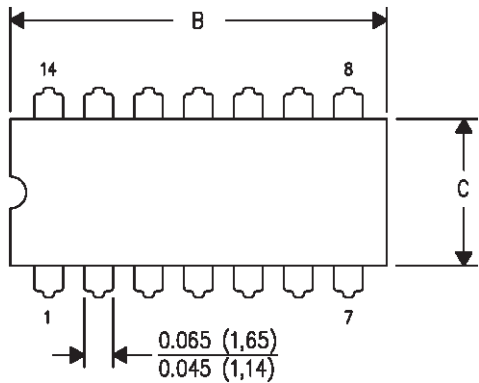

M	14	16	18	20
	0.300 (7,62) BSC	0.300 (7,62) BSC	0.300 (7,62) BSC	0.300 (7,62) BSC
B MAX	0.785 (19,94)	.840 (21,34)	0.960 (24,38)	1.060 (26,92)
B MIN	—	—	—	—
C MAX	0.300 (7,62)	0.300 (7,62)	0.310 (7,87)	0.300 (7,62)
C MIN	0.245 (6,22)	0.245 (6,22)	0.220 (5,59)	0.245 (6,22)

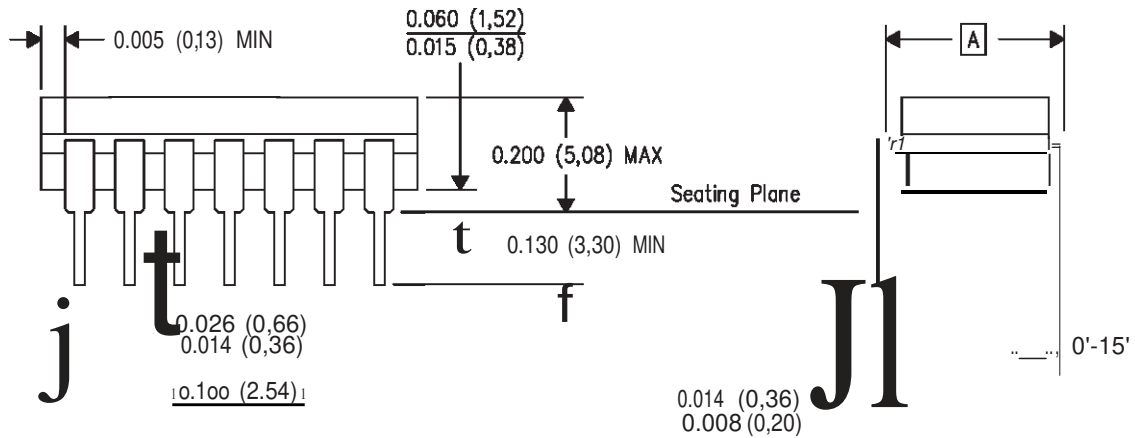

4040083/F 03/03

- NOTES:
- All linear dimensions are in inches (millimeters).
  - This drawing is subject to change without notice.
  - This package is hermetically sealed with a ceramic lid using glass frit.
  - Index point is provided on cap for terminal identification only on press ceramic glass frit seal only.
  - Falls within MIL SID 1835 GDIP1-T14, GDIP1-T16, GDIP1-T18 and GDIP1-T20.



FK (S-CQCC-N\*\*)

LEADLESS CERAMIC CHIP CARRIER

28 TERMINAL SHOWN

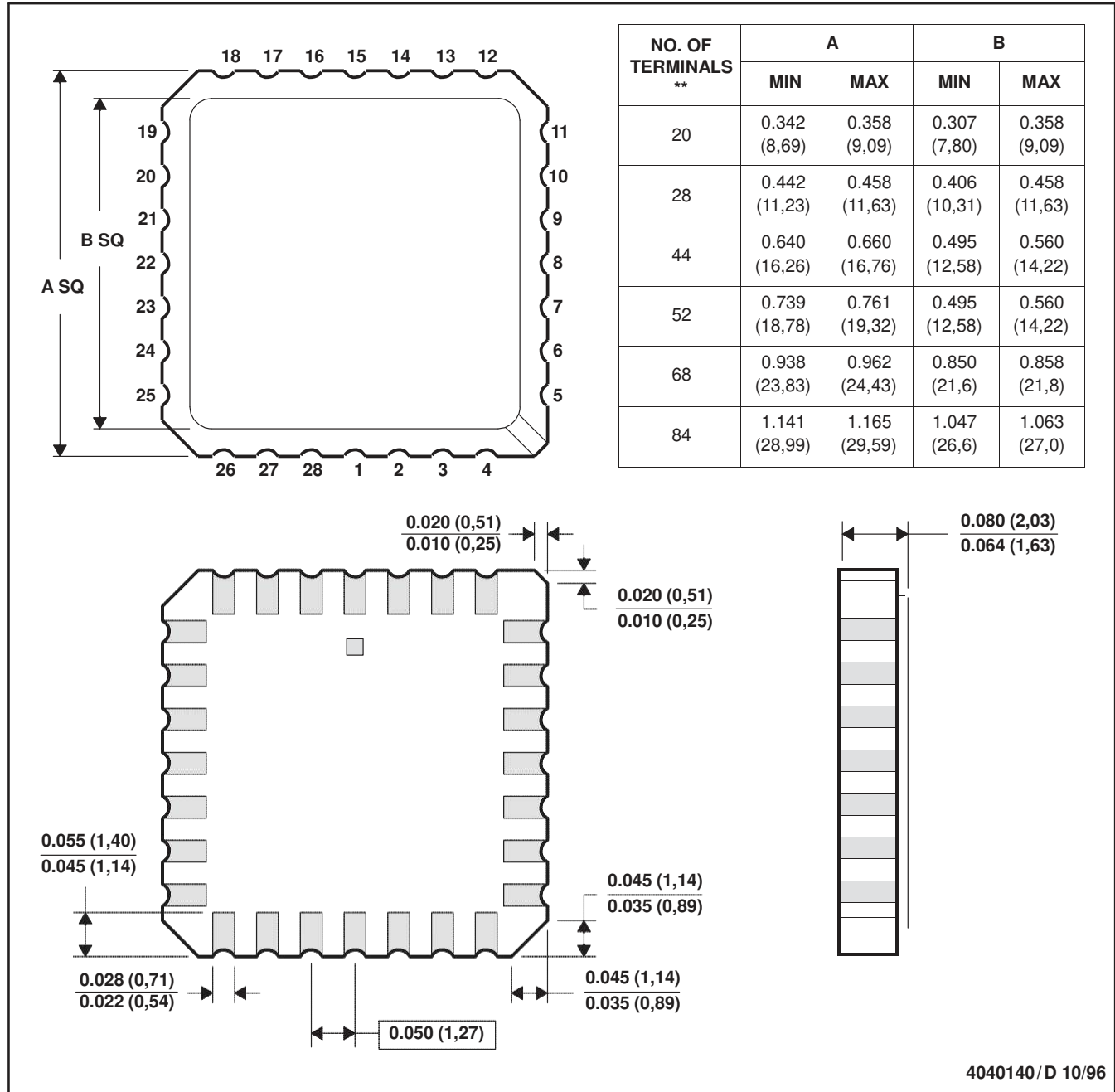

- NOTES: A. All linear dimensions are in inches (millimeters).  
 B. This drawing is subject to change without notice.  
 C. This package can be hermetically sealed with a metal lid.  
 D. The terminals are gold plated.  
 E. Falls within JEDEC MS-004

MECHANICAL DATA

NS (R-PDSO-G.,  
14-PINS SHOWN

PLASTIC SMAU.-OUTUNE PACKAGE

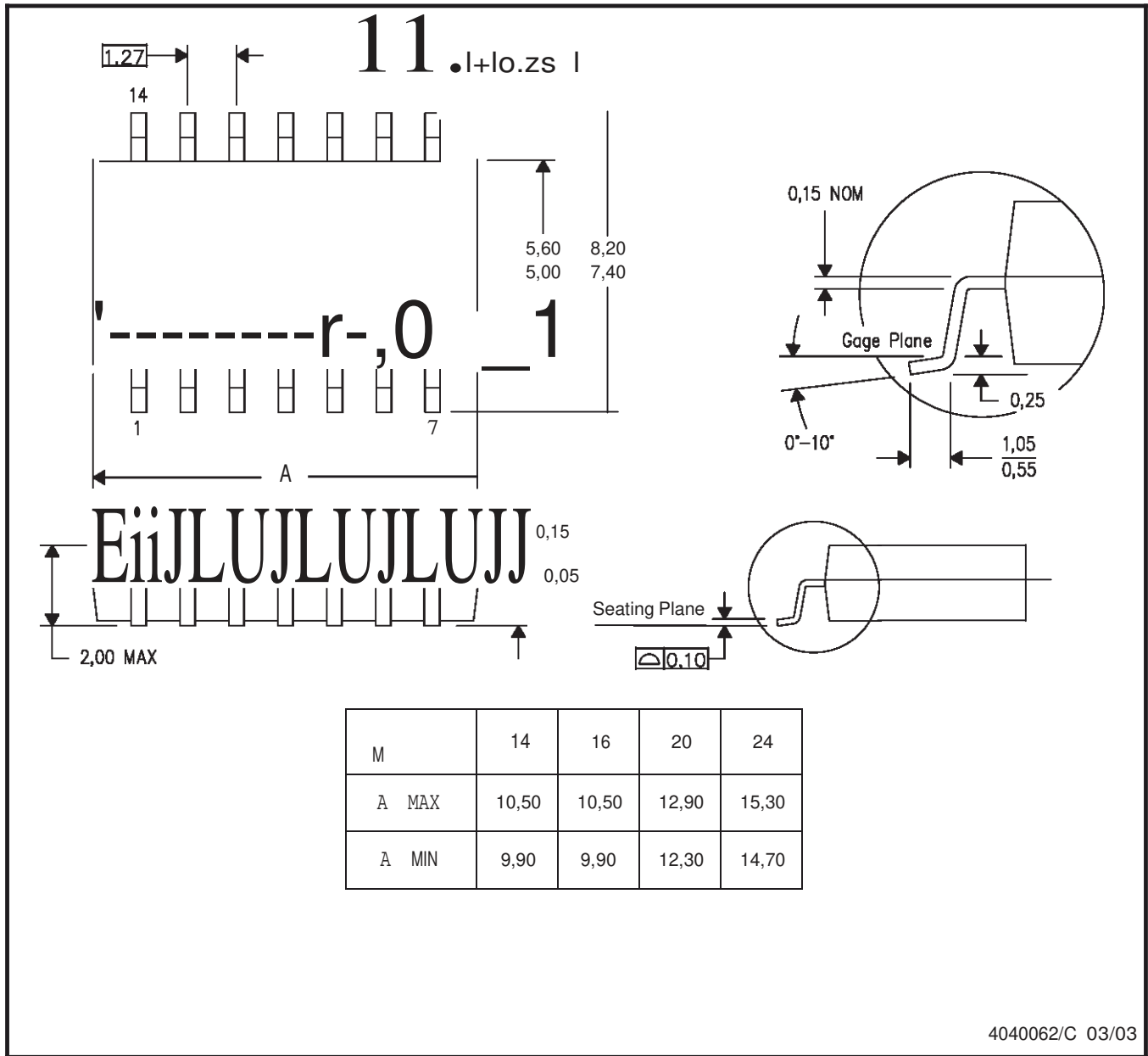

- NOTES:
- A. All linear dimensions are in millimeters.
  - B. This drawing is subject to change without notice.
  - C. Body dimensions do not include mold flash or protrusion, not to exceed 0,15.

W (R-GDFP-F16)

CERAMIC DUAL FLAIPACK

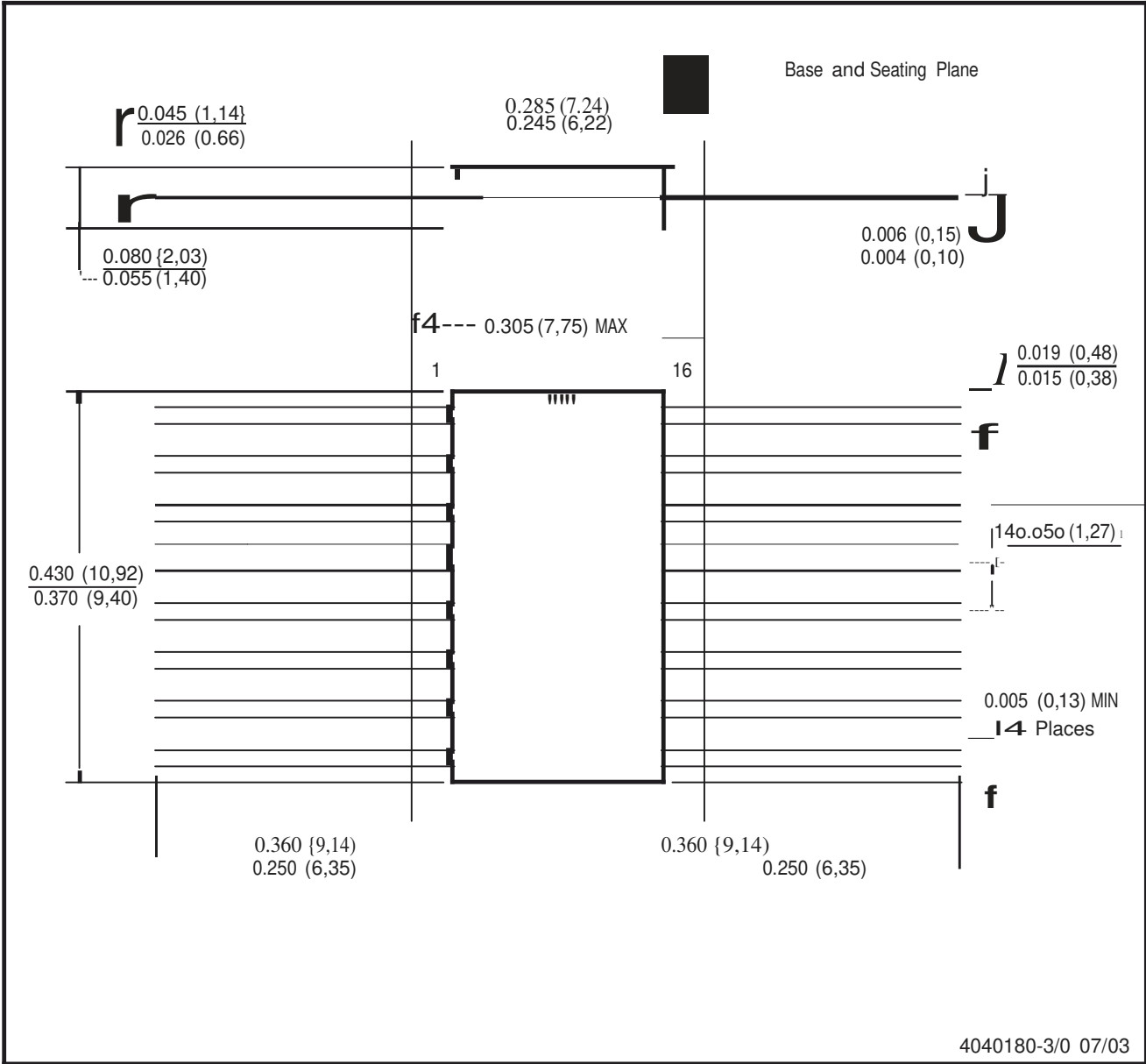

- NOTES:
- A. All linear dimensions are in inches (millimeters).
  - B. This drawing is subject to change without notice.
  - C. This package can be hermetically sealed with a ceramic lid using glass frit.
  - D. Index point is provided on cap for terminal identification only.
  - E. Falls within MIL STD 1835 GDFP1-F16 and JEDEC M0-092AC

0 (R-POSO-G16)

PLASTIC SMALL-OUTLINE PACKAGE

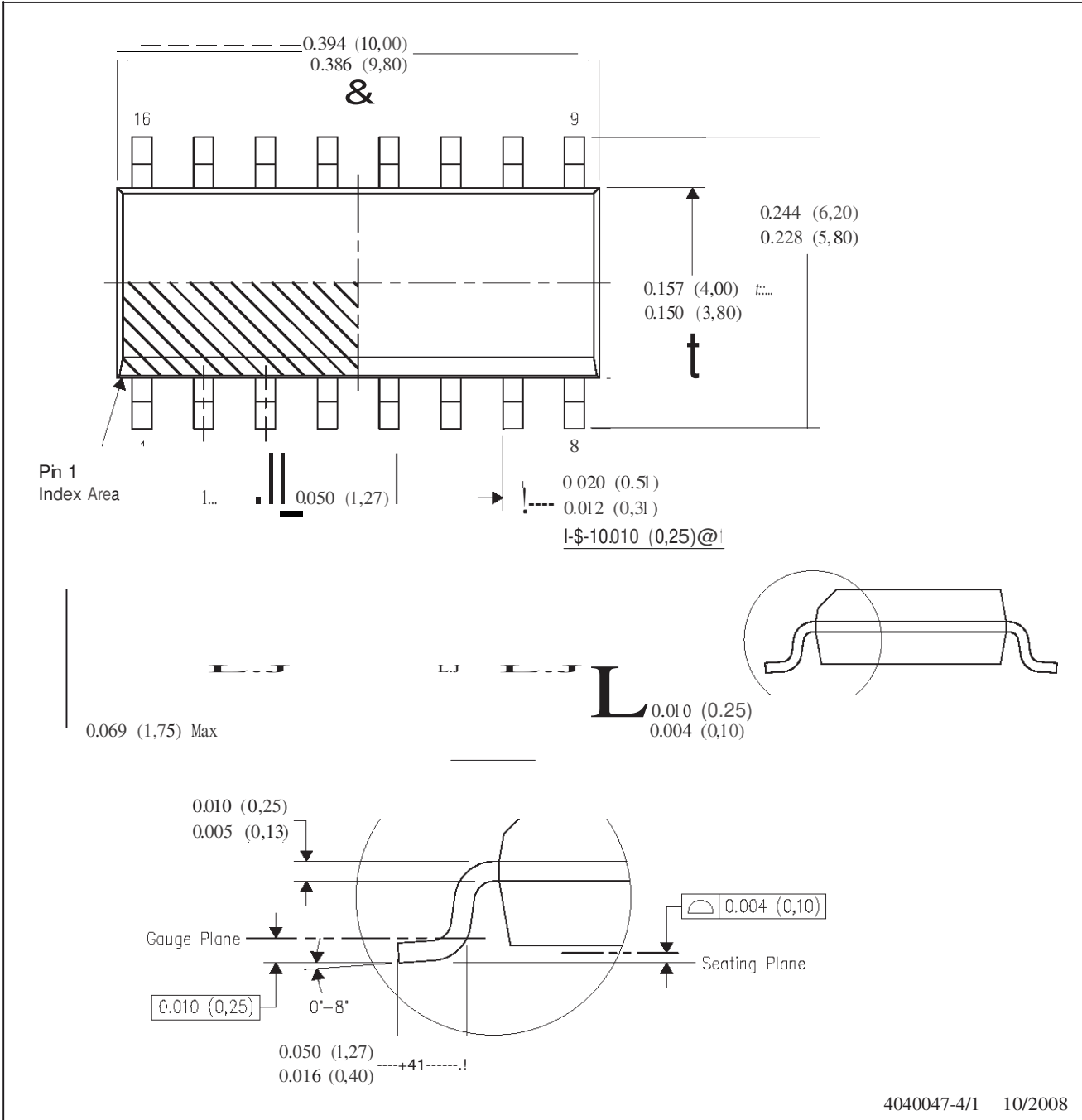

4040047-4/1 10/2008

- NOTES:
- A. All linear dimensions are in inches (millimeters).
  - B. This drawing is subject to change without notice.
  - & Body length does not include mold flash, protrusions, or gate burrs. Mold flash, protrusions, or gate burrs shall not exceed .006 (0,15) per end.
  - £ Body width does not include interlead flash. Interlead flash shall not exceed .017 (0,43) per side.
  - E. Reference JEDEC MS-012 variation AC.

D(R-PDSO-G16)

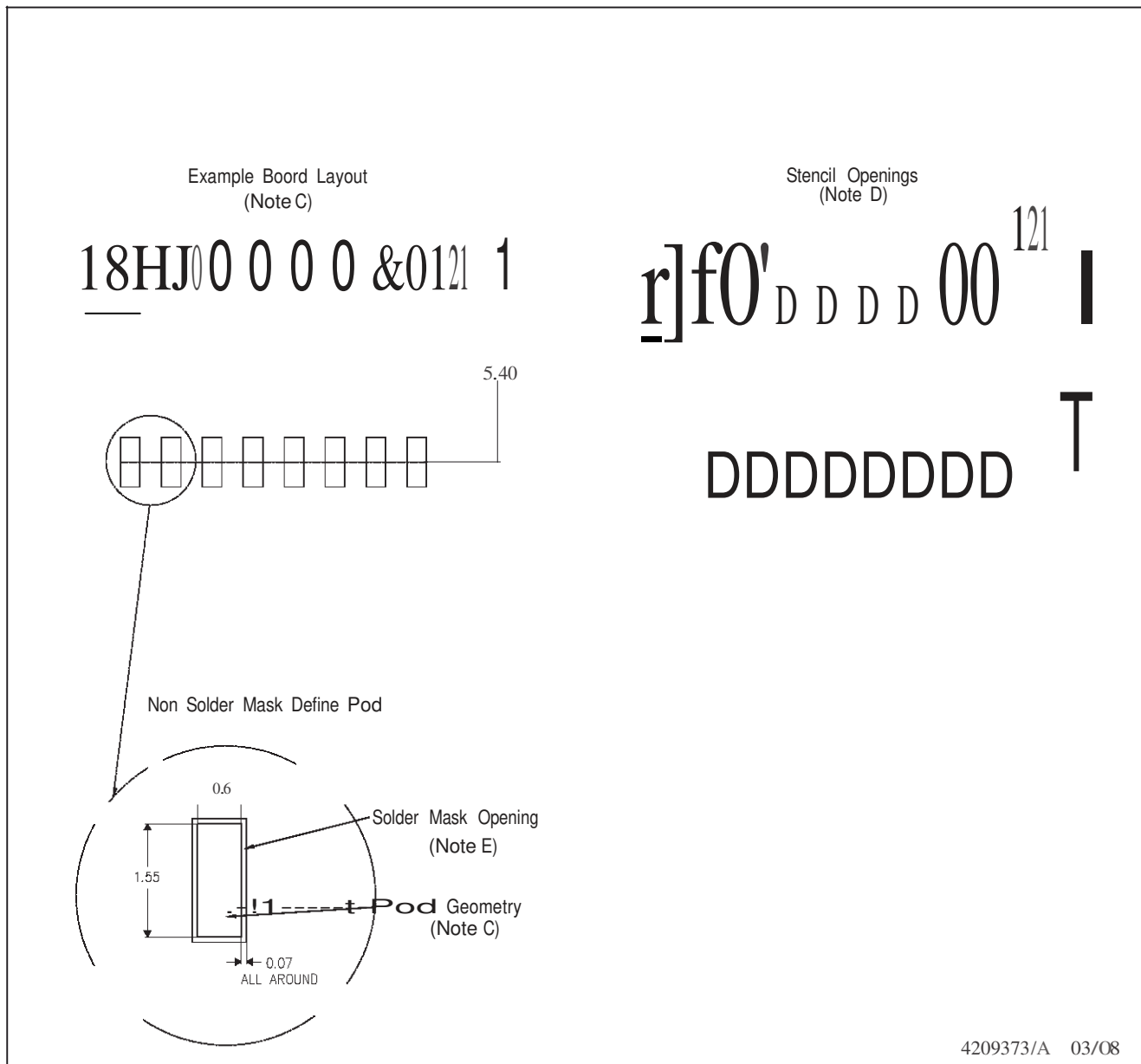

4209373/A 03/08

- N01ES:
- A. All linear dimensions are in millimeters.
  - B. This drawing is subject to change without notice.
  - C. Refer to IPC7351 for alternate board design.
  - D. Laser cutting apertures with trapezoidal walls and also rounding corners will offer better paste release. Customers should contact their board assembly site for stencil design recommendations. Refer to IPC-7525
  - E. Customers should contact their board fabrication site for solder mask tolerances between and around signal pods.

**N (R-PDIP-T\*\*)**

**PLASTIC DUAL-IN-LINE PACKAGE**

16 PINS SHOWN

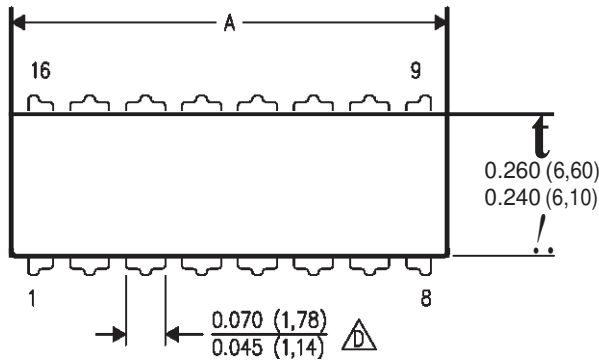

M	14	16	18	20
A tMAX	0.775 (19,69)	0.775 (19,69)	0.920 (23,37)	1.060 (26,92)
A MIN	0.745 (18,92)	0.745 (18,92)	0.850 (21,59)	0.940 (23,88)
MS-001 VARIA110N	AA	BB	AC	AD

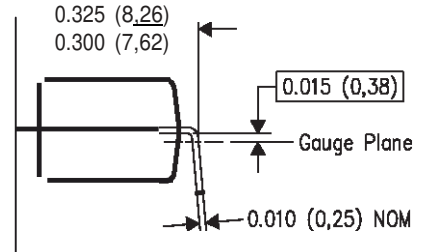
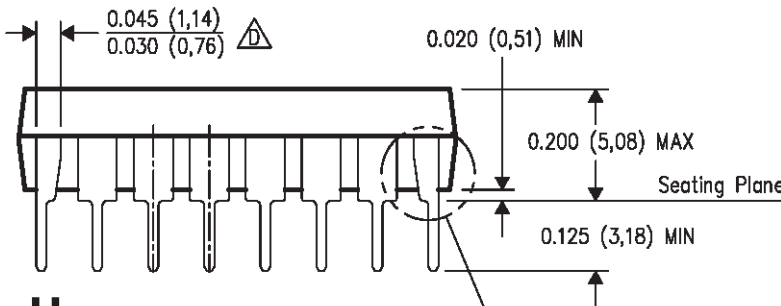

**JL**  
 0.021 (0,53)  
 0.015 (0,38)  
 I-\$-10.010 (0,25)@1

**J** 0.430 (10,92) tMAX **1.-**



4040049/E 12/2002

- NOTES: A. All linear dimensions are in inches (millimeters).  
 B. This drawing is subject to change without notice.  
*Lfu.* Falls within JEDEC MS-001, except 18 and 20 pin minimum body length (Dim A).  
 The 20 pin end lead shoulder width is a vendor option, either half or full width.

## IMPORTANT NOTICE

Texas Instruments Incorporated and its subsidiaries (TI) reserve the right to make corrections, modifications, enhancements, improvements, and other changes to its products and services at any time and to discontinue any product or service without notice. Customers should obtain the latest relevant information before placing orders and should verify that such information is current and complete. All products are sold subject to TI's terms and conditions of sale supplied at the time of order acknowledgment.

TI warrants performance of its hardware products to the specifications applicable at the time of sale in accordance with TI's standard warranty. Testing and other quality control techniques are used to the extent TI deems necessary to support this warranty. Except where mandated by government requirements, testing of all parameters of each product is not necessarily performed.

TI assumes no liability for applications assistance or customer product design. Customers are responsible for their products and applications using TI components. To minimize the risks associated with customer products and applications, customers should provide adequate design and operating safeguards.

TI does not warrant or represent that any license, either express or implied, is granted under any TI patent right, copyright, mask work right, or other TI intellectual property right relating to any combination, machine, or process in which TI products or services are used. Information published by TI regarding third-party products or services does not constitute a license from TI to use such products or services or a warranty or endorsement thereof. Use of such information may require a license from a third party under the patents or other intellectual property of the third party, or a license from TI under the patents or other intellectual property of TI.

Reproduction of TI information in TI data books or data sheets is permissible only if reproduction is without alteration and is accompanied by all associated warranties, conditions, limitations, and notices. Reproduction of this information with alteration is an unfair and deceptive business practice. TI is not responsible or liable for such altered documentation. Information of third parties may be subject to additional restrictions.

Resale of TI products or services with statements different from or beyond the parameters stated by TI for that product or service voids all express and any implied warranties for the associated TI product or service and is an unfair and deceptive business practice. TI is not responsible or liable for any such statements.

TI products are not authorized for use in safety-critical applications (such as life support) where a failure of the TI product would reasonably be expected to cause severe personal injury or death, unless officers of the parties have executed an agreement specifically governing such use. Buyers represent that they have all necessary expertise in the safety and regulatory ramifications of their applications, and acknowledge and agree that they are solely responsible for all legal, regulatory and safety-related requirements concerning their products and any use of TI products in such safety-critical applications, notwithstanding any applications-related information or support that may be provided by TI. Further, Buyers must fully indemnify TI and its representatives against any damages arising out of the use of TI products in such safety-critical applications.

TI products are neither designed nor intended for use in military/aerospace applications or environments unless the TI products are specifically designated by TI as military-grade or "enhanced plastic." Only products designated by TI as military-grade meet military specifications. Buyers acknowledge and agree that any such use of TI products which TI has not designated as military-grade is solely at the Buyer's risk, and that they are solely responsible for compliance with all legal and regulatory requirements in connection with such use.

TI products are neither designed nor intended for use in automotive applications or environments unless the specific TI products are designated by TI as compliant with ISO/TS 16949 requirements. Buyers acknowledge and agree that, if they use any non-designated products in automotive applications, TI will not be responsible for any failure to meet such requirements.

Following are URLs where you can obtain information on other Texas Instruments products and application solutions:

### Products

Amplifiers	<a href="http://amplifier.ti.com">amplifier.ti.com</a>
Data Converters	<a href="http://dataconverter.ti.com">dataconverter.ti.com</a>
DSP	<a href="http://dsp.ti.com">dsp.ti.com</a>
Clocks and Timers	<a href="http://www.ti.com/clocks">www.ti.com/clocks</a>
Interface	<a href="http://interface.ti.com">interface.ti.com</a>
Logic	<a href="http://logic.ti.com">logic.ti.com</a>
Power Mgmt	<a href="http://power.ti.com">power.ti.com</a>
Microcontrollers	<a href="http://microcontroller.ti.com">microcontroller.ti.com</a>
RFID	<a href="http://www.ti-rfid.com">www.ti-rfid.com</a>
RF/IF and ZigBee® Solutions	<a href="http://www.ti.com/lprf">www.ti.com/lprf</a>

### Applications

Audio	<a href="http://www.ti.com/audio">www.ti.com/audio</a>
Automotive	<a href="http://www.ti.com/automotive">www.ti.com/automotive</a>
Broadband	<a href="http://www.ti.com/broadband">www.ti.com/broadband</a>
Digital Control	<a href="http://www.ti.com/digitalcontrol">www.ti.com/digitalcontrol</a>
Medical	<a href="http://www.ti.com/medical">www.ti.com/medical</a>
Military	<a href="http://www.ti.com/military">www.ti.com/military</a>
Optical Networking	<a href="http://www.ti.com/opticalnetwork">www.ti.com/opticalnetwork</a>
Security	<a href="http://www.ti.com/security">www.ti.com/security</a>
Telephony	<a href="http://www.ti.com/telephony">www.ti.com/telephony</a>
Video & Imaging	<a href="http://www.ti.com/video">www.ti.com/video</a>
Wireless	<a href="http://www.ti.com/wireless">www.ti.com/wireless</a>

Mailing Address: Texas Instruments, Post Office Box 655303, Dallas, Texas 75265  
Copyright © 2008, Texas Instruments Incorporated