

REV.	FX-778410/419	
SHEET 1 OF 5	DOCUMENT NO.	
REVISIONS M		
LTR	DESCRIPTION	DATE
A	INITIAL RELEASE	

TYPE I

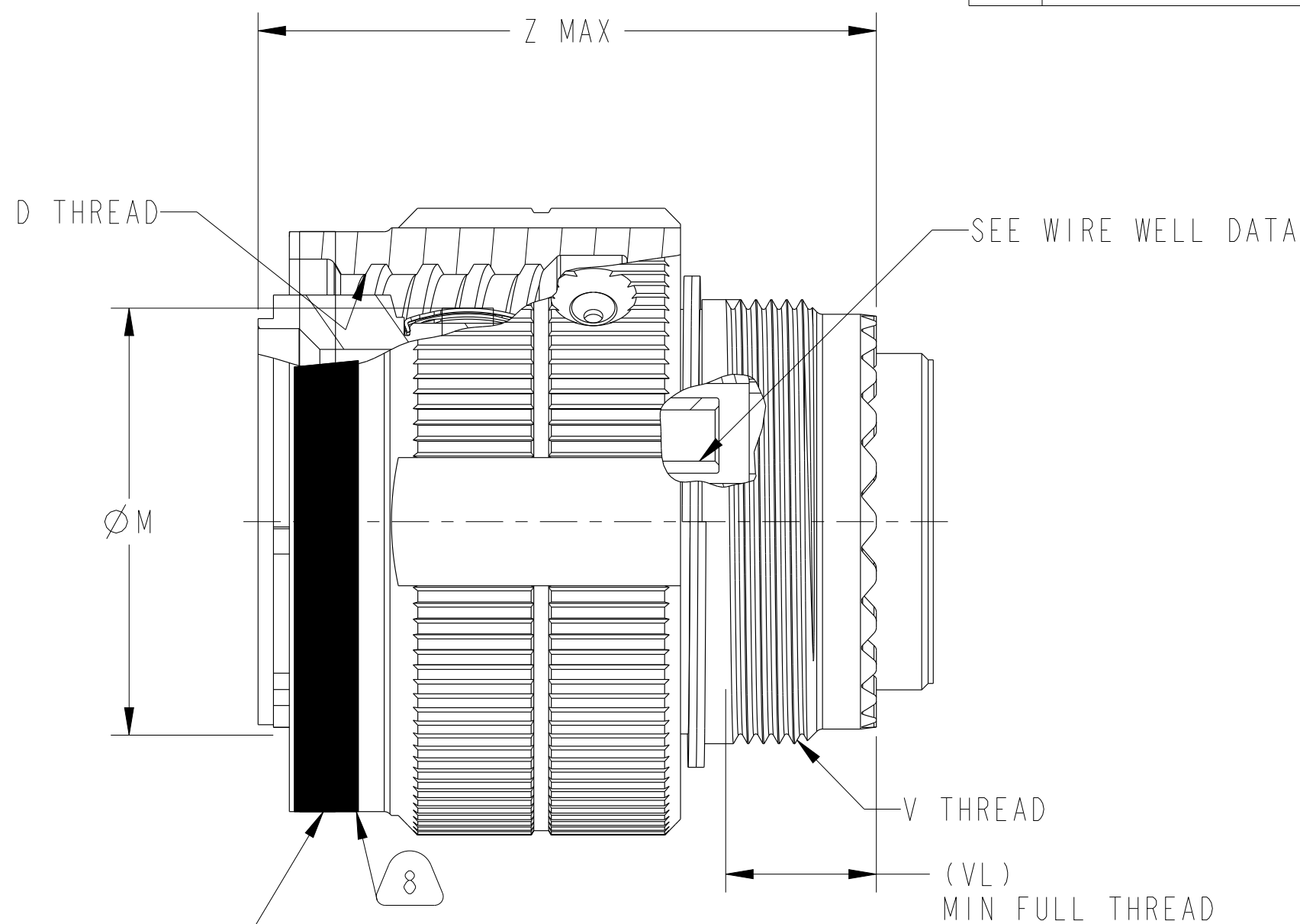

STAMP "AMPHENOL", CODED NUMBER, DATE
 CODE AND LOT NUMBER (9-3895) PER
 9-5788.
 EXAMPLE:
 AMPHENOL HV06RF15-54P 2020 20001000
 FOR ROTATED KEYWAYS
 EXAMPLE:
 AMPHENOL HV06RF15-54PA 2020 20001000

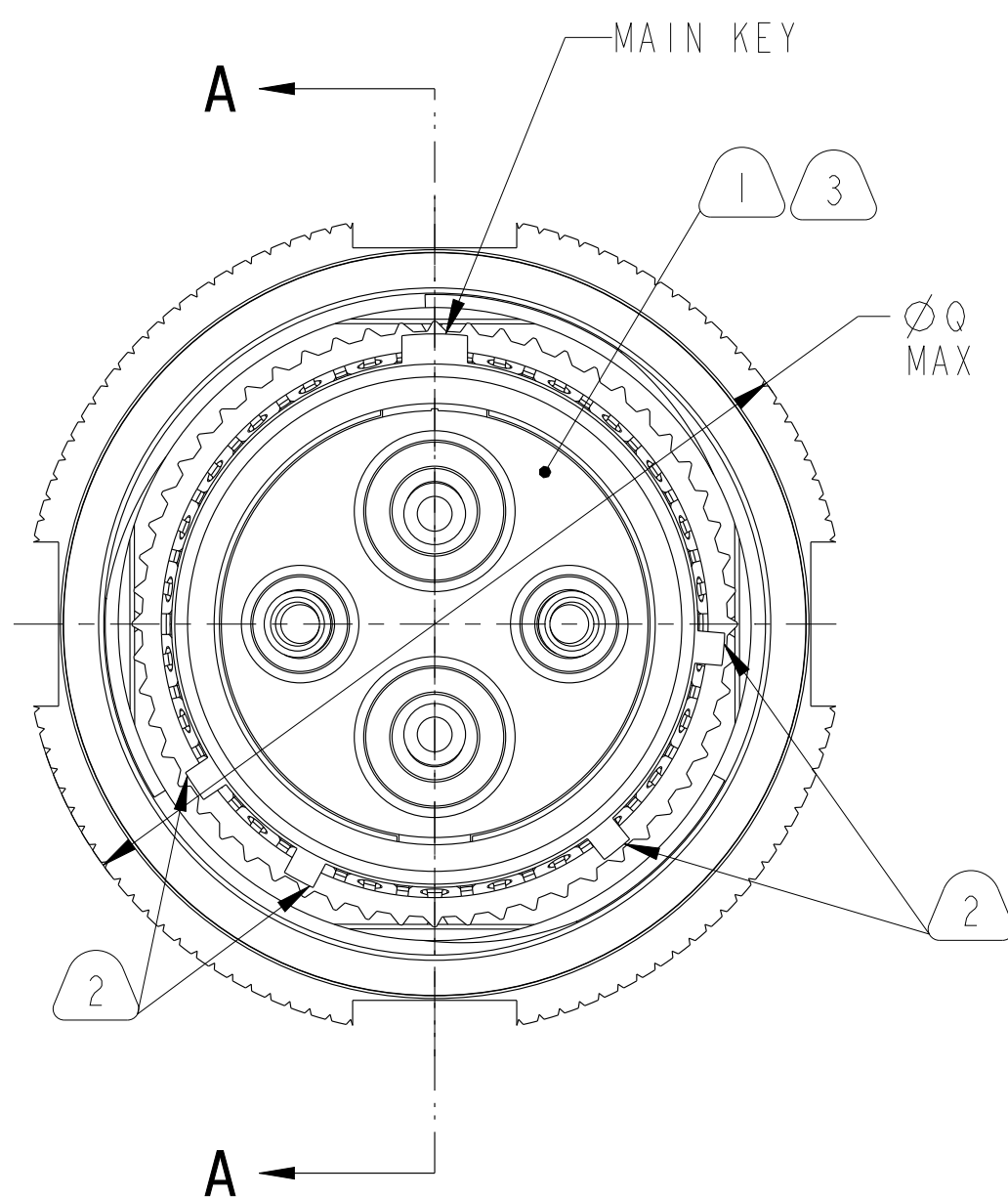

PARTIAL SECTION A-A

**PRELIMINARY
 DRAWING
 REVISION: P-2**

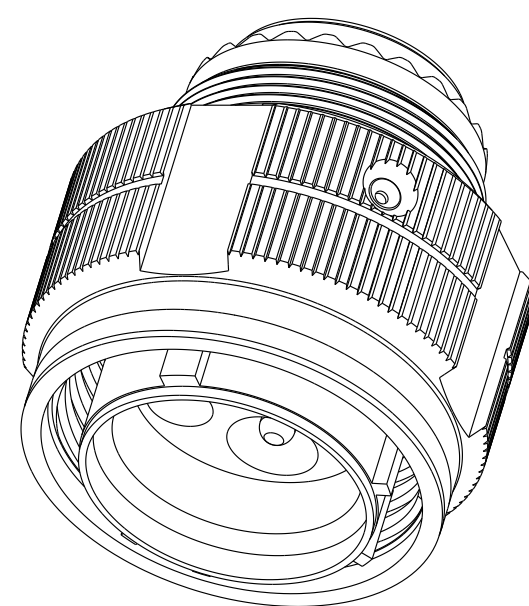

**ISOMETRIC VIEW
 SCALE 2.0**

NOTES: SEE SHEET 5

THE USE OF THIS DOCUMENT IS UNLIMITED.
 HOWEVER, DOCUMENTS REFERENCED HEREON
 MAY CONTAIN LIMITED RIGHTS DATA.

NONE
 NEXT ASSEMBLY

PRO/ENGINEER INFORMATION
 Pro/e Model Used:
 HV06RF15-54P.ASSEM
 Drawing Name:
 FX-778410.419

UNLESS OTHERWISE SPECIFIED	SPECIFICATIONS	POS	QTY	PART NUMBER	DESCRIPTION	NOTE
LINEAR DIMENSIONS ARE IN INCHES TOLERANCES: .XXXX = ±.0005 ANGLES= ±2° .XXX = ±.010 .XX = ±.03 .X = ±.1 DIM. & TOL. PER ASME Y14.5M; DRM PER MIL-STD-31000; OTHER Amphenol Stds. PER 9-3800 LEGENDS: =FLAG NOTE CALL OUT REFERENCE ONLY	MATERIAL SPEC. NONE	APPROVALS		DATE	PARTS LIST	
	PROCESS SPEC. SEE NOTE 6	PREPARED BY J.LEVIN	ENGINEER IN CHARGE B.BALDWIN	23-Feb-21	AMPHENOL CORPORATION 40-60 DELAWARE AVENUE SIDNEY, N.Y. 13838 CONNECTOR, ELECTRICAL, PLUG STRAIGHT PLUG, ALUMINUM HV38999	
		DESIGN MANAGER B.BALDWIN	DESIGN ACTIVITY GROUP COM-AIR		SIZE C	CAGE CODE 77820
		THIRD ANGLE PROJECTION			DOCUMENT NO. FX-778410/419	REV. -
					SCALE: 3.5	REF. 91-684320/329
					SHEET 1 OF 5	

DOCUMENT NO.
FX-778410/419

SHEET 1 OF 5

REV.

C

B

A

FORMAT: C-U-E-1

D

C

REVISION

REVISION

Eng. PDM Information
For Reference Only

REV.

SHEET 1 OF 5

DOCUMENT NO.
FX-778410/419

TYPE II

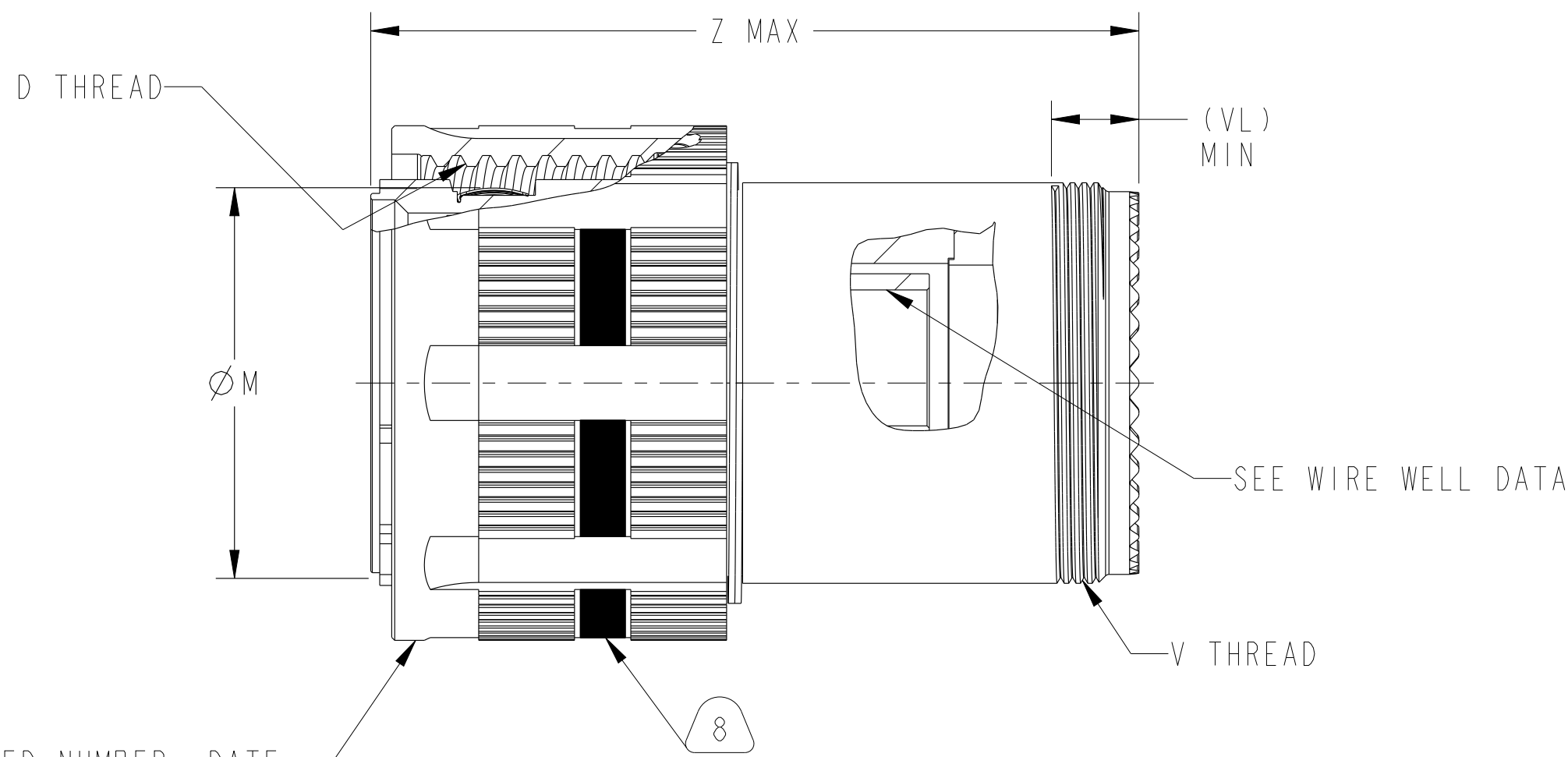
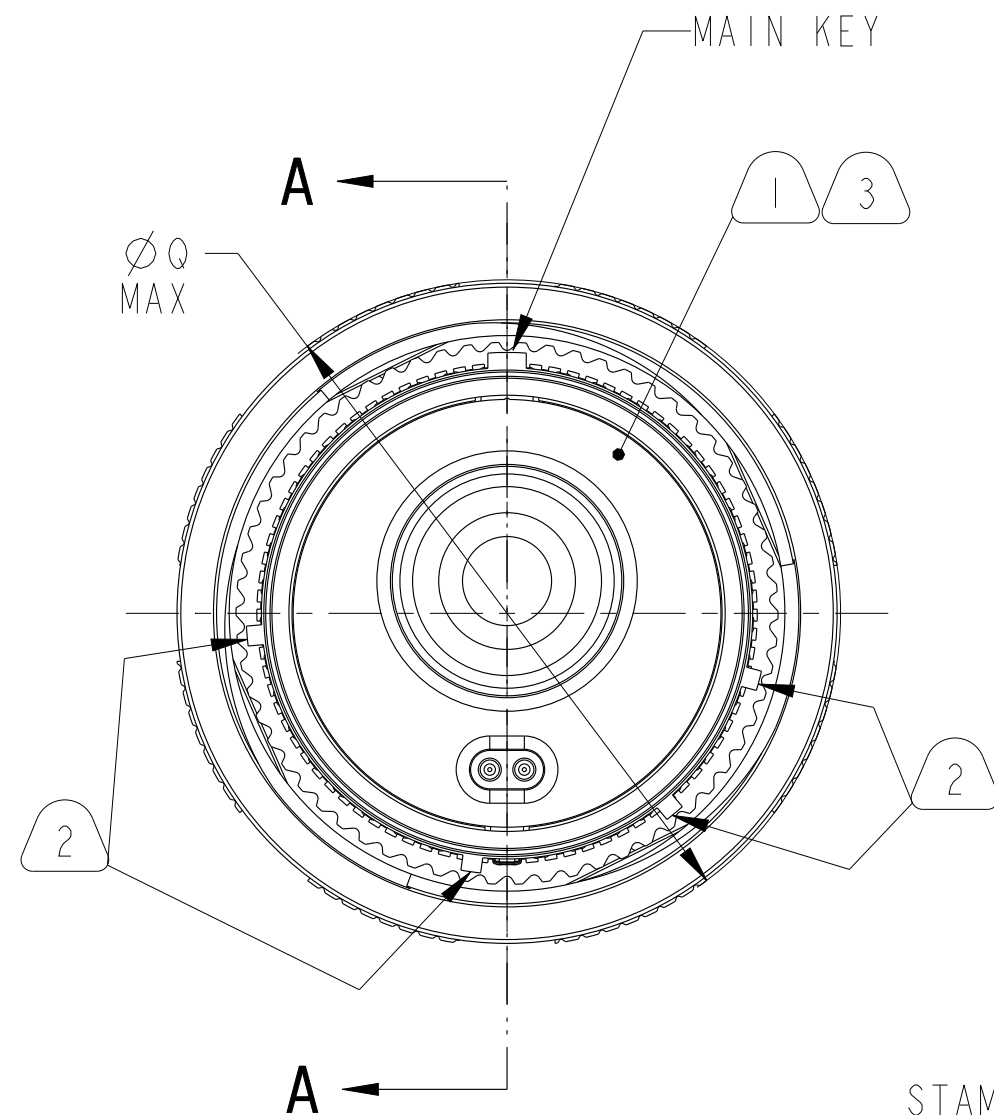

STAMP "AMPHENOL", CODED NUMBER, DATE
 CODE AND LOT NUMBER (9-3895) PER
 9-5788.
 EXAMPLE:
 AMPHENOL HV06RF23-59P 2020 20001000
 FOR ROTATED KEYWAYS
 EXAMPLE:
 AMPHENOL HV06RF23-59PA 2020 20001000

5 10

PARTIAL SECTION A-A

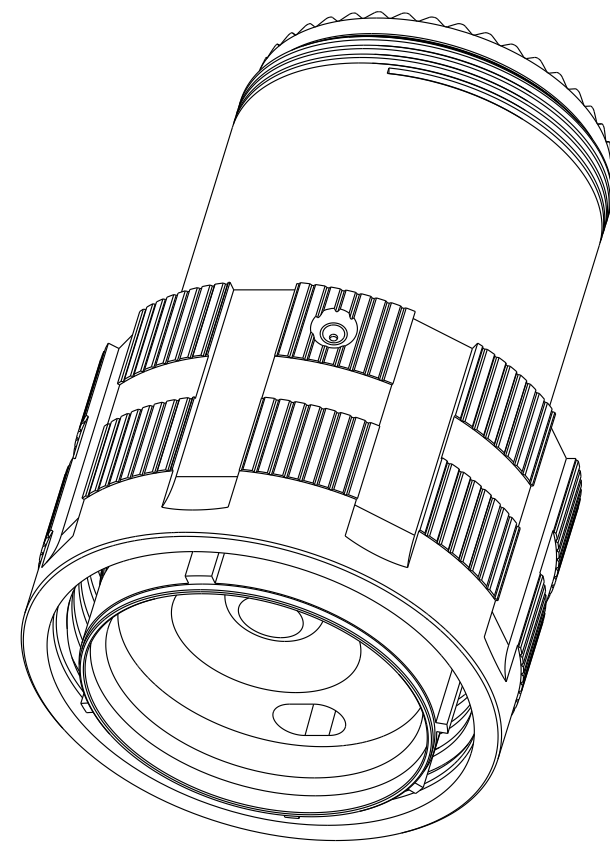

ISOMETRIC VIEW
SCALE 1.5

NOTES: SEE SHEET 5

THE USE OF THIS DOCUMENT IS UNLIMITED.
HOWEVER, DOCUMENTS REFERENCED HEREON
MAY CONTAIN LIMITED RIGHTS DATA.

PRELIMINARY
DRAWING
REVISION: P-2

FX-778410/419

SHEET 2 OF 5

REV.

C

B

A

FORMAT: C-0-U-E-1

DOCUMENT NO.
FX-778410/419

SHEET 2 OF 5

REV.

-

SIZE C	CAGE CODE 77820	DOCUMENT NO. FX-778410/419	REV. -
SCALE: 2.0		REF: 91-684320/329	SHEET 2 OF 5

DOCUMENT NO.
FX-778410/419

SHEET 2 OF 5

REV. -

Eng. PDM Information
For Reference Only

REVISION .

VERSION 2

FX-778410/419

SHEET 3 OF 5

REV.

C

B

A

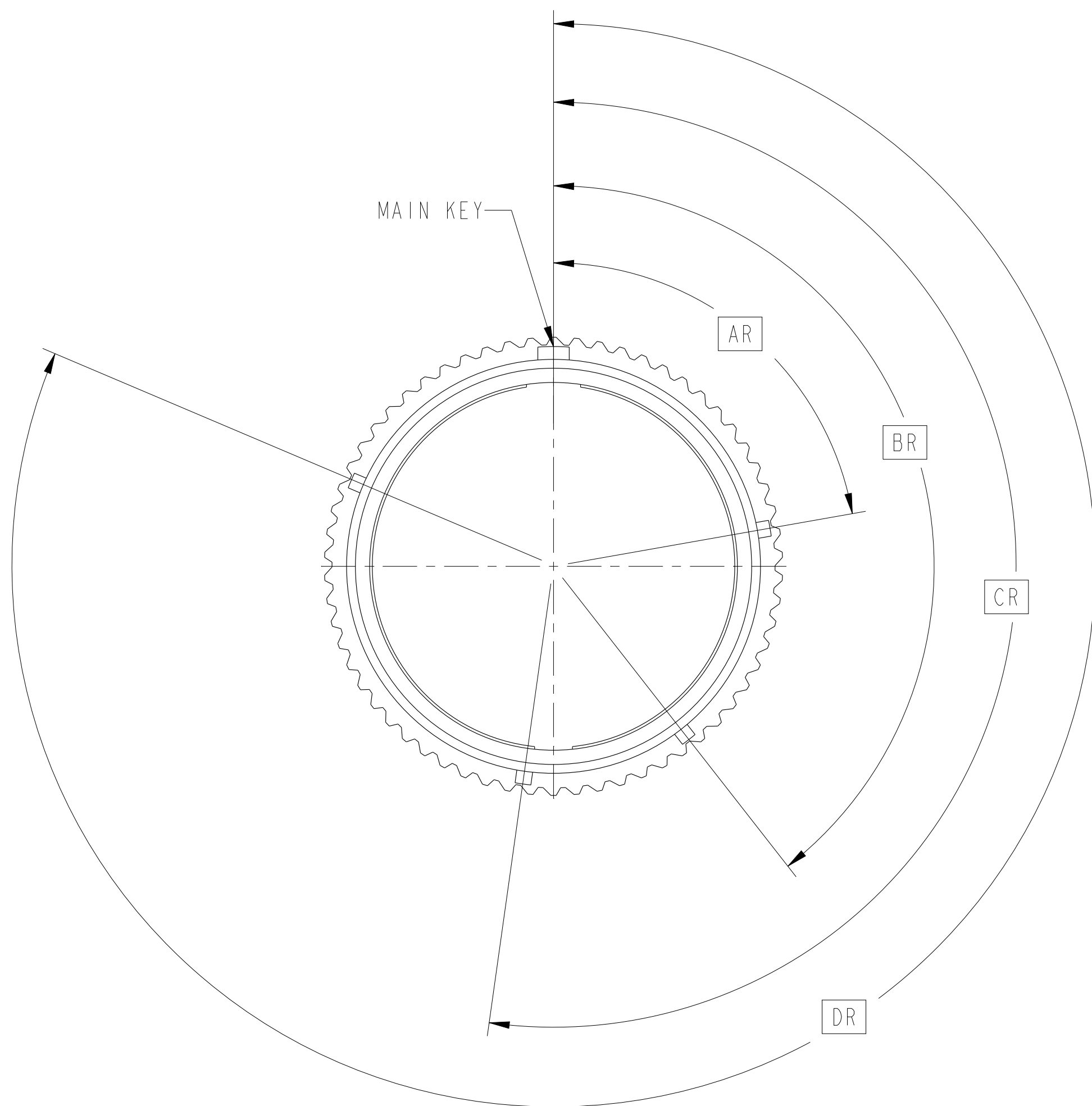

PRELIMINARY
DRAWING
REVISION: P-2

NOTES: SEE SHEET 5

THE USE OF THIS DOCUMENT IS UNLIMITED.
HOWEVER, DOCUMENTS REFERENCED HEREON
MAY CONTAIN LIMITED RIGHTS DATA.

TYPE I					
MINOR KEYWAY LOCATION TABLE					
SHELL SIZE	KEYWAY ARRANGEMENT IDENT. LETTER	AR°	BR°	CR°	DR°
		NORMAL	95	141	208
11 THROUGH 15	A	113	156	182	292
	B	90	145	195	252
	C	53	156	220	255
	D	119	146	176	298
	E	51	141	184	242
17 THROUGH 25	NORMAL	80	142	196	293
	A	135	170	200	310
	B	49	169	200	244
	C	66	140	200	257
	D	62	145	180	280
	E	79	153	197	272

TYPE II				
MINOR KEYWAY LOCATION TABLE				
KEYWAY ARRANGEMENT IDENT. LETTER	AR°	BR°	CR°	DR°
NORMAL	80	142	188	293
A	135	170		310
B	49	169		244
C	66	140		257
D	62	145		280
E	79	153		272

SIZE C	CAGE CODE 77820	DOCUMENT NO. FX-778410/419	REV. -
SCALE: 3.0		REF: 91-684320/329	SHEET 3 OF 5

FORMAT: C-U-E-1

FX-778410/419

SHEET 3 OF 5

REV.

-

REVISION

REVISION

Eng. PDM Information For Reference Only

REV.

SHEET 3 OF 5

FX-778410/419

REV.

-

D

C

2

.

For Reference Only

-

SHEET 3 OF 5

FX-778410/419

REV.

-

FX-778410/419

SHEET 4 OF 5

REV.

C

B

A

FORMAT: C-0-E-1

ASSEMBLY NUMBER	CUSTOMER NUMBER	SHELL SIZE	CONNECTOR TYPE 	D THREAD		ØM MIN OVER TINES	ØO MAX	Z MAX	V THREAD	(VL) MIN
				SIZE CLASS 2B	MODIFIED MINOR DIA					
()-778410-()-()-()	HV06()-11-()-()-()	11	TYPE I	.7500-0.1P-0.3L-TS	.7142-.7078	.577	.969	1.234	M15 X 1-6g 0.100R	.280
			TYPE II	TBD						
()-778411-()-()-()	HV06()-13-()-()-()	13	TYPE I	.8750-0.1P-0.3L-TS	.8392-.8328	.694	1.141	1.234	M18 X 1-6g 0.100R	.280
			TYPE II	TBD						
()-778412-()-()-()	HV06()-15-()-()-()	15	TYPE I	1.000-0.1P-0.3L-TS	.9642-.9578	.819	1.266	1.234	M22 X 1-6g 0.100R	.280
			TYPE II	TBD						
()-778413-()-()-()	HV06()-17-()-()-()	17	TYPE I	1.1875-0.1P-0.3L-TS	1.1394-1.1344	.944	1.391	1.234	M25 X 1-6g 0.100R	.280
			TYPE II	2.579						
()-778414-()-()-()	HV06()-19-()-()-()	19	TYPE I	1.2500-0.1P-0.3L-TS	1.2020-1.1970	1.049	1.500	1.234	M28 X 1-6g 0.100R	.280
			TYPE II	2.579						
()-778415-()-()-()	HV06()-21-()-()-()	21	TYPE I	1.3750-0.1P-0.3L-TS	1.3270-1.3220	1.174	1.625	1.234	M31 X 1-6g 0.100R	.280
			TYPE II	2.579						
()-778416-()-()-()	HV06()-23-()-()-()	23	TYPE I	1.5000-0.1P-0.3L-TS	1.4520-1.4470	1.299	1.750	1.234	M34 X 1-6g 0.100R	.280
			TYPE II	2.579						
()-778417-()-()-()	HV06()-25-()-()-()	25	TYPE I	1.6250-0.1P-0.3L-TS	1.5770-1.5720	1.424	1.875	1.234	M37 X 1-6g 0.100R	.280
			TYPE II	2.579						
()-778418-()-()-()	HV06()-33-()-()-()	33	TYPE II	1.8750-0.1P-0.3L-TS	1.8270-1.8220	1.646	2.203	2.579	M45 X 1.5-6g 0.188R	.594
()-778419-()-()-()	HV06()-37-()-()-()	37	TYPE II	2.1250-0.1P-0.3L-TS	2.0770-2.0720	1.896	2.391	2.579	M50 X 1.5-6g 0.188R	.594

PRELIMINARY DRAWING REVISION: P-2

- TO COMPLETE, ADD KEY WAY ROTATION (OMIT FOR NORMAL)
- TO COMPLETE, SEE CONTACT TYPE TABLE
- TO COMPLETE, ADD INSERT ARRANGEMENT
- TO COMPLETE, SEE SERVICE CLASS TABLE
- TO COMPLETE, SEE CONTACT TYPE TABLE
- TO COMPLETE, CONTACT GENDER/SHELL ROTATION SUFFIX PER 9-2437-25
- TO COMPLETE, ADD INSERT ARRANGEMENT
- TO COMPLETE, SEE SERVICE CLASS TABLE

ASSY NO. PREFIX	CODED NO. PREFIX	FINISH
88-	RW	OLIVE DRAB NICKEL BASE
91-	RF	NICKEL PLATED
F2-	DZ	BLACK ZINC NICKEL
F7-	DT	DURMALON

ASSY NO. DESIGNATION	CODED NO. DESIGNATION	DEFINITION
OMIT	P	PIN
	S	SOCKET
A	H	HIGH PERFORMANCE SOCKET
B	R	RADSOK SOCKET
C	GP	GOLD PLATED PIN
	GS	GOLD PLATED SOCKET
E	GH	GOLD PLATED HIGH PERFORMANCE SOCKET
F	GR	GOLD PLATED RADSOK SOCKET
L	A	LESS PIN CONTACTS
	B	LESS SOCKET CONTACTS

CONTACT SIZE	22D	16	12	8	4	0
WELL DIA	.0345±.0010	.067±.001	.100±.002	.181±.002	.281±.002	.453±.002
WELL DEPTH	.141 ^{+.016} _{-.000}	.209 ^{+.020} _{-.000}	.209 ^{+.020} _{-.000}	.490 ^{+.015} _{-.000}	.580 ^{+.020} _{-.000}	

NOTES: SEE SHEET 5

THE USE OF THIS DOCUMENT IS UNLIMITED. HOWEVER, DOCUMENTS REFERENCED HEREON MAY CONTAIN LIMITED RIGHTS DATA.

FX-778410/419 SHEET 4 OF 5 REV. -

FX-778410/419

SHEET 5 OF 5

REV.

C

B

A

EXPLANATION OF PART NUMBER

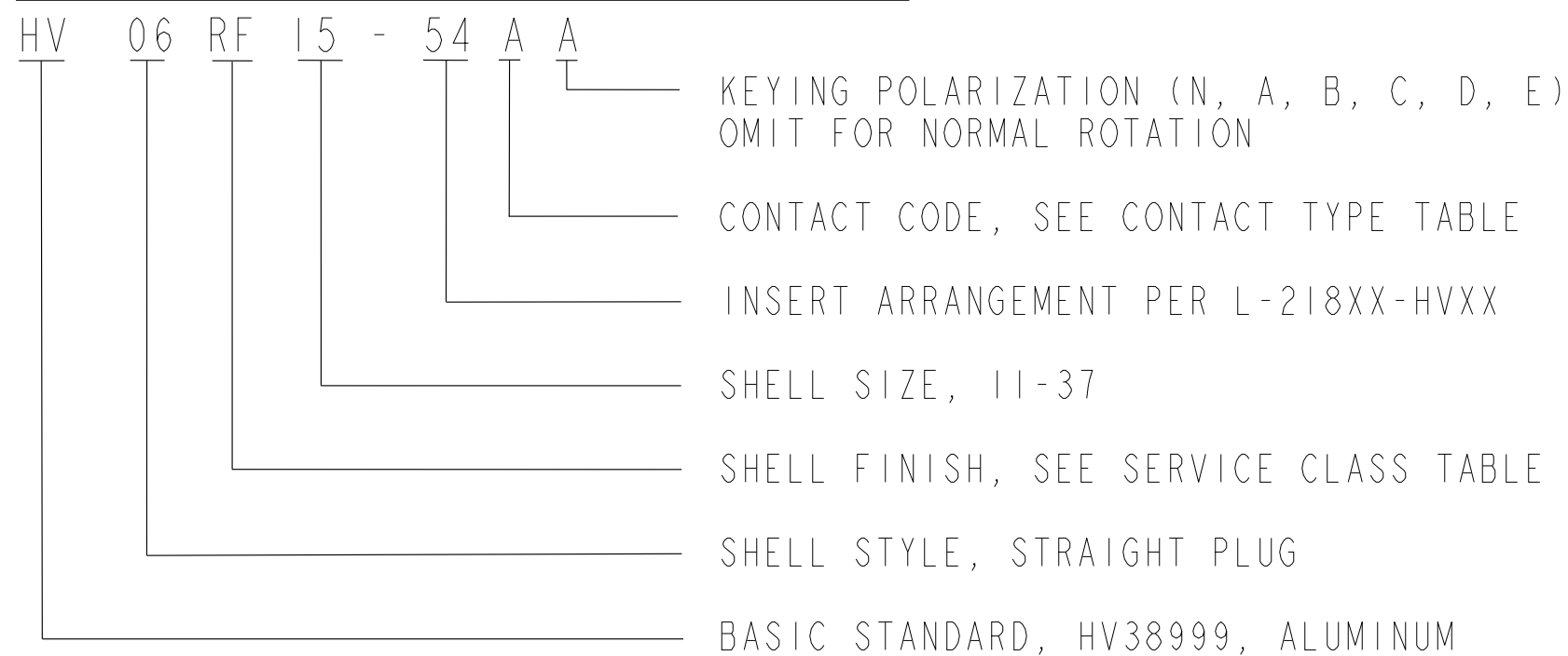

EXPLANATION OF PART NUMBER

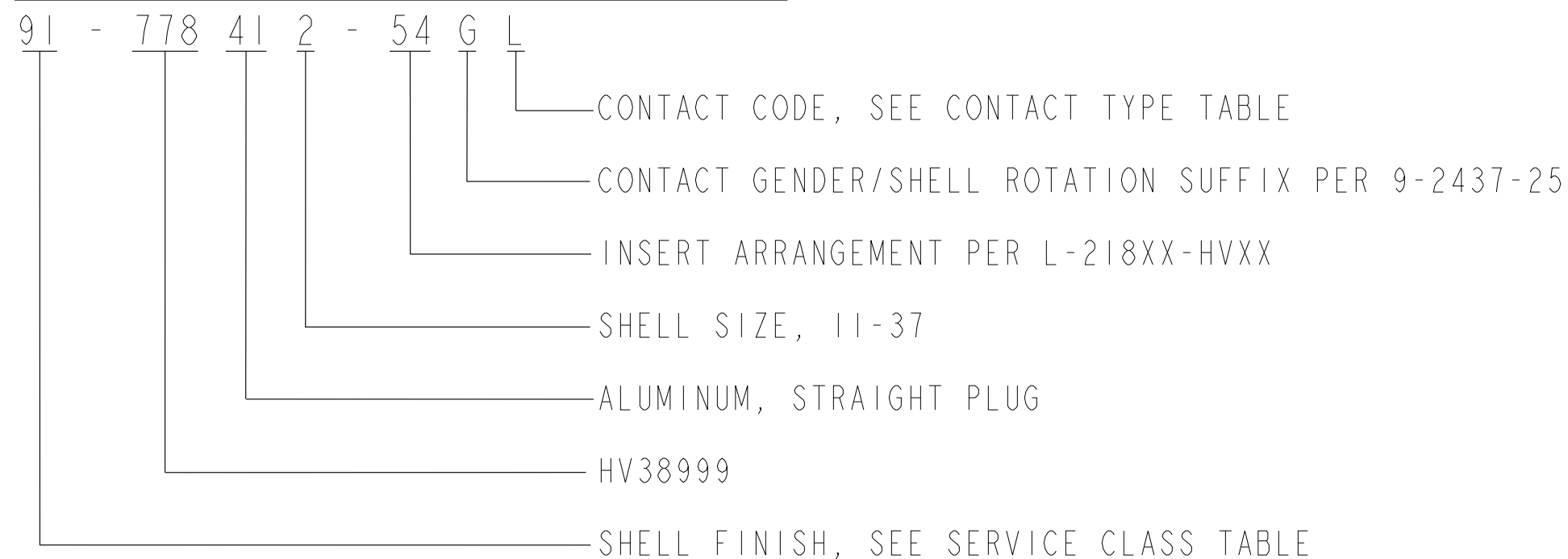

12. ALL POWER CONTACTS SUPPLIED TO "STANDARD" ASSEMBLIES ARE SILVER PLATED. ALL INTERLOCK CONTACTS SHALL BE GOLD PLATED. FOR CONTACTS SIZE 22D THROUGH 12 REFERENCE AS39029/56 AND AS39029/58. FOR CONTACTS SIZE 8 THROUGH 0 REFERENCE AS39029/29 AND AS39029/30.

11. CONNECTORS CONTAINING CONTACTS SIZE 8 OR LARGER SHALL BE TYPE II.

10. SEE WORK ORDER FOR PERMISSIBLE ADDITIONAL OR ALTERNATE STAMPING.

9. UNITS ILLUSTRATED MEET OR EXCEED THE APPLICABLE REQUIREMENTS OF MIL-DTL-38999.

8. BLUE BAND DENOTES REAR RELEASE CONTACT RETENTION SYSTEM.

7. FOR MATING CONNECTOR, SEE FX-778430/439.

6. PROCESS SPEC:
9-2437-25, 9-5788, 9-3895

5. PACKAGE PER PRODUCTION PROCESS SHEET.

4. DRAWING ILLUSTRATES FINAL ASSEMBLY. FOR FINAL INSTALLATION, CONTACTS MUST BE ASSEMBLED INTO ALL INSERT HOLES. ALL UNUSED GROMMET HOLES MUST BE FILLED WITH APPROPRIATE SIZE SEALING PLUGS. CONTACTS AND SEALING PLUGS ARE SHIPPED UNASSEMBLED.

3. INSERT ASSEMBLY IS NOT REMOVABLE.

2. ALTERNATE ROTATIONS ARE OBTAINED BY ROTATING INDICATED KEYS, SIX POSITIONS ARE AVAILABLE.

1. FOR CONTACT ARRANGEMENT PATTERN, SEE APPLICABLE DRAWINGS PER L-218XX-HVXX.

NOTES:

THE USE OF THIS DOCUMENT IS UNLIMITED. HOWEVER, DOCUMENTS REFERENCED HEREON MAY CONTAIN LIMITED RIGHTS DATA.

PRELIMINARY DRAWING REVISION: P-2

FORMAT: C-U-E-I

FX-778410/419

SHEET 5 OF 5

REV.

-

SIZE C	CAGE CODE 77820	DOCUMENT NO. FX-778410/419	REV. -
SCALE: 3.5		REF: 91-684320/329	SHEET 5 OF 5

FX-778410/419 SHEET 5 OF 5

Eng PDM Information For Reference Only

REVISION

.

VERSION

2

D

C