



# MAX104/MAX106/MAX108 Evaluation Kits

## General Description

The MAX104/MAX106/MAX108 evaluation kits (EV kits) are designed to simplify evaluation of the devices' analog-to-digital converters (ADCs). Each EV kit contains all circuitry necessary to evaluate the dynamic performance of these ultra-high-speed converters, including the power-supply generation for the PECL termination voltage (PECLV<sub>TT</sub>). Since the design combines high-speed analog and digital circuitry, the board layout calls for special precautions and design features.

Connectors for the power supplies (V<sub>CCA</sub>/V<sub>CC1</sub>, V<sub>CCD</sub>, V<sub>CCO</sub>, V<sub>EE</sub>), SMA connectors for analog and clock inputs (VIN+, VIN-, CLK+, CLK-), and all digital PECL outputs simplify connection to the EV kit. The four-layer board layout (GETek™ material) is optimized for best dynamic performance of the MAX104 family.

The EV kits come with a MAX104/MAX106/MAX108 installed on the board with a heatsink attached for operation over the full commercial temperature range.

## Features

- ◆ 50Ω Clock and Analog Inputs Through SMA Coaxial Connectors
- ◆ ±250mV Input Signal Range
- ◆ Demultiplexed Differential PECL Outputs
- ◆ On-Board Generation of PECL Termination Voltage (PECLV<sub>TT</sub>)
- ◆ On-Board Generation of ECL Termination Voltage (ECLV<sub>TT</sub>)
- ◆ Separate Analog and Digital Power and Ground Connections with Optimized Four-Layer PCB
- ◆ Square-Pin Headers for Easy Connection of Logic Analyzer to Digital Outputs
- ◆ Fully Assembled and Tested

## Ordering Information

PART	TEMP. RANGE	PIN-PACKAGE	SAMPLING RATE
MAX104EVKIT	0°C to +70°C	192 ESBGA	1Gsp/s
MAX106EVKIT	0°C to +70°C	192 ESBGA	600Msp/s
MAX108EVKIT*	0°C to +70°C	192 ESBGA	1.5Gsp/s

\*Future product—contact factory for availability.

## Component List

DESIGNATION	QTY	DESCRIPTION
C1, C13, C20, C31, C40, C46, C48	7	10μF ±10%, 16V tantalum caps AVX TAJD106D016
C2, C7–C12, C14, C17, C18, C19, C21, C26–C30, C32, C41, C47, C49, C51–C59	30	0.01μF ±10% ceramic capacitors (0603)
C3–C6, C15, C16, C22–C25, C33–C37, C42–C45, C50	20	47pF ±10% ceramic capacitors (0402)
D1	1	1N5819 Schottky diode
R2	1	10kΩ potentiometer
R3, R4	2	Not populated; see text for description of reset input operation.

DESIGNATION	QTY	DESCRIPTION
R5–R38, R44–R47	38	49.9Ω ±1% resistors (0603)
R51, R53	2	243Ω ±1% resistors (0603)
R52, R54	2	158Ω ±1% resistors (0603)
J1–J10	10	SMA connectors (edge mounted)
JU3, JU6–JU9	5	3-pin headers
JU2, JU4, JU5, JUA0- to JUA7-, JUA0+ to JUA7+, JUP0- to JUP7-, JUP0+ to JUP7+, JUOR+, JUOR-, JUDR-, JUDR+, JURO-, JURO+	41	2-pin headers

GETek is trademark of GE Electromaterials.



Maxim Integrated Products 1

For free samples & the latest literature: <http://www.maxim-ic.com>, or phone 1-800-998-8800.  
For small orders, phone 1-800-835-8769.

Evaluate: MAX104/MAX106/MAX108

# MAX104/MAX106/MAX108 Evaluation Kits

## Component List (continued)

DESIGNATION	QTY	DESCRIPTION
None	4	Protective feet
V <sub>CCO</sub> , V <sub>CCD</sub> , GNDD, PECLV <sub>TT</sub> , GNDA, V <sub>CCA</sub> , V <sub>CCl</sub> , GNDI, V <sub>EE</sub> , ECLV <sub>TT</sub>	24	Test points
None	7	Shunts
None	1	Heatsink International Electronic Research Corp. BDN09-3CB/A01
U1	1	MAX104CHC, MAX106CHC, or MAX108CHC (192-contact ESBGA™)
U3, U4	2	LM2991S, low-dropout adjustable linear regulator
None	1	MAX104EVKIT circuit board
None	1	MAX104, MAX106, or MAX108 data sheet

## Quick Start

The EV kit is delivered fully assembled, tested, and sealed in an antistatic bag. To ensure proper operation, open the antistatic bag only at a static-safe work area and follow the instructions below. **Do not turn on the power supplies until all power connections to the EV kit are established.** Figure 1 shows a typical evaluation setup with differential analog inputs and single-ended sine-wave (CLK- is 50Ω reverse-terminated to GNDI) clock drive. Figure 2 shows a typical evaluation setup with single-ended analog inputs (VIN- is 50Ω reverse-terminated to GNDI) and a single-ended sine-wave clock drive.

- 1) Connect a -5V power supply capable of providing -250mA to the pad marked V<sub>EE</sub>. Connect the supply's ground to the GNDI pad. **Set the current limit to 500mA or less.**
- 2) Connect a +5V power supply capable of providing 600mA to the V<sub>CCl</sub> pad. Connect the supply's ground to the GNDI pad.
- 3) Connect a +5V power supply capable of providing 250mA to the V<sub>CCD</sub> pad. Connect the supply's ground to the GNDD pad.
- 4) Connect a +3.3V or +5V power supply capable of providing approximately 600mA to the V<sub>CCO</sub> pad. Connect the supply's ground to the GNDD pad.
- 5) Connect GNDI to GNDD at the power supplies.
- 6) Connect an RF source with low phase jitter, such as an HP8662A (up to 1.28GHz) or an HP8663A (up to 2.56GHz), to clock inputs CLK- and CLK+. For single-ended clock inputs, feed a +4dBm (500mV amplitude) power level from the signal generator into the CLK+ input and terminate the unused CLK- input with 50Ω to GNDI.
- 7) Connect a ±225mV (approximately -1dB below FS) sine-wave test signal to the analog inputs. Use VIN+ and VIN- through a balun if the test signal is differential, or either VIN+ or VIN- if the signal is single-ended (see the sections *Single-Ended Analog Inputs* and *Differential Analog Inputs* in the devices' data sheets). For best results, use a narrow band-pass filter designed for the frequency of interest to reduce the harmonic distortion from the signal generator.
- 8) Connect a logic analyzer, such as an HP16500C with an HP16517A plug-in card for monitoring all 16 output channels (8 channels for primary and 8 channels for auxiliary outputs) of the device.
- 9) Connect the logic analyzer clock to the DREADY+ output on the EV kit, and set the logic analyzer to trigger on the falling edge of the acquisition clock. Set the logic analyzer's threshold voltage to the V<sub>CCO</sub> supply voltage -1.3V. For example, if V<sub>CCO</sub> = +3.3V, the threshold voltage should be set to +2.0V.
- 10) Turn on the supplies and signal sources. Capture the digitized outputs from the ADC with the logic analyzer and transfer the digital record to a PC for data analysis.

ESBGA is a trademark of Amkor/Anam.

# MAX104/MAX106/MAX108 Evaluation Kits

Evaluate: MAX104/MAX106/MAX108

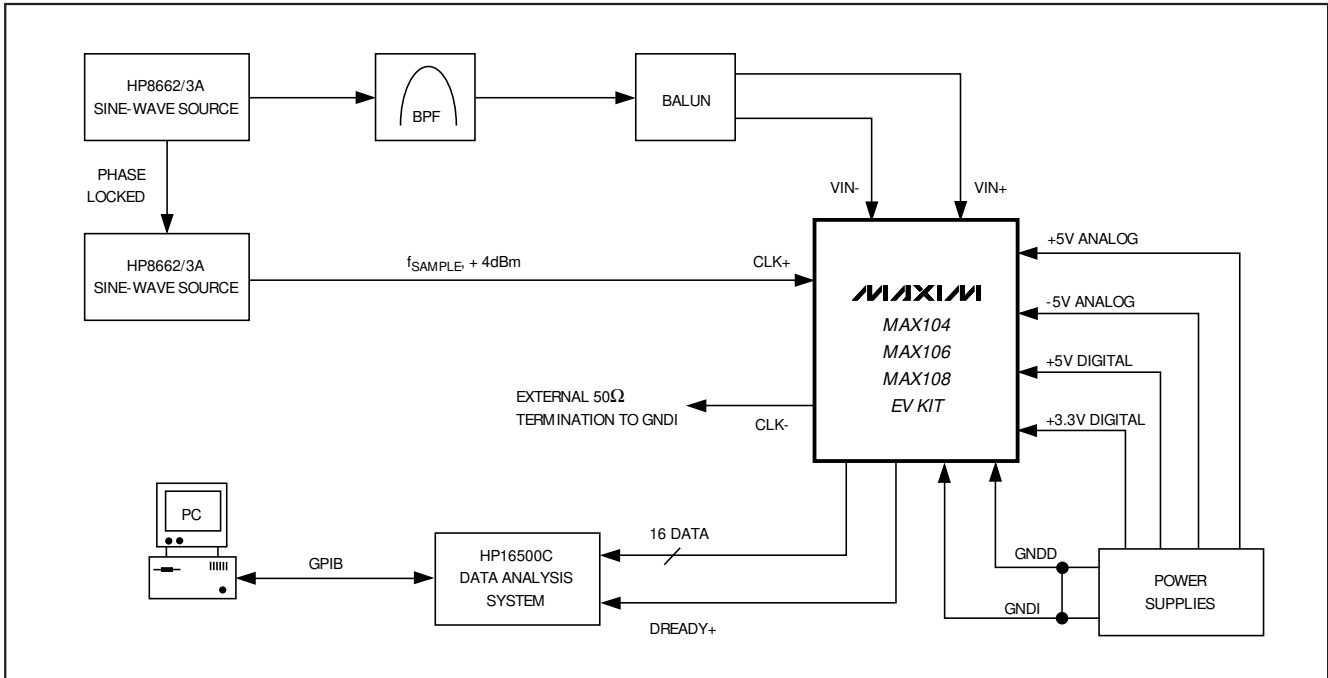

Figure 1. Typical Evaluation Setup with Differential Analog Inputs and Single-Ended Clock Drive

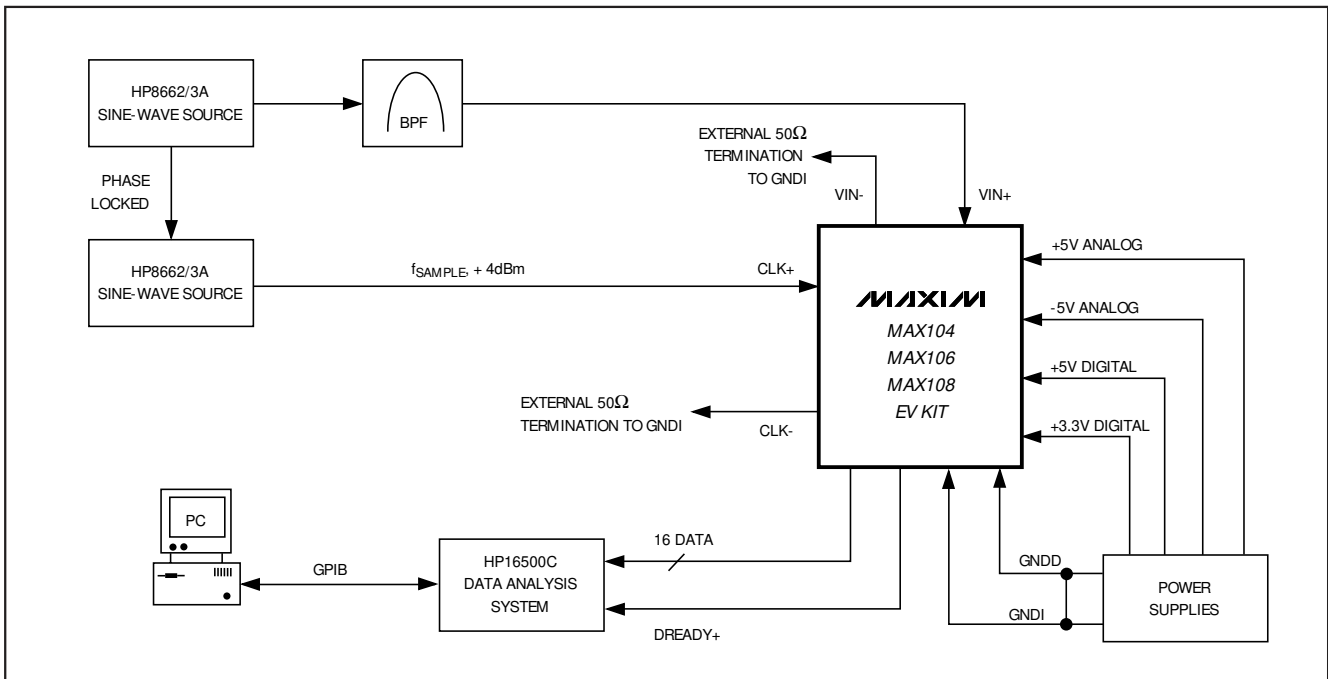

Figure 2. Typical Evaluation Setup with Single-Ended Analog Inputs and Single-Ended Clock Drive

# MAX104/MAX106/MAX108 Evaluation Kits

## Detailed Description

### Clock Input Requirements

The MAX104/MAX106/MAX108 feature clock inputs designed for either single-ended or differential operation with very flexible input drive requirements. Each clock input is terminated with an on-chip, laser-trimmed 50Ω resistor to CLKCOM (clock termination return). The traces from the SMA inputs to the high-speed data converter are 50Ω microstrip transmission lines.

The CLKCOM termination voltage may be connected anywhere between ground and -2V for compatibility with standard ECL drive levels. The side-launched SMA connectors for the clock signals are located at the lower left corner of the EV board and are labeled J3 (CLK+) and J4 (CLK-).

An on-board bias generator, located between the analog and clock inputs, creates a -2V termination voltage (ECLVTT) for operation with ECL clock sources. The voltage is generated by an LM2991 voltage regulator operated from the board's -5V VEE power supply. To enable this ECLVTT bias generator, first remove shorting jumper JU2, then move jumper JU3 into its ON position.

The voltage regulator has a shutdown control that requires a TTL logic-high level to enter the shutdown state. This logic level is derived from the +5V analog supply (VCC1). The EV kits are delivered with the ECLVTT bias generator turned off and CLKCOM tied to GNDI (JU2 installed).

**NOTE: If the regulator's shutdown logic level is not present (VCC1 on first) before the VEE supply is turned on, the regulator will momentarily turn on until the VCC1 supply is energized. If JU2 is installed, this will momentarily short the regulator's output to ground. The regulator is short-circuit protected so no damage will result. The regulator is further protected by limiting the VEE supply current to 500mA.**

### Single-Ended Clock Inputs (Sine-Wave Drive)

To obtain the lowest jitter clock drive, AC- or DC-couple a low-phase-noise sine-wave source into a single clock input. Clock amplitudes of up to 1V (2Vp-p or +10dBm) can be accommodated with CLKCOM connected to GNDI.

The dynamic performance of the data converter is essentially unaffected by clock-drive power levels from -10dBm to +10dBm (100mV to 1V clock signal amplitude). The dynamic performance specifications are measured with a single-ended clock drive of +4dBm (500mV clock signal amplitude). To avoid saturation of the input amplifier stage, limit the clock power level to a maximum of +10dBm.

### Differential Clock Inputs (ECL Drive)

The MAX104/MAX106/MAX108 clock inputs may also be driven with standard ground-referenced ECL logic levels by using the on-board ECLVTT -2V bias generator as described above. It is also possible to drive the clock inputs with positive supply referenced (PECL) levels if the clock inputs are AC-coupled. With AC-coupled clock inputs, the CLKCOM termination voltage should be grounded. Single-ended DC-coupled ECL drive is possible as well, if the undriven clock input is tied to the ECL VBB voltage (-1.3V nominal).

### Analog Input Requirements

The analog inputs to the ADC on the EV board are provided by two side-launch SMA connectors located on the middle left side of the EV kit. They are labeled J1 (VIN+) and J2 (VIN-). The analog inputs are terminated on-chip with precision laser-trimmed 50Ω NiCr resistors to GNDI. Although the analog (and clock) inputs are ESD protected, good ESD practices should always be observed. The traces from the SMA inputs to the device are 50Ω microstrip transmission lines. The analog inputs can be driven either single-ended or differential. Optimal performance is obtained with differential input drive due to reduction of even-order harmonic distortion. Table 1 represents single-ended input drive, and Table 2 displays differential input drive.

**Table 1. Input Setup and Output Code Results for Single-Ended Analog Inputs**

VIN+	VIN-	OVERRANGE BIT	OUTPUT CODE
+250mV	0V	1	11111111 (full scale)
+250mV - 1LSB	0V	0	11111111
0V	0V	0	01111111 toggles 10000000
-250mV + 1LSB	0V	0	00000001
-250mV	0V	0	00000000 (zero scale)

# MAX104/MAX106/MAX108 Evaluation Kits

**Table 2. Input Setup and Output Code Results for Differential Analog Inputs**

VIN+	VIN-	OVERRANGE BIT	OUTPUT CODE
+125mV	-125mV	1	11111111 (full scale)
+125mV - 0.5LSB	-125mV + 0.5LSB	0	11111111
0V	0V	0	01111111 toggles 10000000
-125mV + 0.5LSB	+125mV - 0.5LSB	0	00000001
-125mV	+125mV	0	00000000 (zero scale)

### Internal Reference

The MAX104 family features an on-chip +2.5V precision bandgap reference, which can be used by shorting jumper JU5 to connect REFOUT with REFIN. If required, REFOUT can also source up to 2.5mA to supply other peripheral circuitry.

To use an external reference, remove the shorting jumper on JU5 and connect the new reference voltage source to the REFIN side of JU5. Leave the REFOUT side of JU5 floating. Connect the ground of the external reference to GNDI on the EV kit. REFIN accepts an input voltage range of +2.3V to +2.7V.

**CAUTION: With an external reference connected, JU5 must not be installed at any time to avoid damaging the internal reference with the external reference supply.**

### Offset Adjust

The devices also provide a control input (VOSADJ) to eliminate any offset from additional preamplifiers driving the ADC. The VOSADJ control input is a self-biased voltage divider from the internal +2.5V precision reference. Under normal-use conditions, the control input is left floating.

The EV kits include a 10kΩ potentiometer that is biased from the ADC's +2.5V reference. The wiper of the potentiometer connects to the VOSADJ control input through JU4. To enable the offset-adjust function, install a shorting jumper on JU4 and adjust potentiometer R2 while observing the resulting offset in the reconstructed digital outputs. The offset-adjust potentiometer offers about ±5.5LSB of adjustment range. The EV kits are shipped from the factory without a shorting jumper installed on JU4.

### Primary and Auxiliary PECL Outputs

All PECL outputs on the EV kits are powered from the VCCO power supply, which may be operated from any voltage between +3.0V to +5.0V for flexible interfacing with either +3.3V or +5V systems. The nominal VCCO supply voltage is +3.3V.

The PECL outputs are standard open-emitter types and require external 50Ω termination resistors to the PECLVTT voltage for proper biasing. The termination resistors are located at the far end of each 50Ω microstrip transmission line, very close to the square pin headers for the logic analyzer interface. Every EV board is delivered with the PECL termination resistors installed on the back side of the board. Each output links to a 0.100 inch square 2-pin header to ease the connection to a high-speed logic analyzer such as Hewlett Packard's HP16500C.

To capture the digital data from the device in demultiplexed 1:2 format, each of the 16 channels from the logic analyzer is connected to the eight primary (P0 to P7) and eight auxiliary (A0 to A7) outputs. The ADC provides differential PECL outputs, but most logic analyzers (such as the HP16500C) have single-ended acquisition pods. Connect all single-ended logic analyzer pods to the same phase (either "+" or "-") of the PECL outputs.

### Data Ready (DREADY) Output

The clock pod from the logic analyzer should be connected to the DREADY+ output at JUDR+ on the EV kits. Since both the primary and auxiliary outputs change on the rising edge of DREADY+, set the logic analyzer to trigger on the falling edge. The DREADY and data outputs are internally time-aligned, which places the falling edge of DREADY+ in the approximate center of the valid data window, resulting in the maximum setup and hold time for the logic analyzer. Set the logic analyzer's threshold voltage to VCCO - 1.3V. For example, if VCCO is +3.3V, the threshold voltage should be set to +2.0V. The sample offset (trigger delay) of the logic analyzer should be set to 0ps under these conditions.

It is also possible to use the DREADY- output for the acquisition clock. Under this condition, set the logic analyzer to trigger on the rising edge of the clock. Table 3 summarizes the digital outputs and their functions.

# MAX104/MAX106/MAX108 Evaluation Kits

**Table 3. PECL Outputs and Functions**

PECL OUTPUT SIGNALS	EV KIT JUMPER LOCATION	FUNCTION
P0+ to P7+, P0- to P7-	JUP0+ to JUP7+, JUP0- to JUP7-	Primary Port Differential Outputs from LSB to MSB. A "+" indicates the true value; a "-" denotes the complementary outputs.
A0+ to A7+, A0- to A7-	JUA0+ to JUA7+, JUA0- to JUA7-	Auxiliary Port Differential Outputs from LSB to MSB. A "+" indicates the true value; a "-" denotes the complementary outputs.
OR+, OR-	JUOR+, JUOR-	Overrange's True and Complementary Outputs.
DREADY+, DREADY-	JUDR+, JUDR-	Data-Ready PECL Output Latch Clock. Output data changes on the rising edge of DREADY+.
RSTIN+, RSTIN-	J5, J6 (SMA connectors)	Demux Reset Input Signals. Resets the internal demux when asserted.
RSTOUT+, RSTOUT-	JURO+, JURO-	Reset Outputs—for resetting additional external demux devices.

### Demultiplexer Settings

#### Demultiplexed DIV2 Mode

This mode reduces the output data rate to one-half the sample clock rate. The demultiplexed outputs are presented in dual 8-bit format with two consecutive samples in the primary and auxiliary output ports on the rising edge of the data ready clock. To activate this mode, jumpers JU7 (DEMUXEN), JU8 (AUXEN2), and JU9 (AUXEN1) have to be in the ON position, and DIVSELECT (JU6) must be set to position 2.

**NOTE:** Each EV kit is shipped with jumpers JU7, JU8, and JU9 installed in the ON position and JU6 set to 2.

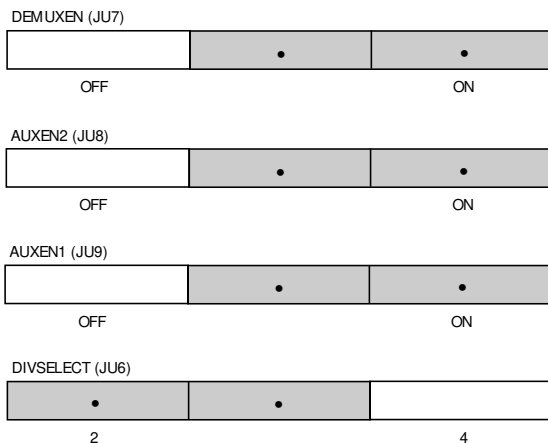

#### Non-Demultiplexed DIV1 Mode

It is also possible to operate the ADC in a non-demultiplexed mode. In this mode, the internal demultiplexer is disabled and the sampled data is presented to the primary output port only. To consume less power, the auxiliary port can be shut down by two separate inputs (AUXEN1 and AUXEN2). To enter this mode, place jumpers JU7 (DEMUXEN), JU8 (AUXEN2), and JU9 (AUXEN1) in the OFF position. The position of the DIVSELECT (JU6) jumper is a don't care. To save additional power, remove all the 50Ω pull-down resistors (R5–R20) on the auxiliary output port. It is not necessary to remove the resistors; however, both the true and complementary PECL outputs will pull up to the V<sub>OH</sub> level.

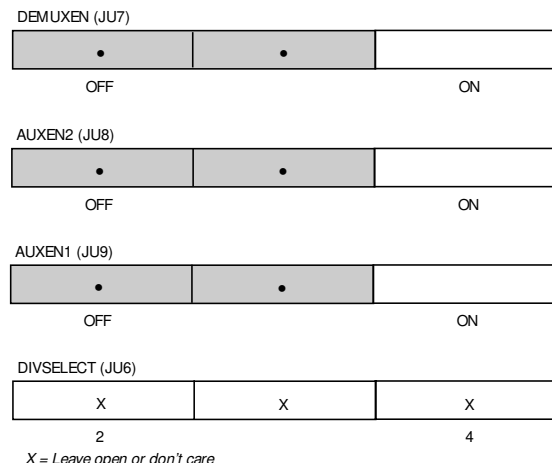

# MAX104/MAX106/MAX108 Evaluation Kits

Evaluate: MAX104/MAX106/MAX108

## Decimation DIV4 Mode

In this special decimated, demultiplexed output mode, the ADC discards every other input sample and outputs data at one-quarter the input sampling rate. This mode is useful for system debugging at the resulting slower output data rates, and may be required to capture data successfully when testing the MAX108. To activate the EV board's DIV4 mode, jumpers JU7 (DEMUXEN), JU8 (AUXEN2), and JU9 (AUXEN1) have to be in the ON position, and DIVSEL has to be in position 4. Since every other sample at the input is discarded, the converter's effective sample rate will be  $f_{SAMPLE}/2$ .

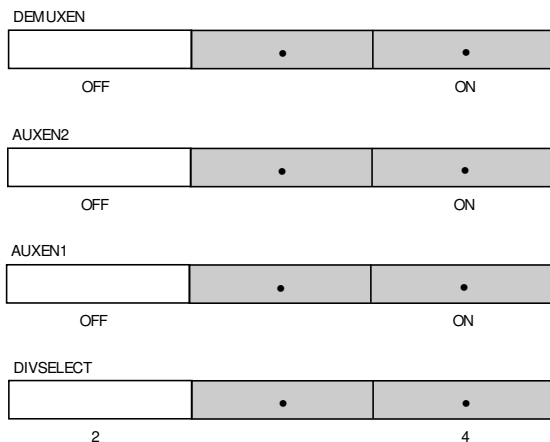

## Ovrrange Operation

A single differential PECL overrange output bit (OR+, OR-) is provided for both primary and auxiliary demultiplexed outputs. The operation of the overrange bit depends on the status of the internal demultiplexer. In demultiplexed DIV2 mode and decimation DIV4 mode, the OR bit will flag an overrange condition if either the primary or auxiliary port contains an overranged sample (Table 4). In non-demultiplexed DIV1 mode, the OR port will flag an overrange condition only when the primary output port contains an overranged sample.

## Reset Operation Requirements

A detailed description of the reset circuitry and its operation is located in each device's data sheet. To use the reset input function, install two 50Ω pull-down resistors at positions R3 and R4 on the back side of the EV board. These resistors are connected to the on-board PECL<sub>VTT</sub> termination generator. The RSTIN logic levels are compatible with standard PECL levels referenced from the V<sub>CCO</sub> power supply.

**Table 4. Selection Table for Demultiplexer Operation**

DEMUXEN	DIVSELECT	DEMUX MODE	OVERRRANGE BIT OUTPUT MODE
OFF	X	DIV1	Only primary port active (auxiliary port off)
ON	2	DIV2	Primary OR auxiliary port
ON	4	DIV4	Primary OR auxiliary port

X = Don't care

The signals associated with the demultiplexer reset operation and the control of this section are listed in Table 5. Consult the data sheet for a more detailed description of the demultiplexer reset function, including timing diagrams.

## Reset Inputs

The reset circuitry accepts differential PECL inputs referenced to the same V<sub>CCO</sub> power supply that powers the ADC's PECL outputs. The reset input side-launched SMA connectors are located at the lower left side of the EV kits and are labeled RSTIN+ and RSTIN-.

For applications that do not require a synchronizing reset, the reset inputs must be left open and resistors R3 and R4 removed. In this case, they will self-bias to a proper level with internal 50kΩ resistors and a 20μA current source. This combination creates a -1V voltage difference between RSTIN+ and RSTIN- to disable the internal reset circuitry. When driven with PECL logic levels terminated with 50Ω to V<sub>CCO</sub> - 2V, the internal biasing network can easily be overdriven. The EV kits are shipped with these resistor positions open to allow the internal self-bias circuitry to disable the reset control input.

**NOTE: Do not install the 50Ω RSTIN termination resistors R3 and R4 unless the RSTIN input is driven with valid PECL logic levels. If the RSTIN inputs are open circuited with the 50Ω resistors installed, intermittent resetting of the internal demultiplexer will occur and unpredictable operation will result.**

# MAX104/MAX106/MAX108 Evaluation Kits

**Table 5. Demultiplexer Operation and Reset Control Signals**

SIGNAL NAME	EV KIT JUMPER LOCATION	FUNCTION
CLK+, CLK-	J3, J4	Master ADC Timing Signal. The ADC samples on the rising edge of CLK+.
DREADY+, DREADY-	JUDR+, JUDR-	Data-Ready PECL Output. Output data changes on the rising edge of DREADY+.
RSTIN+, RSTIN-	J5, J6	Demux Reset Input Signal. Resets the internal demux when asserted.
RSTOUT+, RSTOUT-	JURO+, JURO-	Reset Output—for resetting additional external demux devices.

**Table 6. Power-Supply and Ground Requirements and Location**

POWER SUPPLY	EV KIT JUMPER LOCATION	GROUND REFERENCE	EV KIT JUMPER LOCATION
$V_{EE} = -5V$	J17	GNDI	J16
$V_{CCA} = V_{CCL} = +5V$	J13, J15	GNDA/GNDI	J14, J16
$V_{CCD} = +5V$	J11	GNDD	J12
$V_{CCO} = +3.0V$ to $+5V$	J18	GNDD	J12

### Reset Outputs

With a single device, no synchronizing reset is required since the order of the samples in the output ports is unchanged regardless of the phase of the DREADY (DREADY+, DREADY-) clock (as described in the data sheets). DREADY+ (jumper JUDR+) and DREADY- (jumper JUDR-) can be found in the middle of the PECL output arc in the right center of the EV board.

On the EV kits, the reset output 2-pin headers for RSTOUT+ (jumper JURO+) and RSTOUT- (jumper JURO-) are located above the reset input SMA connectors on the lower left side of the board.

### Power Supplies

The EV kits feature separate analog and digital power supplies and grounds for best dynamic performance. The power-supply connectors are located at the top of the board and require the power supplies listed in Table 6.

To simplify use of the EV kits and reduce the number of power sources required to drive the EV board,  $V_{CCA}$  and  $V_{CCL}$ , as well as GNDA and GNDI, are connected together by shorting straps SP1 and SP2. To separate the supplies, cut the traces at SP1 and SP2. Be sure to observe the absolute maximum voltage difference of  $\pm 0.3V$  between the supplies if separate supplies are used. This may require back-to-back Schottky diodes between  $V_{CCA}$  and  $V_{CCL}$  to prevent violation of the absolute maximum ratings during power-up/down.

The EV kits are tested with the  $V_{CCA}$  and  $V_{CCL}$  supplies shorted by SP1 and SP2. There is no measurable difference in the parts' dynamic performance with the supplies separated, therefore Maxim recommends leaving the supplies connected together.

**CAUTION: There are no connections between GNDA/GNDI and GNDD on the EV kits. These grounds must be referenced together at the power supply to the board, or damage to the device may result!**

Referencing analog (GNDA/GNDI) and digital (GNDD) grounds together at a single point avoids ground loops and reduces noise pickup from the digital signals or power lines.

To avoid a possible latchup condition when disassembling an application, a high-speed Schottky diode (D1, 1N5819) was added between  $V_{EE}$  and GNDI. This diode prevents the substrate (which is connected to  $V_{EE}$ ) from forward biasing and possibly causing a latchup condition when the  $V_{EE}$  connector is opened.

### Board Layout

Each EV kit is a four-layer board design, optimized for high-speed signals. The board is constructed from low-loss GETek core material, which has a relative dielectric constant of 3.9 ( $\epsilon_r = 3.9$ ). The GETek material used for the EV board offers improved high-frequency and thermal properties over standard FR4 board material. All high-speed signals are routed with 50 $\Omega$  microstrip



# MAX104/MAX106/MAX108 Evaluation Kits

Evaluate: MAX104/MAX106/MAX108

**Table 7. EV Kit PCB Layers**

LAYER	DESCRIPTION
Layer I, top layer	Components, jumpers, connectors, test pads, V <sub>CCO</sub> , GNDD, GNDI, analog 50Ω microstrip lines, de-embedding fixtures
Layer II, ground plane	Ground for analog 50Ω microstrips, GNDA, GNDD, GNDI, V <sub>CCD</sub>
Layer III, power plane	VEE, PECLV <sub>TT</sub> (V <sub>CCO</sub> - 2V), GNDD
Layer IV, bottom layer	V <sub>CCA</sub> , V <sub>CCO</sub> , GNDI, digital 50Ω microstrip lines, 50Ω termination resistors

transmission lines. The line width for 50Ω microstrip is 18 mils with a ground plane height of 10 mils, which is a standard GETek core thickness. Figure 3 shows a cross-section of the EV kit layer profile.

The board also features a de-embedding fixture formed from two lengths of microstrip transmission line connected between SMA connectors J9-10 and J7-8, located on the right edge of the board. The 1.50-inch line length difference between the two paths exactly matches the line length of the microstrip connecting the analog inputs. By measuring the power-loss difference between the two paths at the frequency of interest, it is possible to estimate the attenuation of the analog inputs caused by PCB losses. Figure 4 shows the measured attenuation vs. frequency for the microstrip lines connecting the analog inputs.

### Special Layout Considerations

A special effort was made in the board layout to separate the analog and digital portions of the circuit. 50Ω microstrip transmission lines are used for the analog and clock inputs as well as for the high-speed PECL digital outputs. The analog and clock transmission lines are formed on the top side of the board, while the digital transmission lines are located on the back side of the board. This reduces coupling of the high-speed digital outputs to the analog inputs. The analog and clock inputs provide on-chip, laser-trimmed 50Ω termination resistors for the best VSWR performance.

Wherever large ground or power planes are used, care was taken to ensure that the analog planes were not overlapping with any digital planes. This eliminates the possibility of capacitively coupling digital noise through the circuit board to sensitive analog areas.

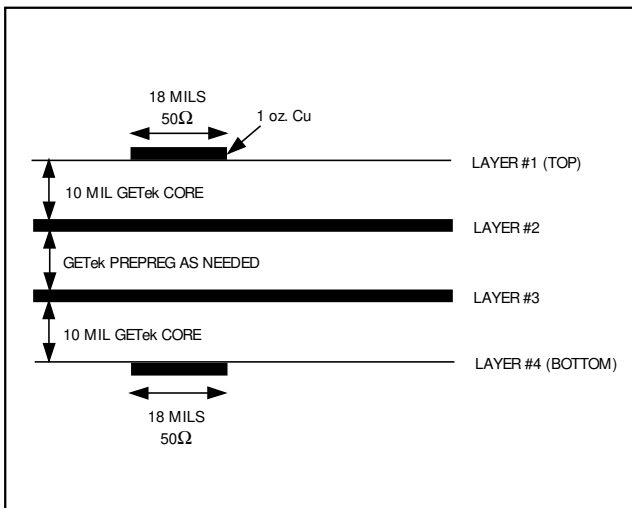

Figure 3. EV Kit Layer Profile for 50Ω Microstrip Design

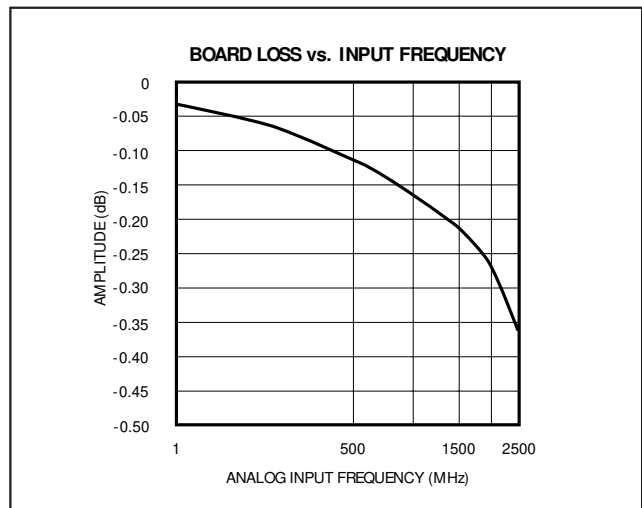

Figure 4. Analog Input Attenuation from PCB Losses

## MAX104/MAX106/MAX108 Evaluation Kits

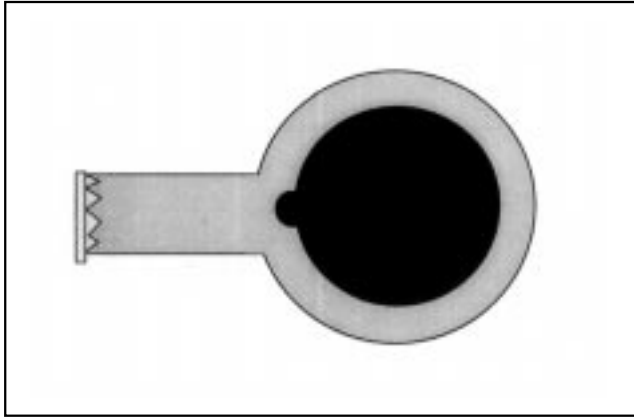

Figure 5a. BGA PCB Pad Designs (SMD Pad)

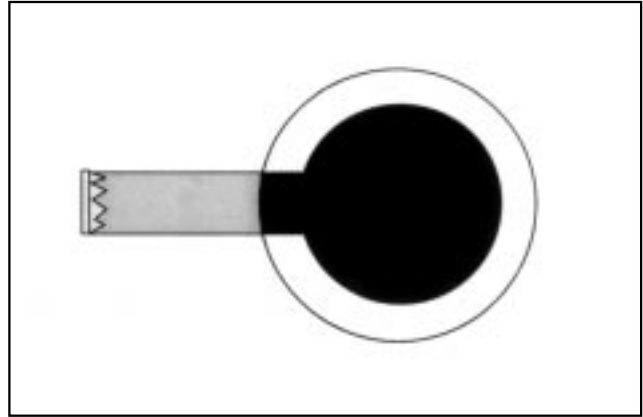

Figure 5b. BGA PCB Pad Designs (Non-SMD Pad)

All differential digital outputs are properly terminated with 50Ω termination resistors on both phases of the output, even though most logic analyzers are single ended. By terminating both sides of the differential outputs, the AC current in the V<sub>CCO</sub> and G<sub>NDD</sub> supplies is reduced. This also reduces coupling of the ADC outputs back to the analog inputs and preserves the excellent SNR performance of the converter.

The PECL digital outputs are arranged in an arc to match the line lengths between the ADC outputs and the logic analyzer connectors. The lengths of the 50Ω microstrip lines are matched to within 0.050 inch to minimize layout-dependent data skew between the bits. The propagation delay on the EV board is about 134ps per inch.

### ESBGA Device Pad Design

An excellent reference on the assembly and design of PCBs with BGA devices is “*Application Notes on Surface Mount Assembly of Amkor/Anam BGA Packages*.” This publication is available from Amkor/Anam, 1900 S. Price Road, Chandler AZ, 85248, phone: (602) 821-5000.

As described in the above applications note, there are two possibilities for defining PCB pads for mounting BGA devices: solder mask defined (SMD) and nonsolder mask defined (non-SMD, copper defined). The EV kits’ design employs nonsolder mask defined pads. Figure 5 shows the layout of each of these pad types.

The non-SMD (Figure 5b) pad has a solder-mask opening that is larger than the copper land area. This means that the size of the mounting pad is controlled by the

copper etch quality control. The SMD pad (Figure 5a) has a solder-mask opening that is smaller than the copper land area. This means that the solder-mask alignment and etch quality will control the pad dimensions.

Since the edges of the copper do not need to extend under the solder mask as with the SMD pad, the pad can either be made larger or can provide more line routing space between adjacent pads. There is room to route a single 50Ω microstrip trace (18 mils wide) between the BGA mounting pads on the EV kits. The copper land diameter is 25 mils, while the solder mask opening is 30 mils.

### Die Temperature Measurement

It is possible to determine the die temperature of the ADC under normal operating conditions by observing the currents I<sub>CONST</sub> and I<sub>PTAT</sub>. These are two nominally 100μA currents designed to be equal at 27°C. The currents are derived from the internal precision +2.5V bandgap reference of the ADC. Their test pads (J21 and J22) are labeled I<sub>CONST</sub> and I<sub>PTAT</sub> and are located just above the analog inputs.

The simplest method of determining die temperature is to measure each current with an ammeter referenced to GNDI, as described in the data sheets. The die temperature in °C is then calculated by the expression:

$$T_{DIE} = 300 \cdot \left( \frac{I_{PTAT}}{I_{CONST}} \right) - 273$$

# MAX104/MAX106/MAX108 Evaluation Kits

Evaluate: MAX104/MAX106/MAX108

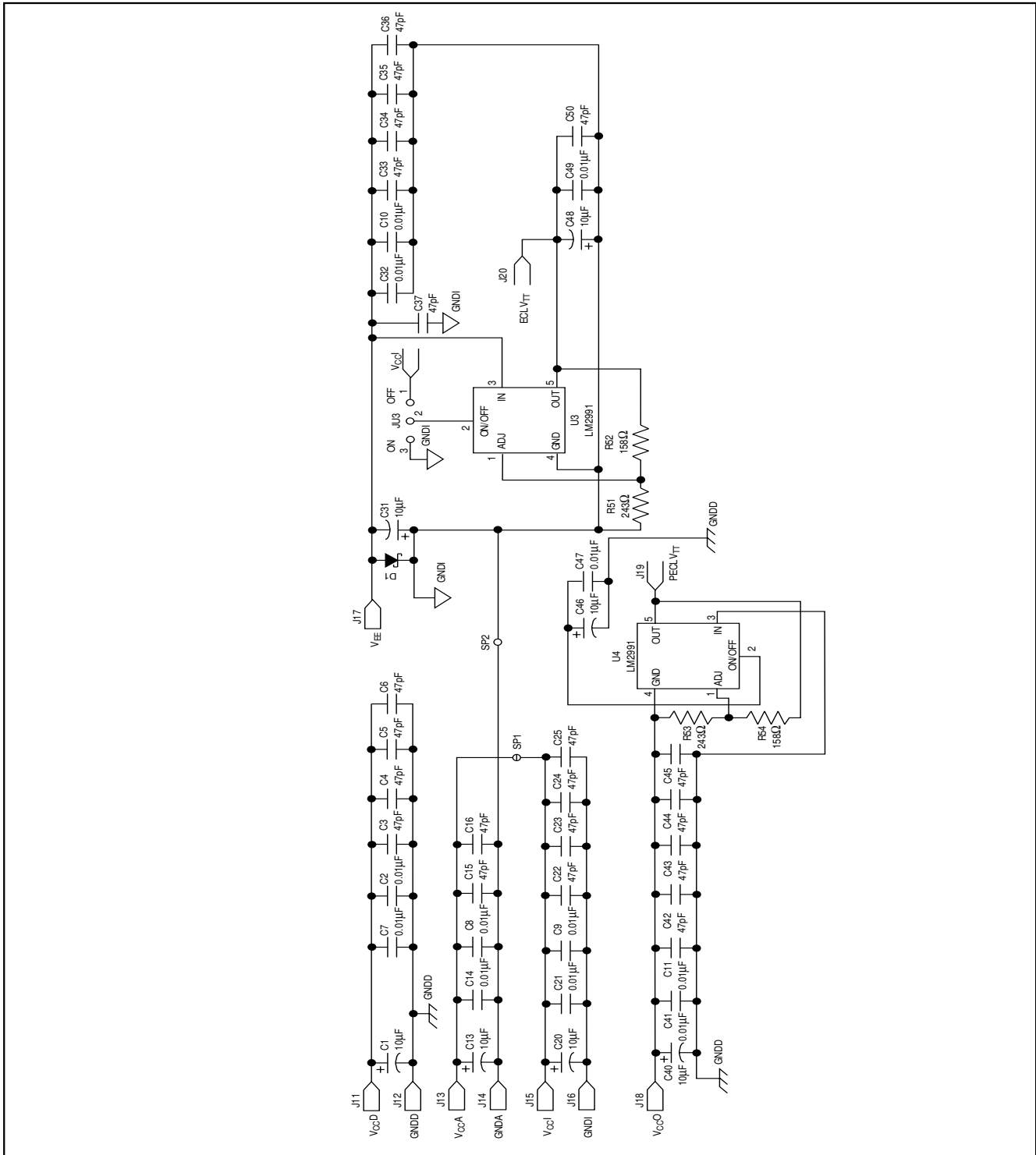

Figure 6. MAX104/MAX106/MAX108 EV Kits Schematic

# MAX104/MAX106/MAX108 Evaluation Kits

Evaluate: MAX104/MAX106/MAX108

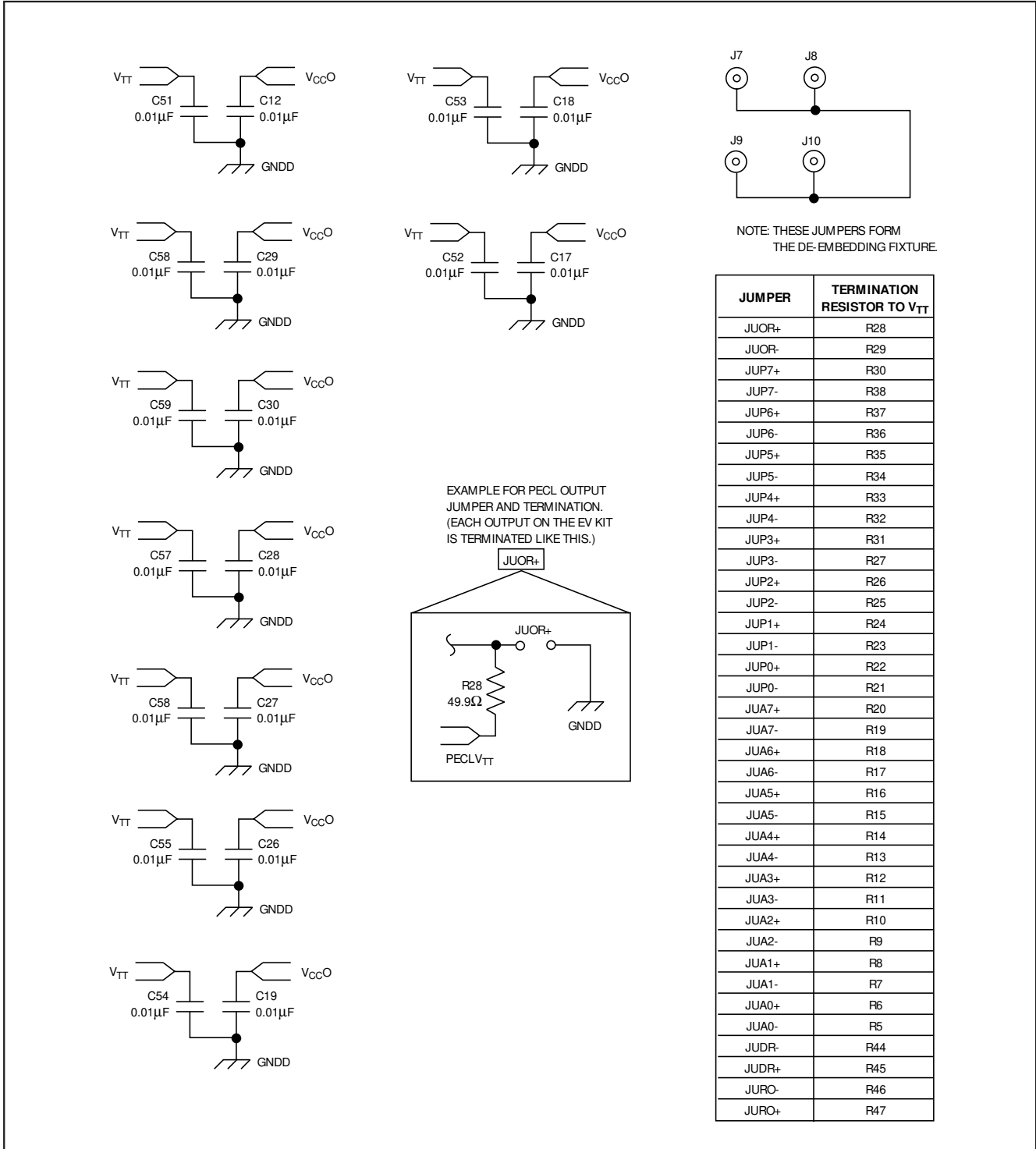

Figure 6. MAX104/MAX106/MAX108 EV Kits Schematic (continued)

# MAX104/MAX106/MAX108 Evaluation Kits

Evaluate: MAX104/MAX106/MAX108

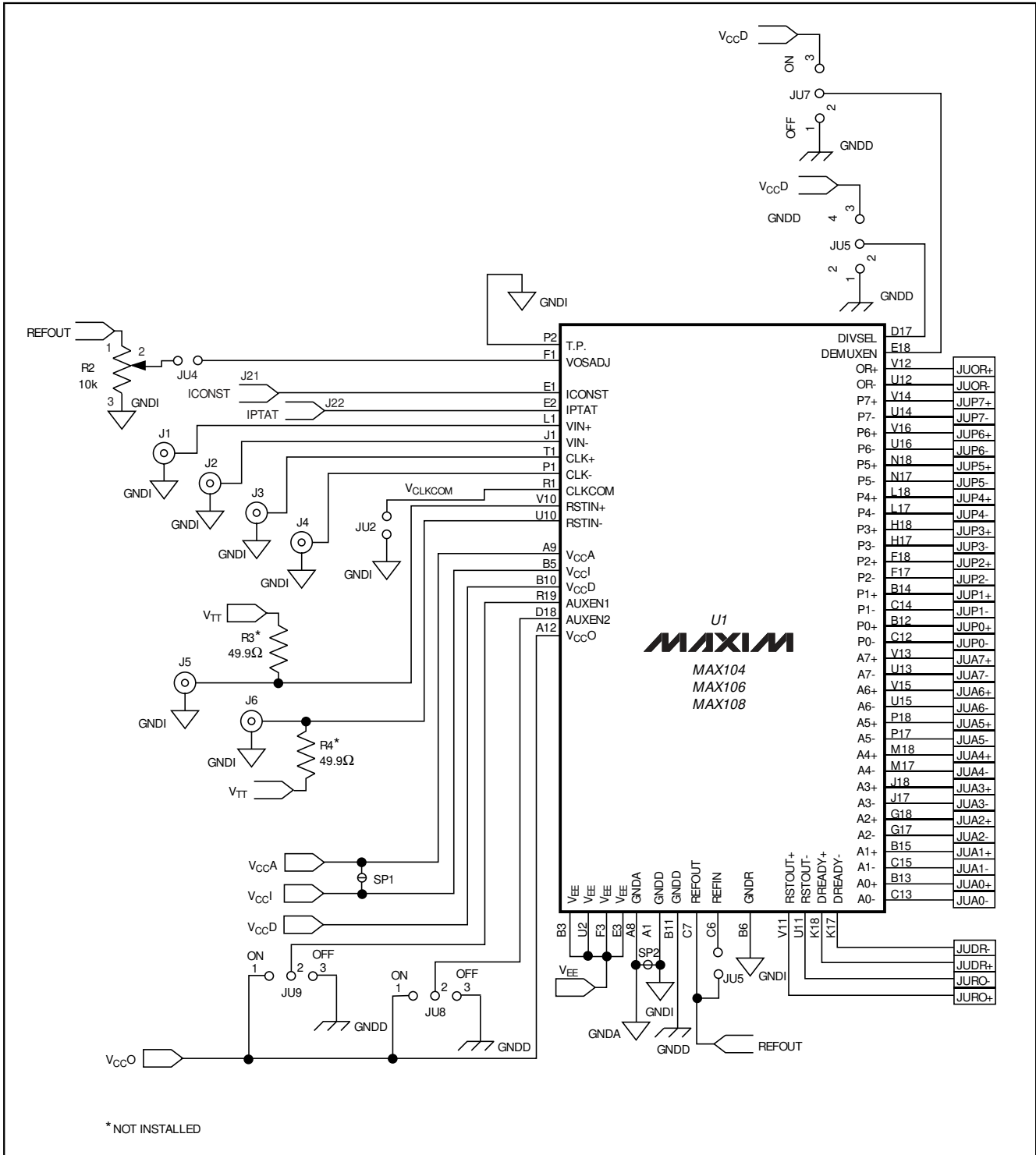

Figure 6. MAX104/MAX106/MAX108 EV Kits Schematic (continued)



# MAX104/MAX106/MAX108 Evaluation Kits

Evaluate: MAX104/MAX106/MAX108

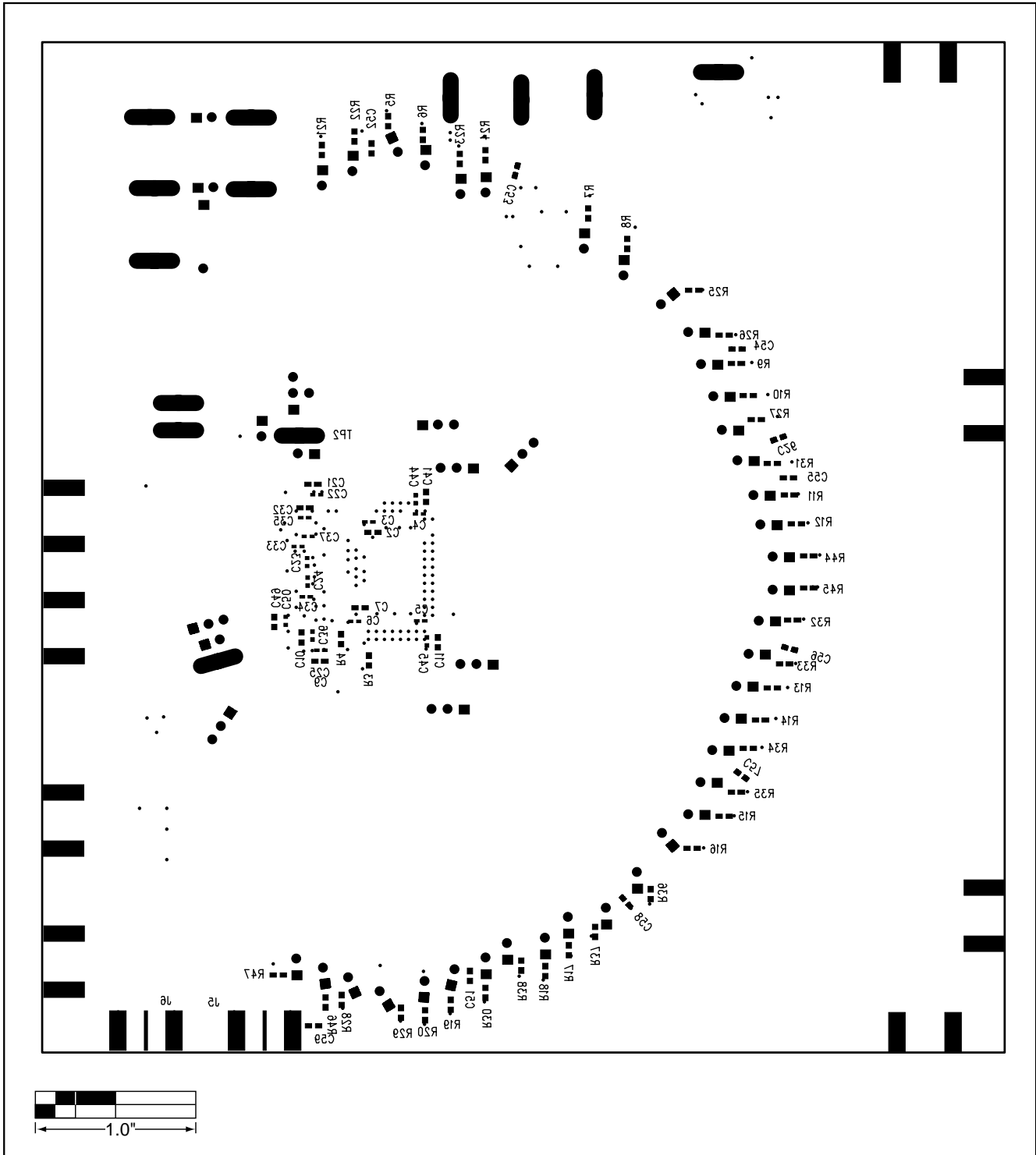

Figure 8. MAX104/MAX106/MAX108 EV Kits Component Placement Guide—Solder Side (Layer IV)

# MAX104/MAX106/MAX108 Evaluation Kits

Evaluate: MAX104/MAX106/MAX108

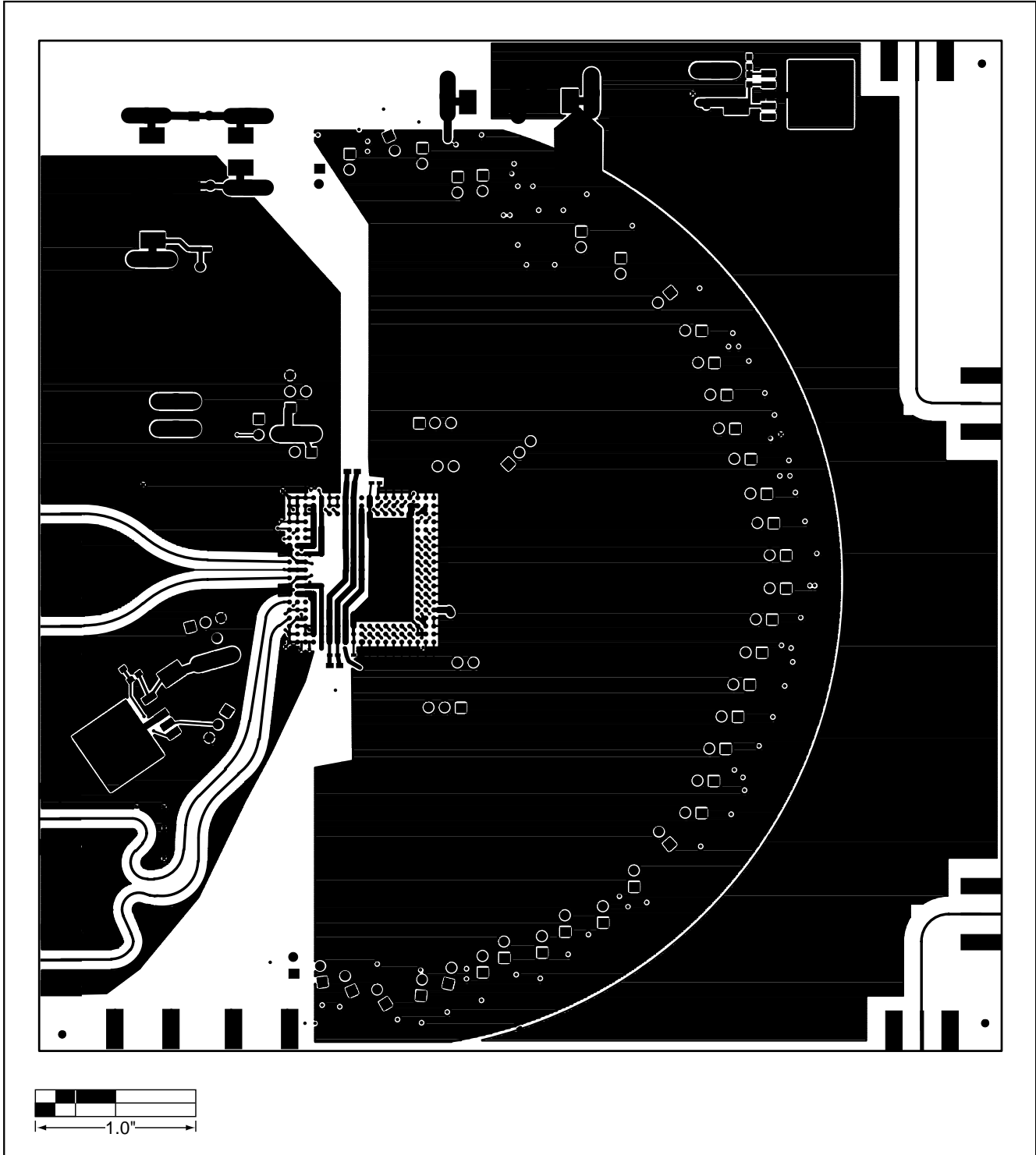

Figure 9. MAX104/MAX106/MAX108 EV Kits PC Board Layout—Component Side (Layer 1)



# MAX104/MAX106/MAX108 Evaluation Kits

Evaluate: MAX104/MAX106/MAX108

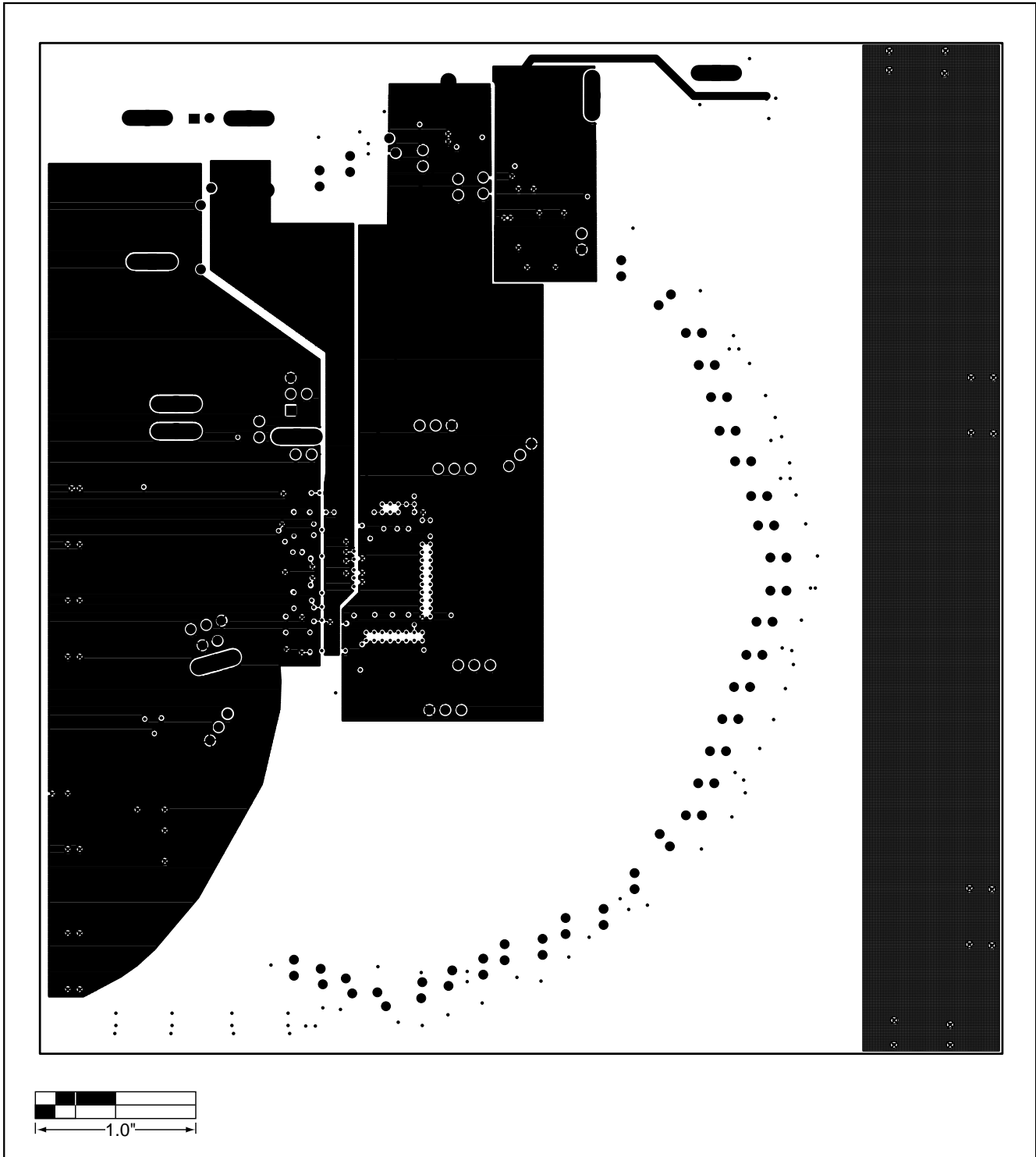

Figure 10. MAX104/MAX106/MAX108 EV Kits PC Board Layout—GND Plane (Layer II)

# MAX104/MAX106/MAX108 Evaluation Kits

Evaluate: MAX104/MAX106/MAX108

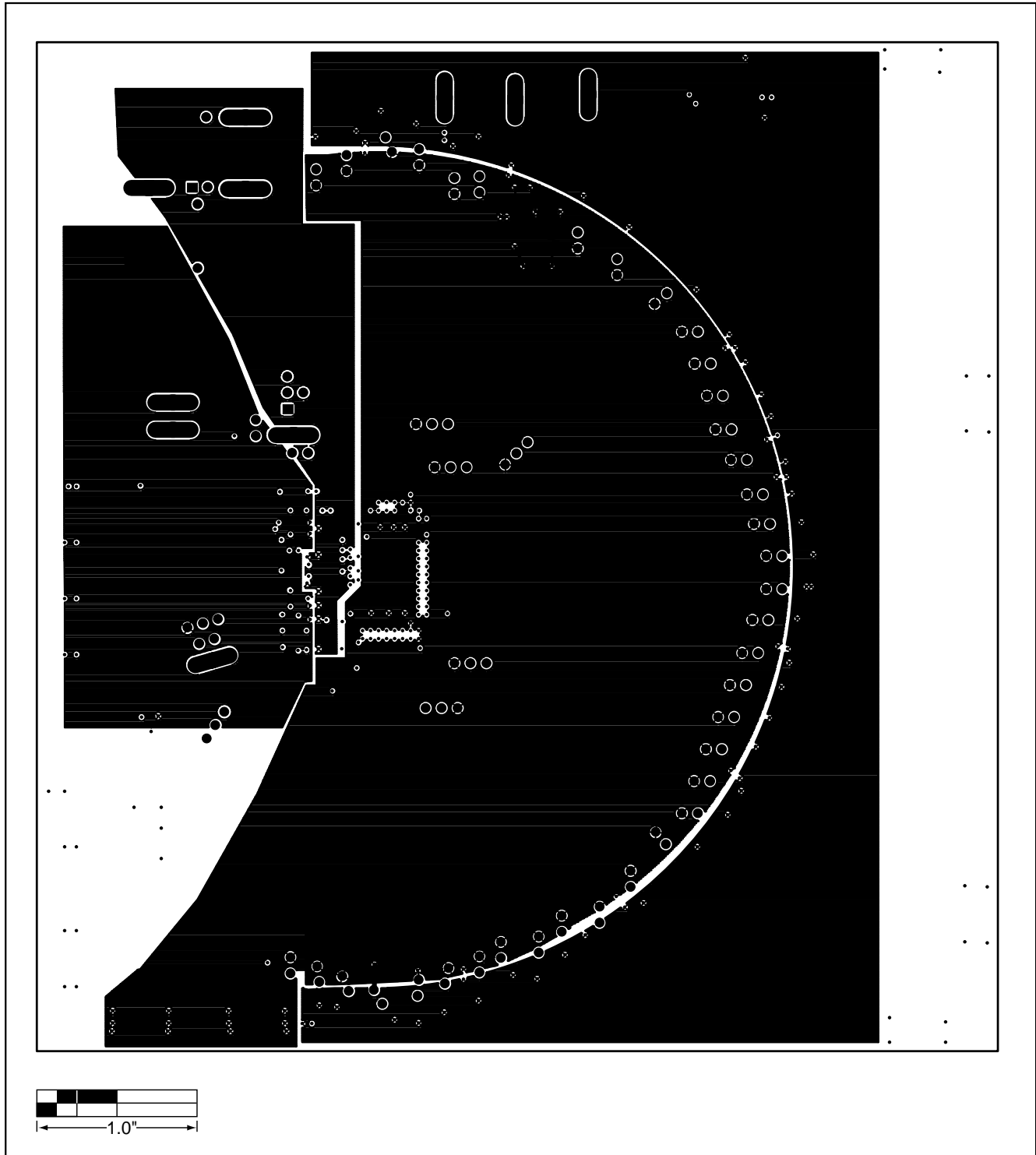

Figure 11. MAX104/MAX106/MAX108 EV Kits PC Board Layout—Power Plane (Layer III)

# MAX104/MAX106/MAX108 Evaluation Kits

Evaluate: MAX104/MAX106/MAX108

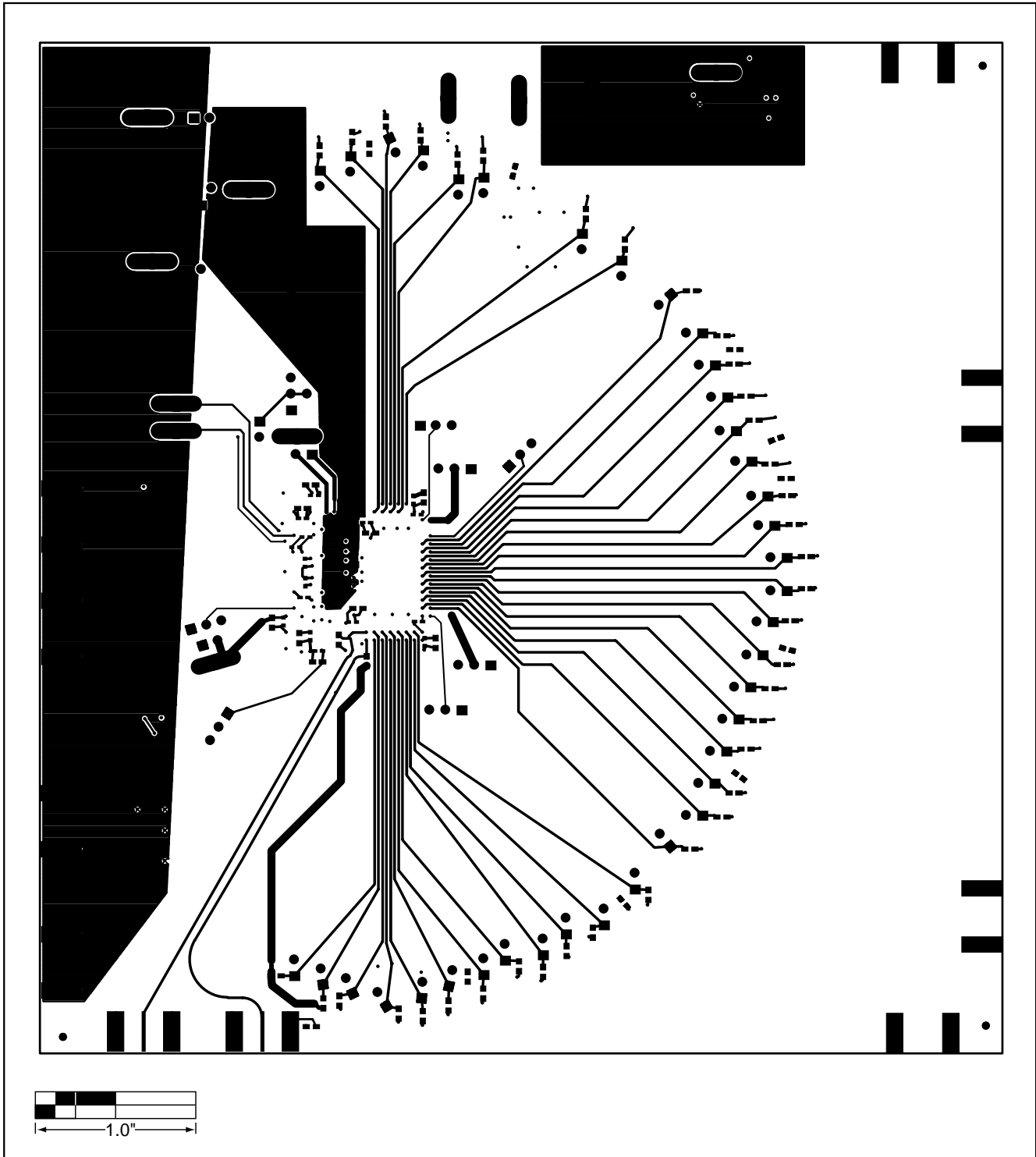

Figure 12. MAX104/MAX106/MAX108 EV Kits PC Board Layout—Solder Side (Layer IV)

# MAX104/MAX106/MAX108 Evaluation Kits

## NOTES

**Evaluates: MAX104/MAX106/MAX108**

*Maxim cannot assume responsibility for use of any circuitry other than circuitry entirely embodied in a Maxim product. No circuit patent licenses are implied. Maxim reserves the right to change the circuitry and specifications without notice at any time.*

20 \_\_\_\_\_ **Maxim Integrated Products, 120 San Gabriel Drive, Sunnyvale, CA 94086 408-737-7600**