

## 500mW, 2.4V - 75V Zener Diode

### FEATURES

- Wide Zener voltage range selection: 2.4V to 75V
- $V_Z$  Tolerance selection of  $\pm 2\%$
- Hermetically sealed glass
- RoHS Compliant

### APPLICATIONS

- Low voltage stabilizers or voltage references
- Adapters
- Lighting application
- On-board DC/DC converter

### MECHANICAL DATA

- Case: DO-35
- Terminal: Pure tin plated leads, solderable per J-STD-002
- Polarity: Indicated by cathode band
- Weight: 101.67mg (approximately)

KEY PARAMETERS		
PARAMETER	VALUE	UNIT
$V_Z$	2.4 - 75	V
Test current $I_{ZT}$	2 - 5	mA
$P_D$	500	mW
$V_F$ at $I_F = 100\text{mA}$	1.5	V
$T_{J\text{MAX}}$	175	$^{\circ}\text{C}$
Package	DO-35	
Configuration	Single die	



DO-35



ABSOLUTE MAXIMUM RATINGS ( $T_A = 25^{\circ}\text{C}$ unless otherwise noted)			
PARAMETER	SYMBOL	VALUE	UNIT
Power dissipation	$P_D$	500	mW
Forward voltage @ $I_F = 100\text{mA}$	$V_F$	1.5	V
Junction temperature range	$T_J$	-55 to +175	$^{\circ}\text{C}$
Storage temperature range	$T_{STG}$	-55 to +175	$^{\circ}\text{C}$

**ELECTRICAL SPECIFICATIONS** ( $T_A = 25^\circ\text{C}$  unless otherwise noted)

PART NUMBER	MARKING CODE	ZENER VOLTAGE			TEST CURRENT	REGULAR IMPEDANCE <sup>(1)</sup>		TEST CURRENT	LEAKAGE CURRENT	
		$V_Z @ I_Z^{(1)}$			$I_{ZT}$	$Z_{ZT} @ I_{ZT}$	$Z_{ZK} @ I_{ZK}$	$I_{ZK}$	$V_Z @ I_{ZT}$	
		V			mA	$\Omega$	$\Omega$	mA	V	mA
		Min	Nom	Max		Max	Max		Max	
BZX79B2V4	BZX79B2V4	2.35	2.40	2.45	5	100	600	1.0	100	1.0
BZX79B2V7	BZX79B2V7	2.65	2.70	2.75	5	100	600	1.0	75	1.0
BZX79B3V0	BZX79B3V0	2.94	3.00	3.06	5	95	600	1.0	50	1.0
BZX79B3V3	BZX79B3V3	3.23	3.30	3.37	5	95	600	1.0	25	1.0
BZX79B3V6	BZX79B3V6	3.53	3.60	3.67	5	90	600	1.0	15	1.0
BZX79B3V9	BZX79B3V9	3.82	3.90	3.98	5	90	600	1.0	10	1.0
BZX79B4V3	BZX79B4V3	4.21	4.30	4.39	5	90	600	1.0	5	1.0
BZX79B4V7	BZX79B4V7	4.61	4.70	4.79	5	80	500	1.0	3.0	2.0
BZX79B5V1	BZX79B5V1	5.00	5.10	5.2	5	60	480	1.0	2.0	2.0
BZX79B5V6	BZX79B5V6	5.49	5.60	5.71	5	40	400	1.0	1.0	2.0
BZX79B6V2	BZX79B6V2	6.08	6.20	6.32	5	10	150	1.0	3.0	4.0
BZX79B6V8	BZX79B6V8	6.66	6.80	6.94	5	15	80	1.0	2.0	4.0
BZX79B7V5	BZX79B7V5	7.35	7.50	7.65	5	15	80	1.0	1.0	5.0
BZX79B8V2	BZX79B8V2	8.04	8.20	8.36	5	15	80	1.0	0.7	5.0
BZX79B9V1	BZX79B9V1	8.92	9.10	9.28	5	15	100	1.0	0.5	6.0
BZX79B10	BZX79B10	9.80	10.00	10.2	5	20	150	1.0	0.2	7.0
BZX79B11	BZX79B11	10.78	11.00	11.22	5	20	150	1.0	0.1	8.0
BZX79B12	BZX79B12	11.76	12.00	12.24	5	25	150	1.0	0.1	8.0
BZX79B13	BZX79B13	12.74	13.00	13.26	5	30	170	1.0	0.1	8.0
BZX79B15	BZX79B15	14.70	15.00	15.30	5	30	200	1.0	0.05	10.5
BZX79B16	BZX79B16	15.68	16.00	16.32	5	40	200	1.0	0.05	11.2
BZX79B18	BZX79B18	17.64	18.00	18.36	5	45	225	1.0	0.05	12.6
BZX79B20	BZX79B20	19.60	20.00	20.40	5	55	225	1.0	0.05	14.0
BZX79B22	BZX79B22	21.56	22.00	22.44	5	55	250	1.0	0.05	15.4
BZX79B24	BZX79B24	23.52	24.00	24.48	5	70	250	1.0	0.05	16.8
BZX79B27	BZX79B27	26.46	27.00	27.54	2	80	300	0.5	0.05	18.9
BZX79B30	BZX79B30	29.40	30.00	30.60	2	80	300	0.5	0.05	21.0
BZX79B33	BZX79B33	32.34	33.00	33.66	2	80	325	0.5	0.05	23.1
BZX79B36	BZX79B36	35.28	36.00	36.72	2	90	350	0.5	0.05	25.2
BZX79B39	BZX79B39	38.22	39.00	39.78	2	130	350	0.5	0.05	27.3
BZX79B43	BZX79B43	42.14	43.00	43.86	2	150	375	0.5	0.05	30.1
BZX79B47	BZX79B47	46.06	47.00	47.94	2	170	375	0.5	0.05	32.9
BZX79B51	BZX79B51	49.98	51.00	52.02	2	180	400	0.5	0.05	35.7
BZX79B56	BZX79B56	54.88	56.00	57.12	2	200	425	0.5	0.05	39.2
BZX79B62	BZX79B62	60.76	62.00	63.24	2.5	215	430	0.5	0.05	43.4
BZX79B68	BZX79B68	66.64	68.00	69.36	2.5	240	447	0.5	0.05	47.6
BZX79B75	BZX79B75	73.50	75.00	76.50	2.5	255	470	0.5	0.05	52.5

**Notes:**

- Zener impedance ( $Z_Z$ ) derivation  $Z_{ZT}$  and  $Z_{ZK}$  are measured by dividing the AC voltage drop across the device by the AC current applied. The specified limits are for  $I_{Z(AC)} = 0.1 I_{Z(DC)}$  with the AC frequency = 60Hz.

**ORDERING INFORMATION**

ORDERING CODE <sup>(1)</sup>	PACKAGE	PACKING
BZX79Bx R0G	DO-35	10,000 / 14" Reel
BZX79Bx A0G	DO-35	5,000 / Ammo Box

**Notes:**

- "x" defines voltage from 2.4V (BZX79B2V4) to 75V (BZX79B75)

**PACKAGE OUTLINE DIMENSIONS**

**DO-35**

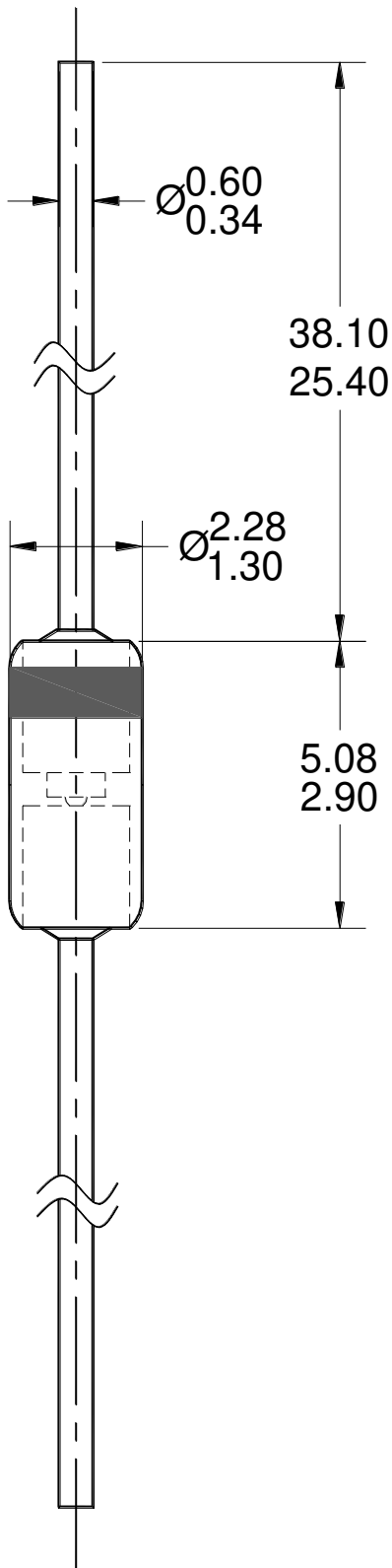

**NOTES: UNLESS OTHERWISE SPECIFIED**

1. ALL DIMENSIONS ARE IN MILLIMETERS.
2. DIMENSIONING AND TOLERANCING PER ASME Y14.5M-1994.
3. DWG NO. REF: HQ2SD07-DO35-058 REV A.



XX = MARKING CODE

**MARKING DIAGRAM**

## **Notice**

Specifications of the products displayed herein are subject to change without notice. TSC or anyone on its behalf assumes no responsibility or liability for any errors or inaccuracies.

Purchasers are solely responsible for the choice, selection, and use of TSC products and TSC assumes no liability for application assistance or the design of Purchasers' products.

Information contained herein is intended to provide a product description only. No license, express or implied, to any intellectual property rights is granted by this document. Except as provided in TSC's terms and conditions of sale for such products, TSC assumes no liability whatsoever, and disclaims any express or implied warranty, relating to sale and/or use of TSC products including liability or warranties relating to fitness for a particular purpose, merchantability, or infringement of any patent, copyright, or other intellectual property right.

The products shown herein are not designed for use in medical, life-saving, or life-sustaining applications. Customers using or selling these products for use in such applications do so at their own risk and agree to fully indemnify TSC for any damages resulting from such improper use or sale.