

COMPONENT TO BE MOLDED IN A CLEAR TRANSMISSIVE POLYCARBONATE.

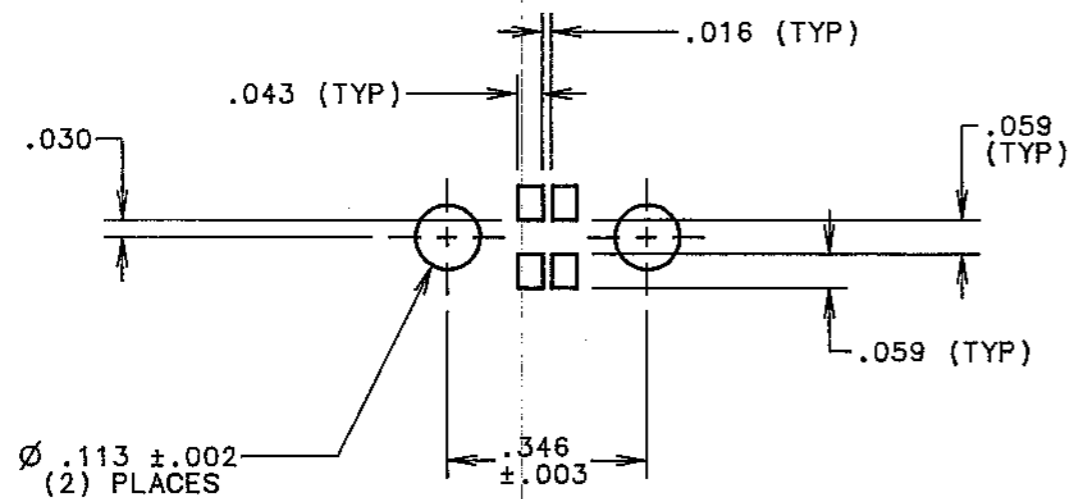

SOLDER PAD AND HOLES LAYOUT

A	NEW RELEASE	M.C. 7, P.	12-15-95
LTR	ECN NO.	REVISIONS	DRN. APP. DATE
THIS DRAWING AND THE CONTENTS HEREIN ARE CONFIDENTIAL AND THE SOLE PROPERTY OF DIALIGHT. REPRODUCTION OF THIS DRAWING OR CONSTRUCTION OF ANY PARTS WITHIN THIS DRAWING ARE FORBIDDEN WITHOUT THE PRIOR WRITTEN CONSENT OF DIALIGHT.			
SCALE: 3:1		CUSTOMER DRAWING NO.	DWG. REV.
TOLERANCES: UNLESS OTHERWISE SPECIFIED ALL DIM'S IN:		C-16048	A
FRACTIONS: $\pm 1/64$		TITLE SINGLE LIGHTPIPE	
DECIMALS(.XX) $\pm .02$		PART NUMBER 515-1038	
DECIMALS(.XXX) $\pm .010$		Dialight	
ANGLES $\pm 3^\circ$		1913 Atlantic Ave.	
FINISH:		Manasquan, NJ 08736	
FSCM	83330		