

THIS DRAWING CONTAINS INFORMATION PROPRIETARY TO RF INDUSTRIES,
 ANY UNAUTHORIZED USE OF THIS DRAWING IS EXPRESSLY PROHIBITED
 WITHOUT WRITTEN PERMISSION FROM RF INDUSTRIES.
 ANY VIOLATION IS PUNISHABLE UNDER U.S. COPYRIGHT LAWS.

ALL DIMENSIONS ARE REFERENCE ONLY

PART NO.		RF123-7002-B		
REV	DESCRIPTION	DWN	DATE	APPROVED
-	ENGINEERING RELEASE	CZS	4/17/00	JMc

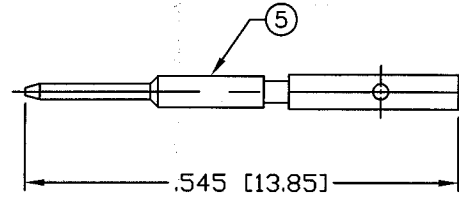
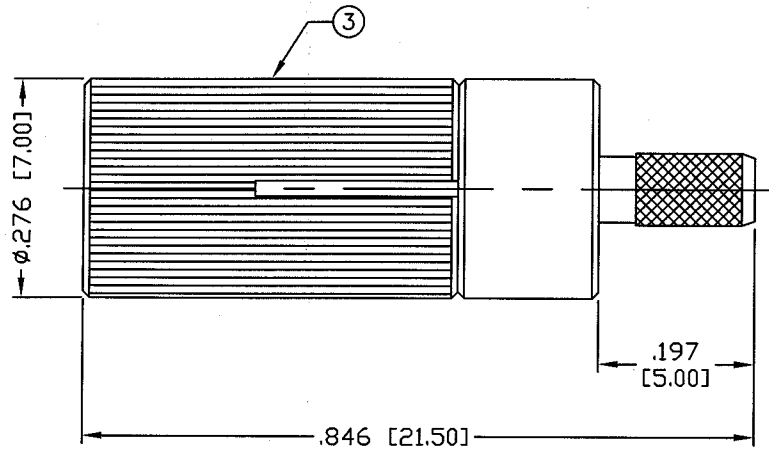

SOLDER OR CRIMP WITH
 RFA-4089 CRIMP TOOL

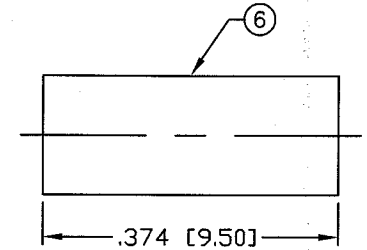

RECOMMENDED CRIMP DIE .128

SPECIFICATIONS:

IMPEDANCE: 50 OHMS
 FREQUENCY RANGE: 0-10 GHz
 WORKING VOLTAGE: 250 V rms @ sea level
 TEMPERATURE RANGE: -65°C TO 155°C
 INSULATION RESISTANCE: 5k M Ohms min.
 FOR RG-174, 188, 188A, 316/U, ALPHA 9174, 9316,
 BELDEN 8216, 83269, 83284, 84316 & TIMES LMR-100A CABLE

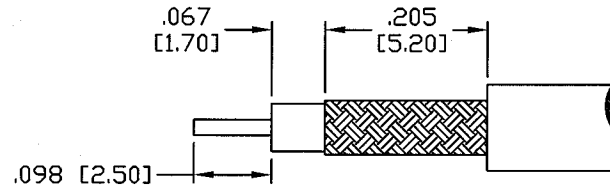

RECOMMENDED STRIPPING DIM'S

1	BODY	1	BRASS	NICKEL, 100 μ "	008974	
2	INSULATOR	1	PTFE	---		
3	COUPLING NUT	1	BRASS	NICKEL, 100 μ "		
4	GROUND RING	1	PHOS. BRONZE	GOLD, 10 μ "		
5	PIN	1	BRASS	GOLD, 30 μ "		
6	FERRULE	1	COPPER	NICKEL, 100 μ "		
7						
8						
9						
10						
11						
12						
13						
14						
#	DESCRIPTION	QTY	MATERIAL	FINISH	APPROVALS	DATE

UNLESS OTHERWISE SPECIFIED:
 1. REMOVE ALL BURRS
 2. BREAK ALL CORNERS & EDGES .005 R. MAX.
 3. CHAMFER 1ST & LAST THREADS 45°
 4. SURFACE ROUGHNESS 63 FINISH MIL-STD-10
 5. DIAMETERS ON COMMON CENTERS TO BE CONCENTRIC WITHIN .002 T.I.R.
 6. ALL DIMENSIONS ARE AFTER PLATING.

DIMENSIONS ARE IN INCHES AND [MILLIMETERS]
 UNLESS OTHERWISE NOTED TOLERANCES ARE:
 DECIMALS DIAMETER
 .XXX±.003 [.08] .XXX±.001 [.03]
 .XX±.005 [.13] .XX±.003 [.08]

DRAWN
 C. ZUNIGA 7/11/01
 CHECKED
 ORJ DRAWN
 C. ZUNIGA 7/11/01

RF connectors
 DIVISION OF RF INDUSTRIES, LTD.
 7610 MIRAMAR RD
 SAN DIEGO, CA 92126
 (858) 549-6340
 (858) 549-6345 FAX

1.0/2.3 PLUG, CRIMP

SIZE	CABLE GROUP	DWG NO.	REV
A	B	RF123-7002-B	-
SCALE: NTS		CAD FILE OUTLINE	SHEET 1 OF 1