



## 2.5V LVDS 1:16 CLOCK BUFFER TERABUFFER™ II

**IDT5T9316**

**PRODUCT DISCONTINUATION NOTICE - LAST TIME BUY EXPIRES ON OCTOBER 28, 2014**

### FEATURES:

- Guaranteed Low Skew < 25ps (max)
- Very low duty cycle distortion < 125ps (max)
- High speed propagation delay < 1.75ns (max)
- Up to 1GHz operation
- Selectable inputs
- Hot insertable and over-voltage tolerant inputs
- 3.3V / 2.5V LVTTTL, HSTL, eHSTL, LVEPECL (2.5V), LVPECL (3.3V), CML, or LVDS input interface
- Selectable differential inputs to sixteen LVDS outputs
- Power-down mode
- 2.5V V<sub>DD</sub>
- Available in VFQFPN package
- use replacement part: 8516FYILF, (8T349316NLGI)

### APPLICATIONS:

- Clock distribution

### DESCRIPTION:

The IDT5T9316 2.5V differential clock buffer is a user-selectable differential input to sixteen LVDS outputs. The fanout from a differential input to sixteen LVDS outputs reduces loading on the preceding driver and provides an efficient clock distribution network. The IDT5T9316 can act as a translator from a differential HSTL, eHSTL, LVEPECL (2.5V), LVPECL (3.3V), CML, or LVDS input to LVDS outputs. A single-ended 3.3V / 2.5V LVTTTL input can also be used to translate to LVDS outputs. The redundant input capability allows for an asynchronous change-over from a primary clock source to a secondary clock source. Selectable reference inputs are controlled by SEL.

The IDT5T9316 outputs can be asynchronously enabled/disabled. When disabled, the outputs will drive to the value selected by the GL pin. Multiple power and grounds reduce noise.

### FUNCTIONAL BLOCK DIAGRAM

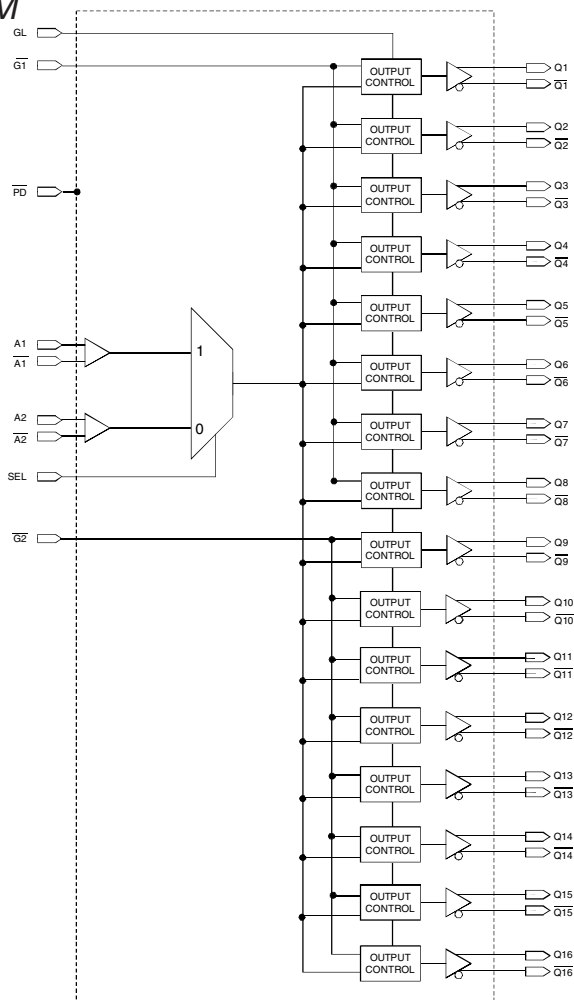

The IDT logo is a registered trademark of Integrated Device Technology, Inc.

**INDUSTRIAL TEMPERATURE RANGE**

**MARCH 20, 2014**

# PIN CONFIGURATION

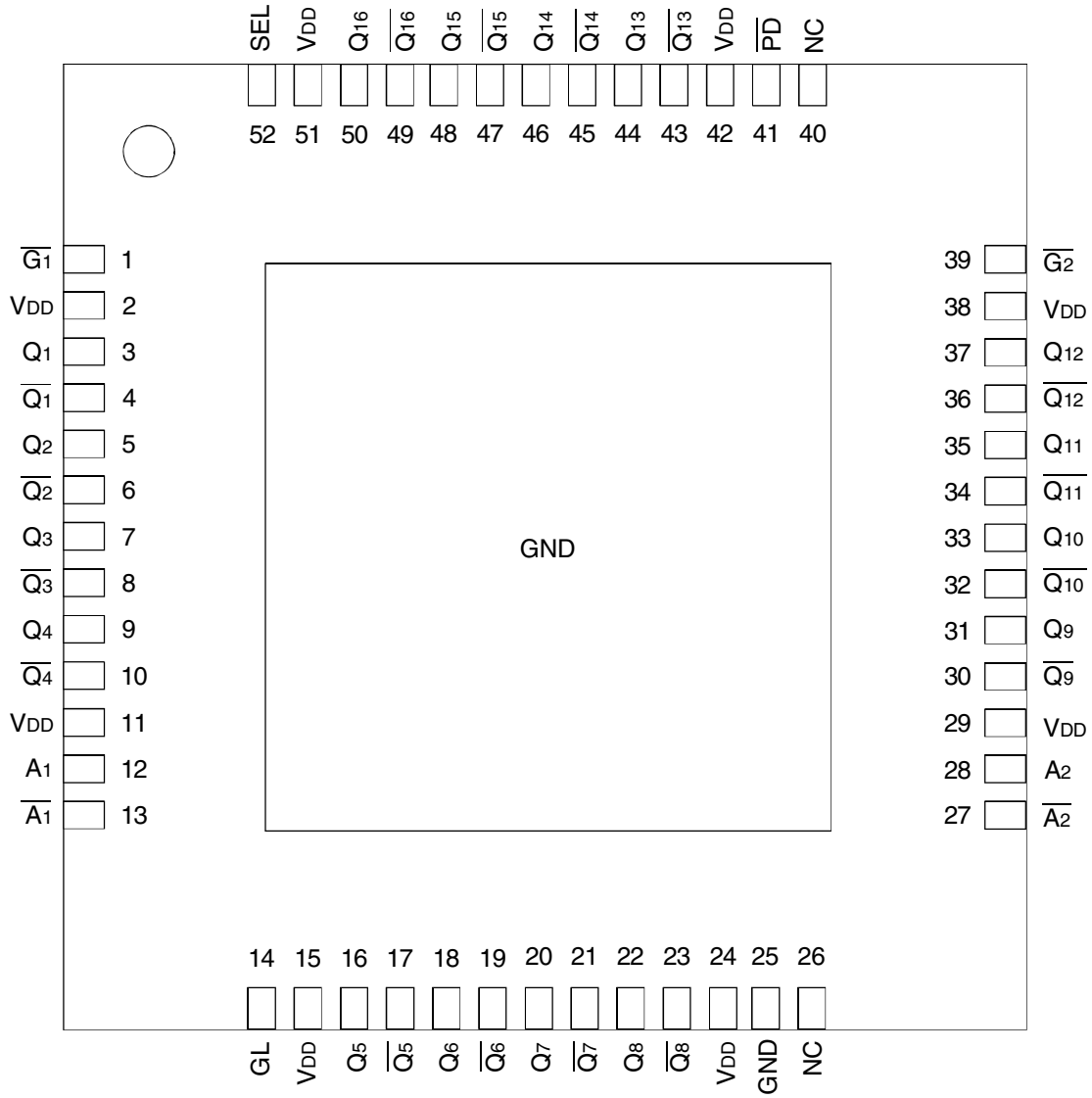

VFQFPN  
TOP VIEW

### ABSOLUTE MAXIMUM RATINGS<sup>(1)</sup>

Symbol	Description	Max	Unit
V <sub>DD</sub>	Power Supply Voltage	-0.5 to +3.6	V
V <sub>I</sub>	Input Voltage	-0.5 to +3.6	V
V <sub>O</sub>	Output Voltage <sup>(2)</sup>	-0.5 to V <sub>DD</sub> +0.5	V
T <sub>STG</sub>	Storage Temperature	-65 to +150	°C
T <sub>J</sub>	Junction Temperature	150	°C

NOTES:

- Stresses greater than those listed under ABSOLUTE MAXIMUM RATINGS may cause permanent damage to the device. This is a stress rating only and functional operation of the device at these or any other conditions above those indicated in the operational sections of this specification is not implied. Exposure to absolute maximum rating conditions for extended periods may affect reliability.
- Not to exceed 3.6V.

### CAPACITANCE<sup>(1)</sup> (T<sub>A</sub> = +25°C, F = 1.0MHz)

Symbol	Parameter	Min	Typ.	Max.	Unit
C <sub>IN</sub>	Input Capacitance	—	—	3	pF

NOTE:

- This parameter is measured at characterization but not tested

### RECOMMENDED OPERATING RANGE

Symbol	Description	Min.	Typ.	Max.	Unit
T <sub>A</sub>	Ambient Operating Temperature	-40	+25	+85	°C
V <sub>DD</sub>	Internal Power Supply Voltage	2.3	2.5	2.7	V

### PIN DESCRIPTION

Symbol	I/O	Type	Description
A <sub>[1:2]</sub>	I	Adjustable <sup>(1,4)</sup>	Clock input. A <sub>[1:2]</sub> is the "true" side of the differential clock input.
$\bar{A}$ <sub>[1:2]</sub>	I	Adjustable <sup>(1,4)</sup>	Complementary clock inputs. $\bar{A}$ <sub>[1:2]</sub> is the complementary side of A <sub>[1:2]</sub> . For LVTTTL single-ended operation, $\bar{A}$ <sub>[1:2]</sub> should be set to the desired toggle voltage for A <sub>[1:2]</sub> : 3.3V LVTTTL V <sub>REF</sub> = 1650mV 2.5V LVTTTL V <sub>REF</sub> = 1250mV
$\bar{G}$ <sub>1</sub>	I	LVTTTL	Gate control for differential outputs Q <sub>1</sub> and $\bar{Q}$ <sub>1</sub> through Q <sub>8</sub> and $\bar{Q}$ <sub>8</sub> . When $\bar{G}$ <sub>1</sub> is LOW, the differential outputs are active. When $\bar{G}$ <sub>1</sub> is HIGH, the differential outputs are asynchronously driven to the level designated by GL <sup>(2)</sup> .
$\bar{G}$ <sub>2</sub>	I	LVTTTL	Gate control for differential outputs Q <sub>9</sub> and $\bar{Q}$ <sub>9</sub> through Q <sub>16</sub> and $\bar{Q}$ <sub>16</sub> . When $\bar{G}$ <sub>2</sub> is LOW, the differential outputs are active. When $\bar{G}$ <sub>2</sub> is HIGH, the differential outputs are asynchronously driven to the level designated by GL <sup>(2)</sup> .
GL	I	LVTTTL	Specifies output disable level. If HIGH, "true" outputs disable HIGH and "complementary" outputs disable LOW. If LOW, "true" outputs disable LOW and "complementary" outputs disable HIGH.
Q <sub>n</sub>	O	LVDS	Clock outputs
$\bar{Q}$ <sub>n</sub>	O	LVDS	Complementary clock outputs
SEL	I	LVTTTL	Reference clock select. When LOW, selects A <sub>2</sub> and $\bar{A}$ <sub>2</sub> . When HIGH, selects A <sub>1</sub> and $\bar{A}$ <sub>1</sub> .
PD	I	LVTTTL	Power-down control. Shuts off entire chip. If LOW, the device goes into low power mode. Inputs and outputs are disabled. Both "true" and "complementary" outputs will pull to V <sub>DD</sub> . Set HIGH for normal operation. <sup>(3)</sup>
V <sub>DD</sub>		PWR	Power supply for the device core and inputs
GND		PWR	Power supply return for all power
NC			No connect; recommended to connect to GND

NOTES:

- Inputs are capable of translating the following interface standards:  
Single-ended 3.3V and 2.5V LVTTTL levels  
Differential HSTL and eHSTL levels  
Differential LVEPECL (2.5V) and LVPECL (3.3V) levels  
Differential LVDS levels  
Differential CML levels
- Because the gate controls are asynchronous, runt pulses are possible. It is the user's responsibility to either time the gate control signals to minimize the possibility of runt pulses or be able to tolerate them in down stream circuitry.
- It is recommended that the outputs be disabled before entering power-down mode. It is also recommended that the outputs remain disabled until the device completes power-up after asserting PD.
- The user must take precautions with any differential input interface standard being used in order to prevent instability when there is no input signal.

DC ELECTRICAL CHARACTERISTICS OVER OPERATING RANGE FOR LVTTTL<sup>(1)</sup>

Symbol	Parameter	Test Conditions	Min.	Typ. <sup>(2)</sup>	Max	Unit
Input Characteristics						
I <sub>IH</sub>	Input HIGH Current	V <sub>DD</sub> = 2.7V	—	—	±5	μA
I <sub>IL</sub>	Input LOW Current	V <sub>DD</sub> = 2.7V	—	—	±5	
V <sub>IK</sub>	Clamp Diode Voltage	V <sub>DD</sub> = 2.3V, I <sub>IN</sub> = -18mA	—	-0.7	-1.2	V
V <sub>IN</sub>	DC Input Voltage		-0.3	—	+3.6	V
V <sub>IH</sub>	DC Input HIGH		1.7	—	—	V
V <sub>IL</sub>	DC Input LOW		—	—	0.7	V
V <sub>THI</sub>	DC Input Threshold Crossing Voltage		—	V <sub>DD</sub> / 2	—	V
V <sub>REF</sub>	Single-Ended Reference Voltage <sup>(3)</sup>	3.3V LVTTTL	—	1.65	—	V
		2.5V LVTTTL	—	1.25	—	

## NOTES:

1. See RECOMMENDED OPERATING RANGE table.
2. Typical values are at V<sub>DD</sub> = 2.5V, +25°C ambient.
3. For A<sub>[1:2]</sub> single-ended operation,  $\bar{A}_{[1:2]}$  is tied to a DC reference voltage.

DC ELECTRICAL CHARACTERISTICS OVER OPERATING RANGE FOR DIFFERENTIAL INPUTS<sup>(1)</sup>

Symbol	Parameter	Test Conditions	Min.	Typ. <sup>(2)</sup>	Max	Unit
Input Characteristics						
I <sub>IH</sub>	Input HIGH Current	V <sub>DD</sub> = 2.7V	—	—	±5	μA
I <sub>IL</sub>	Input LOW Current	V <sub>DD</sub> = 2.7V	—	—	±5	
V <sub>IK</sub>	Clamp Diode Voltage	V <sub>DD</sub> = 2.3V, I <sub>IN</sub> = -18mA	—	-0.7	-1.2	V
V <sub>IN</sub>	DC Input Voltage		-0.3	—	+3.6	V
V <sub>DIF</sub>	DC Differential Voltage <sup>(3)</sup>		0.1	—	—	V
V <sub>CM</sub>	DC Common Mode Input Voltage <sup>(4)</sup>		0.05	—	V <sub>DD</sub>	V

## NOTES:

1. See RECOMMENDED OPERATING RANGE table.
2. Typical values are at V<sub>DD</sub> = 2.5V, +25°C ambient.
3. V<sub>DIF</sub> specifies the minimum input differential voltage (V<sub>TR</sub> - V<sub>CP</sub>) required for switching where V<sub>TR</sub> is the "true" input level and V<sub>CP</sub> is the "complement" input level. The DC differential voltage must be maintained to guarantee retaining the existing HIGH or LOW input. The AC differential voltage must be achieved to guarantee switching to a new state.
4. V<sub>CM</sub> specifies the maximum allowable range of (V<sub>TR</sub> + V<sub>CP</sub>) / 2.

DC ELECTRICAL CHARACTERISTICS OVER RECOMMENDED OPERATING RANGE FOR LVDS<sup>(1)</sup>

Symbol	Parameter	Test Conditions	Min.	Typ. <sup>(2)</sup>	Max	Unit
Output Characteristics						
V <sub>OT(+)</sub>	Differential Output Voltage for the True Binary State		247	—	454	mV
V <sub>OT(-)</sub>	Differential Output Voltage for the False Binary State		247	—	454	mV
ΔV <sub>OT</sub>	Change in V <sub>OT</sub> Between Complementary Output States		—	—	50	mV
V <sub>OS</sub>	Output Common Mode Voltage (Offset Voltage)		1.125	1.2	1.375	V
ΔV <sub>OS</sub>	Change in V <sub>OS</sub> Between Complementary Output States		—	—	50	mV
I <sub>OS</sub>	Outputs Short Circuit Current	V <sub>OUT+</sub> and V <sub>OUT-</sub> = 0V	—	12	24	mA
I <sub>OSD</sub>	Differential Outputs Short Circuit Current	V <sub>OUT+</sub> = V <sub>OUT-</sub>	—	6	12	mA

## NOTES:

1. See RECOMMENDED OPERATING RANGE table.
2. Typical values are at V<sub>DD</sub> = 2.5V, T<sub>A</sub> = +25°C ambient.

### DIFFERENTIAL INPUT AC TEST CONDITIONS FOR HSTL

Symbol	Parameter	Value	Units
V <sub>DIF</sub>	Input Signal Swing <sup>(1)</sup>	1	V
V <sub>X</sub>	Differential Input Signal Crossing Point <sup>(2)</sup>	750	mV
D <sub>H</sub>	Duty Cycle	50	%
V <sub>THI</sub>	Input Timing Measurement Reference Level <sup>(3)</sup>	Crossing Point	V
t <sub>R</sub> , t <sub>F</sub>	Input Signal Edge Rate <sup>(4)</sup>	2	V/ns

NOTES:

1. The 1V peak-to-peak input pulse level is specified to allow consistent, repeatable results in an automatic test equipment (ATE) environment. This device meets the V<sub>DIF</sub> (AC) specification under actual use conditions.
2. A 750mV crossing point level is specified to allow consistent, repeatable results in an automatic test equipment (ATE) environment. This device meets the V<sub>X</sub> specification under actual use conditions.
3. In all cases, input waveform timing is marked at the differential cross-point of the input signals.
4. The input signal edge rate of 2V/ns or greater is to be maintained in the 20% to 80% range of the input waveform.

### DIFFERENTIAL INPUT AC TEST CONDITIONS FOR eHSTL

Symbol	Parameter	Value	Units
V <sub>DIF</sub>	Input Signal Swing <sup>(1)</sup>	1	V
V <sub>X</sub>	Differential Input Signal Crossing Point <sup>(2)</sup>	900	mV
D <sub>H</sub>	Duty Cycle	50	%
V <sub>THI</sub>	Input Timing Measurement Reference Level <sup>(3)</sup>	Crossing Point	V
t <sub>R</sub> , t <sub>F</sub>	Input Signal Edge Rate <sup>(4)</sup>	2	V/ns

NOTES:

1. The 1V peak-to-peak input pulse level is specified to allow consistent, repeatable results in an automatic test equipment (ATE) environment. This device meets the V<sub>DIF</sub> (AC) specification under actual use conditions.
2. A 900mV crossing point level is specified to allow consistent, repeatable results in an automatic test equipment (ATE) environment. This device meets the V<sub>X</sub> specification under actual use conditions.
3. In all cases, input waveform timing is marked at the differential cross-point of the input signals.
4. The input signal edge rate of 2V/ns or greater is to be maintained in the 20% to 80% range of the input waveform.

### DIFFERENTIAL INPUT AC TEST CONDITIONS FOR LVEPECL (2.5V) AND LVPECL (3.3V)

Symbol	Parameter	Value	Units
V <sub>DIF</sub>	Input Signal Swing <sup>(1)</sup>	732	mV
V <sub>X</sub>	Differential Input Signal Crossing Point <sup>(2)</sup>	LVEPECL	1082
		LVPECL	1880
D <sub>H</sub>	Duty Cycle	50	%
V <sub>THI</sub>	Input Timing Measurement Reference Level <sup>(3)</sup>	Crossing Point	V
t <sub>R</sub> , t <sub>F</sub>	Input Signal Edge Rate <sup>(4)</sup>	2	V/ns

NOTES:

1. The 732mV peak-to-peak input pulse level is specified to allow consistent, repeatable results in an automatic test equipment (ATE) environment. This device meets the V<sub>DIF</sub> (AC) specification under actual use conditions.
2. 1082mV LVEPECL (2.5V) and 1880mV LVPECL (3.3V) crossing point levels are specified to allow consistent, repeatable results in an automatic test equipment (ATE) environment. This device meets the V<sub>X</sub> specification under actual use conditions.
3. In all cases, input waveform timing is marked at the differential cross-point of the input signals.
4. The input signal edge rate of 2V/ns or greater is to be maintained in the 20% to 80% range of the input waveform.

## DIFFERENTIAL INPUT AC TEST CONDITIONS FOR LVDS

Symbol	Parameter	Value	Units
V <sub>DIF</sub>	Input Signal Swing <sup>(1)</sup>	400	mV
V <sub>X</sub>	Differential Input Signal Crossing Point <sup>(2)</sup>	1.2	V
D <sub>H</sub>	Duty Cycle	50	%
V <sub>THI</sub>	Input Timing Measurement Reference Level <sup>(3)</sup>	Crossing Point	V
t <sub>R</sub> , t <sub>F</sub>	Input Signal Edge Rate <sup>(4)</sup>	2	V/ns

### NOTES:

1. The 400mV peak-to-peak input pulse level is specified to allow consistent, repeatable results in an automatic test equipment (ATE) environment. This device meets the V<sub>DIF</sub> (AC) specification under actual use conditions.
2. A 1.2V crossing point level is specified to allow consistent, repeatable results in an automatic test equipment (ATE) environment. This device meets the V<sub>X</sub> specification under actual use conditions.
3. In all cases, input waveform timing is marked at the differential cross-point of the input signals.
4. The input signal edge rate of 2V/ns or greater is to be maintained in the 20% to 80% range of the input waveform.

## AC DIFFERENTIAL INPUT SPECIFICATIONS<sup>(1)</sup>

Symbol	Parameter	Min.	Typ.	Max	Unit
V <sub>DIF</sub>	AC Differential Voltage <sup>(2)</sup>	0.1	—	3.6	V
V <sub>IX</sub>	Differential Input Crosspoint Voltage	0.05	—	V <sub>DD</sub>	V
V <sub>CM</sub>	Common Mode Input Voltage Range <sup>(3)</sup>	0.05	—	V <sub>DD</sub>	V
V <sub>IN</sub>	Input Voltage	-0.3		+3.6	V

### NOTES:

1. The output will not change state until the inputs have crossed and the minimum differential voltage range defined by V<sub>DIF</sub> has been met or exceeded.
2. V<sub>DIF</sub> specifies the minimum input voltage (V<sub>TR</sub> - V<sub>CP</sub>) required for switching where V<sub>TR</sub> is the "true" input level and V<sub>CP</sub> is the "complement" input level. The AC differential voltage must be achieved to guarantee switching to a new state.
3. V<sub>CM</sub> specifies the maximum allowable range of (V<sub>TR</sub> + V<sub>CP</sub>) /2.

## POWER SUPPLY CHARACTERISTICS FOR LVDS OUTPUTS<sup>(1)</sup>

Symbol	Parameter	Test Conditions	Typ.	Max	Unit
I <sub>DDQ</sub>	Quiescent V <sub>DD</sub> Power Supply Current	V <sub>DD</sub> = Max., All Input Clocks = LOW <sup>(2)</sup> Outputs enabled	—	350	mA
I <sub>TOT</sub>	Total Power V <sub>DD</sub> Supply Current	V <sub>DD</sub> = 2.7V., F <sub>REFERENCE CLOCK</sub> = 1GHz	—	360	mA
I <sub>PD</sub>	Total Power Down Supply Current	$\overline{PD}$ = LOW	—	5	mA

### NOTES:

1. These power consumption characteristics are for all the valid input interfaces and cover the worst case conditions.
2. The true input is held LOW and the complementary input is held HIGH.

AC ELECTRICAL CHARACTERISTICS OVER OPERATING RANGE<sup>(1,5)</sup>

Symbol	Parameter	Min.	Typ.	Max	Unit
--------	-----------	------	------	-----	------

## Skew Parameters

$t_{SK(O)}$	Same Device Output Pin-to-Pin Skew <sup>(2)</sup>	—	—	25	ps
$t_{SK(P)}$	Pulse Skew <sup>(3)</sup>	—	—	125	ps
$t_{SK(PP)}$	Part-to-Part Skew <sup>(4)</sup>	—	—	300	ps

## Propagation Delay

$t_{PLH}$	Propagation Delay A, $\overline{A}$ Crosspoint to $Q_n, \overline{Q_n}$ Crosspoint	—	1.25	1.75	ns
$t_{PHL}$					
$f_o$	Frequency Range <sup>(6)</sup>	—	—	1	GHz

## Output Gate Enable/Disable Delay

$t_{PGE}$	Output Gate Enable Crossing $V_{THI}$ to $Q_n/\overline{Q_n}$ Crosspoint	—	—	3.5	ns
$t_{PGD}$	Output Gate Disable Crossing $V_{THI}$ to $Q_n/\overline{Q_n}$ Crosspoint Driven to GL Designated Level	—	—	3.5	ns

## Power Down Timing

$t_{PWRDN}$	$\overline{PD}$ Crossing $V_{THI}$ to $Q_n = V_{DD}, \overline{Q_n} = V_{DD}$	—	—	100	$\mu$ S
$t_{PWRUP}$	Output Gate Disable Crossing $V_{THI}$ to $Q_n/\overline{Q_n}$ Driven to GL Designated Level	—	—	100	$\mu$ S

## NOTES:

- AC propagation measurements should not be taken within the first 100 cycles of startup.
- Skew measured between crosspoints of all differential output pairs under identical input and output interfaces, transitions and load conditions on any one device.
- Skew measured is the difference between propagation delay times  $t_{PHL}$  and  $t_{PLH}$  of any differential output pair under identical input and output interfaces, transitions and load conditions on any one device.
- Skew measured is the magnitude of the difference in propagation times between any single differential output pair of two devices, given identical transitions and load conditions at identical  $V_{DD}$  levels and temperature.
- All parameters are tested with a 50% input duty cycle.
- Guaranteed by design but not production tested.

## DIFFERENTIAL AC TIMING WAVEFORMS

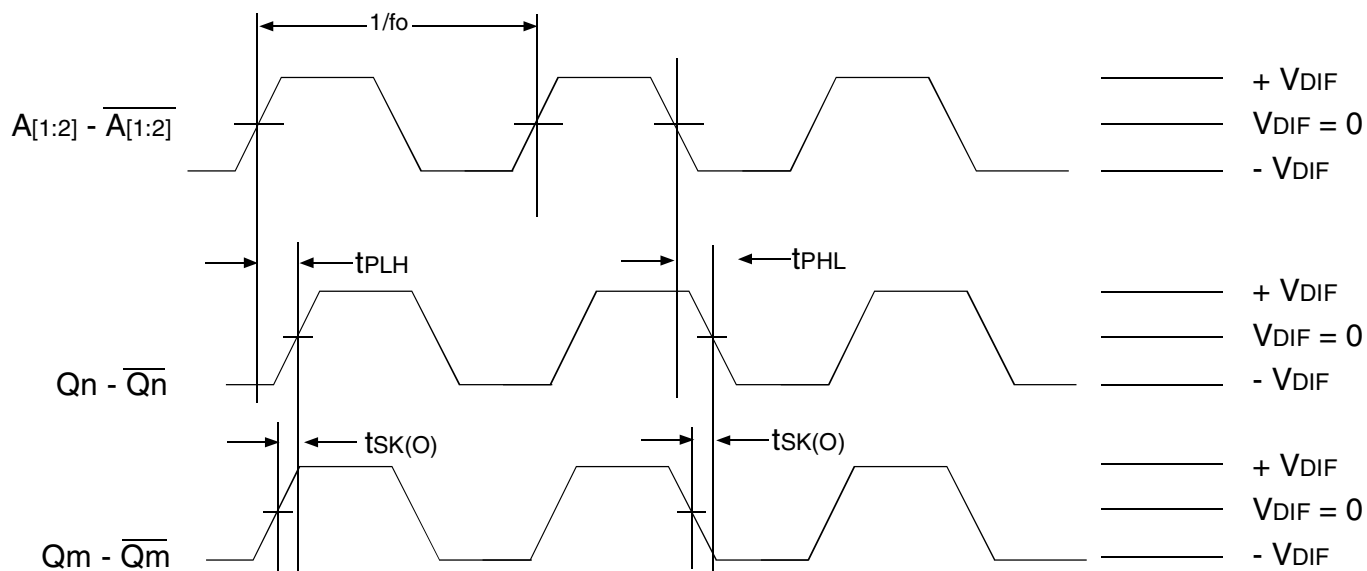

*Output Propagation and Skew Waveforms*

**NOTES:**

1. Pulse skew is calculated using the following expression:

$$t_{SK(P)} = |t_{PHL} - t_{PLH}|$$

Note that the  $t_{PHL}$  and  $t_{PLH}$  shown above are not valid measurements for this calculation because they are not taken from the same pulse.

2. AC propagation measurements should not be taken within the first 100 cycles of startup.



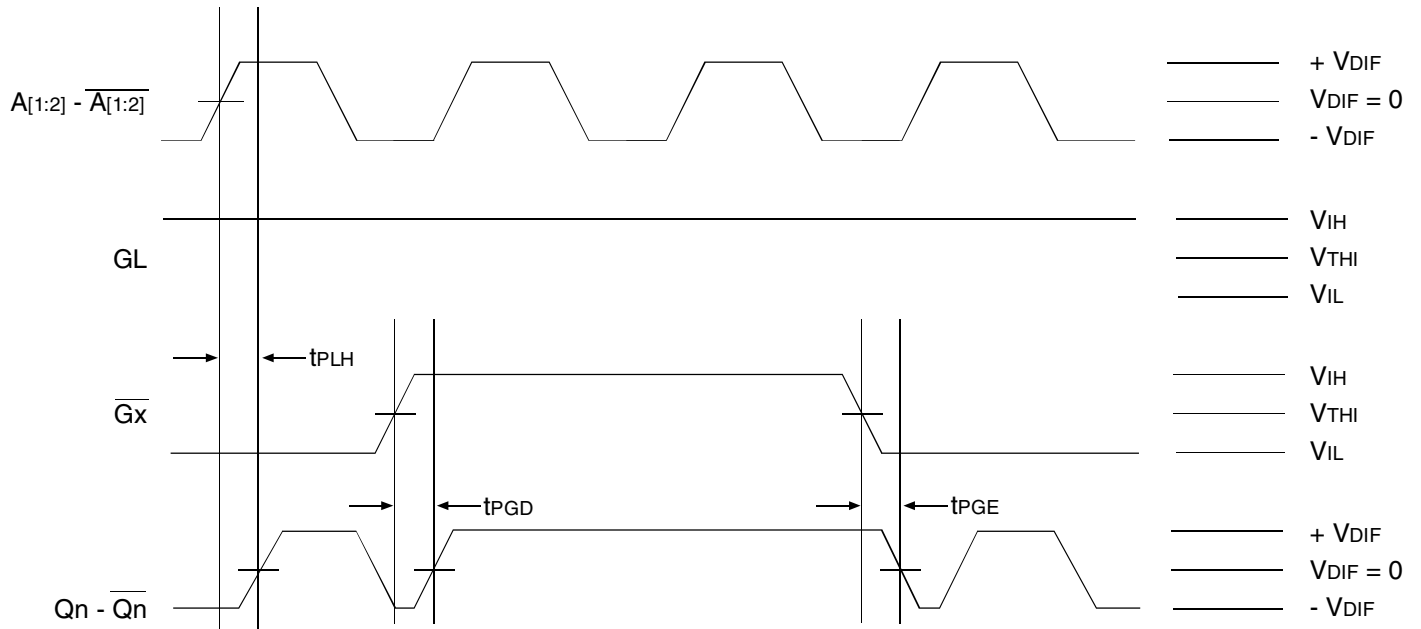

Differential Gate Disable/Enable Showing Runt Pulse Generation

NOTE:  
1. As shown, it is possible to generate runt pulses on gate disable and enable of the outputs. It is the user's responsibility to time their  $\overline{Gx}$  signals to avoid this problem.

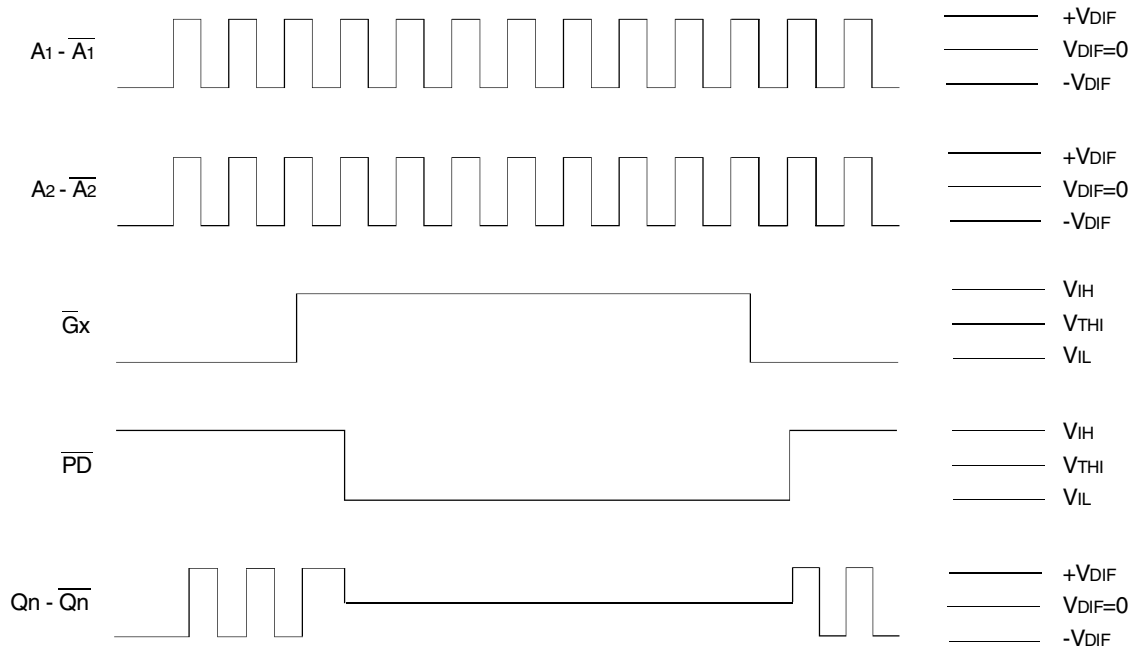

Power Down Timing

NOTES:  
1. It is recommended that outputs be disabled before entering power-down mode. It is also recommended that the outputs remain disabled until the device completes power-up after asserting  $\overline{PD}$ .  
2. The POWER DOWN TIMING diagram assumes that  $GL$  is HIGH.  
3. It should be noted that during power-down mode, the outputs are both pulled to  $V_{DD}$ . In the POWER DOWN TIMING diagram this is shown when  $Qn - \overline{Qn}$  goes to  $V_{DIF} = 0$ .

### TEST CIRCUITS AND CONDITIONS

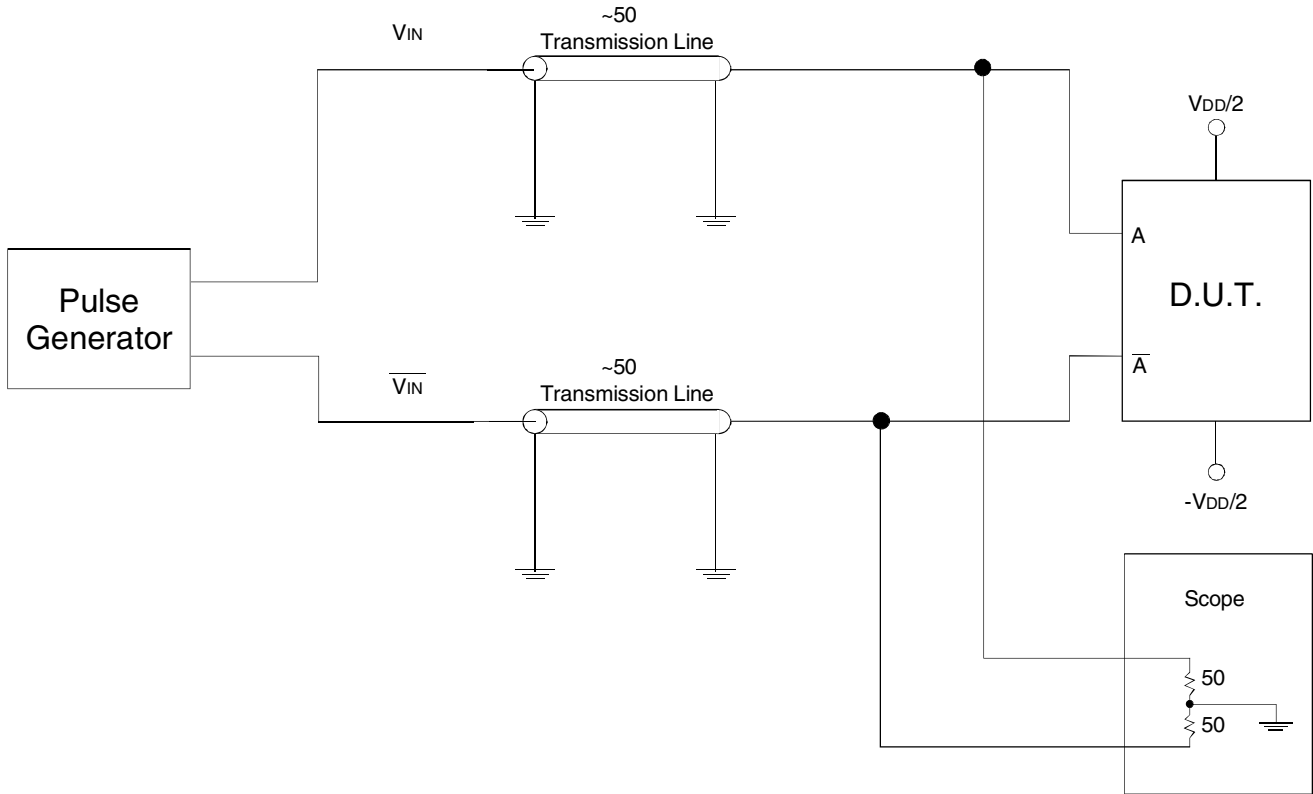

Test Circuit for Differential Input

### DIFFERENTIAL INPUT TEST CONDITIONS

Symbol	$V_{DD} = 2.5V \pm 0.2V$	Unit
$V_{THI}$	Crossing of A and $\overline{A}$	V

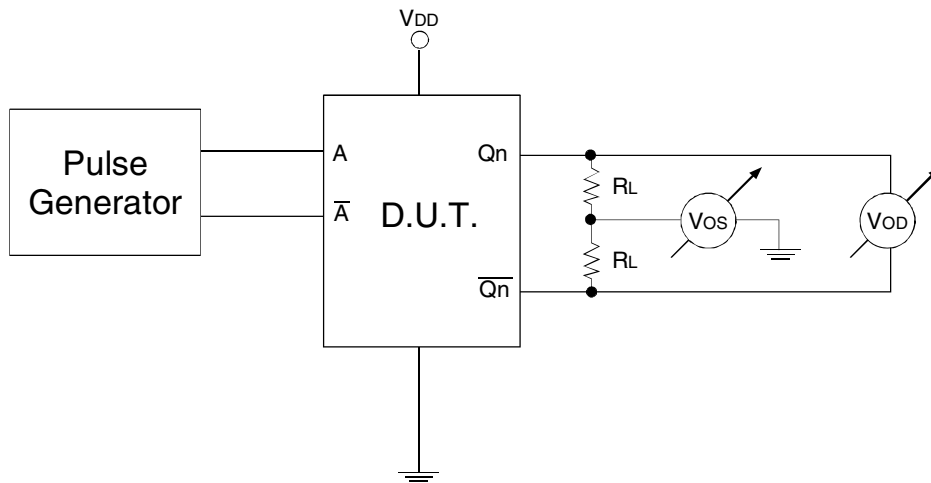

Test Circuit for DC Outputs and Power Down Tests

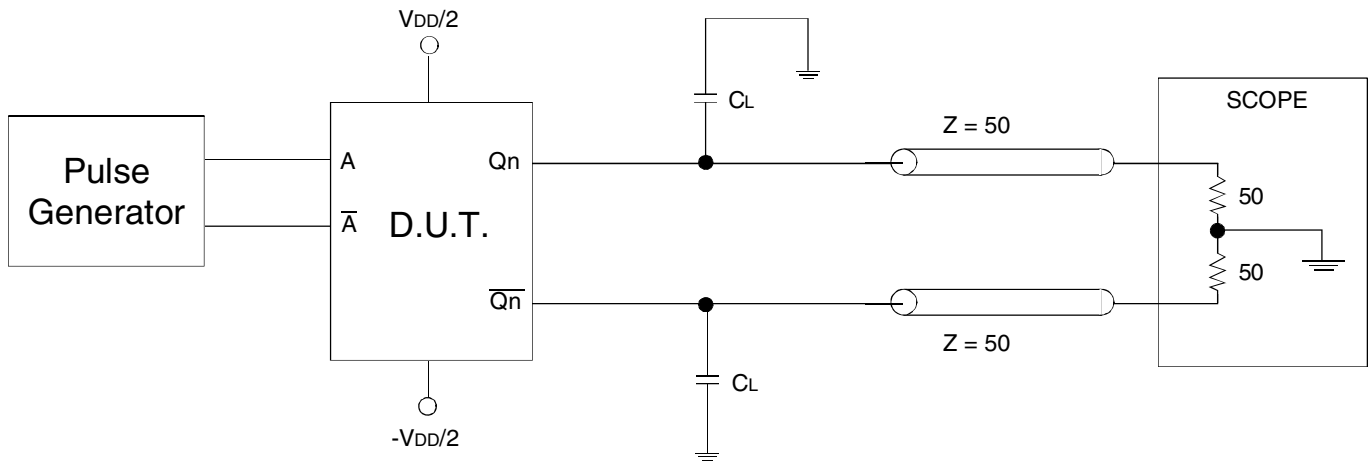

Test Circuit for Propagation, Skew, and Gate Enable/Disable Timing

### LVDS OUTPUT TEST CONDITION

Symbol	$V_{DD} = 2.5V \pm 0.2V$	Unit
$C_L$	$0^{(1)}$	pF
	$8^{(1,2)}$	
$R_L$	50	$\Omega$

NOTES:

- Specifications only apply to "Normal Operations" test condition. The T1A/E1A specification load is for reference only.
- The scope inputs are assumed to have a 2pF load to ground. T1A/E1A - 644 specifies 5pF between the output pair. With  $C_L = 8pF$ , this gives the test circuit appropriate 5pF equivalent load.

### RECOMMENDED LANDING PATTERN

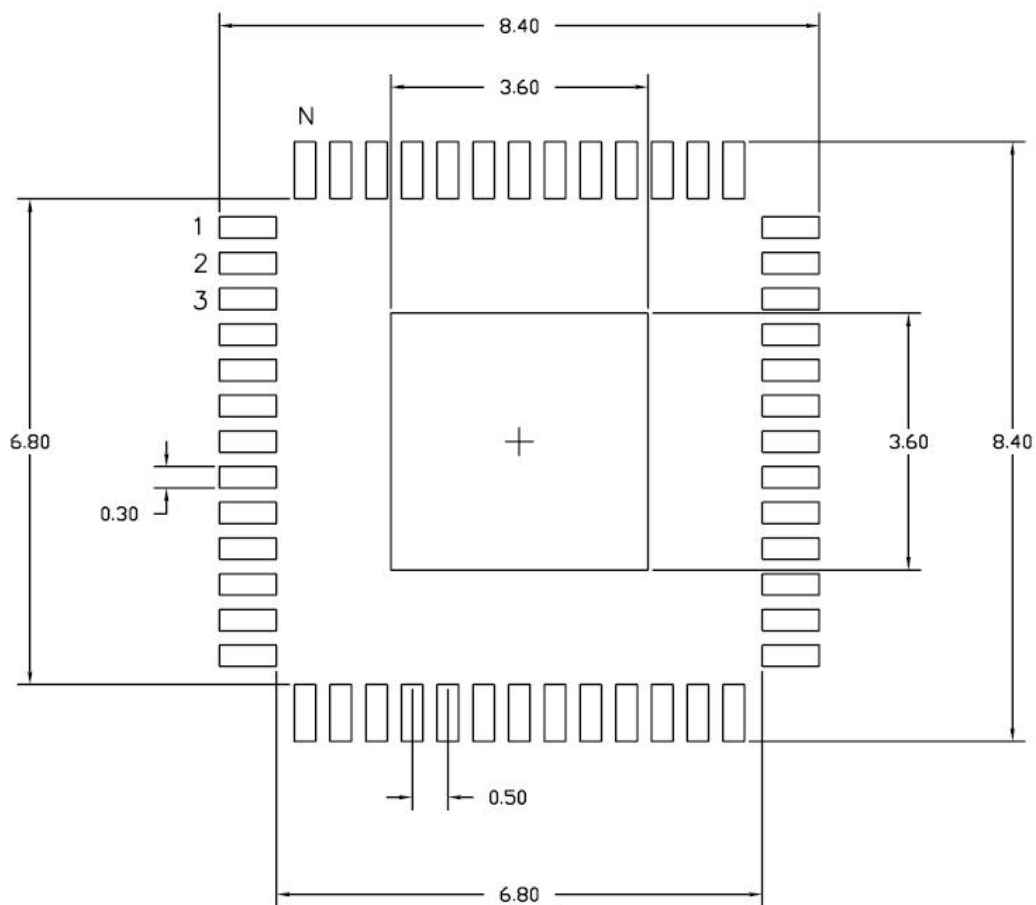

NL 52 pin

NOTE: All dimensions are in millimeters.

### ORDERING INFORMATION

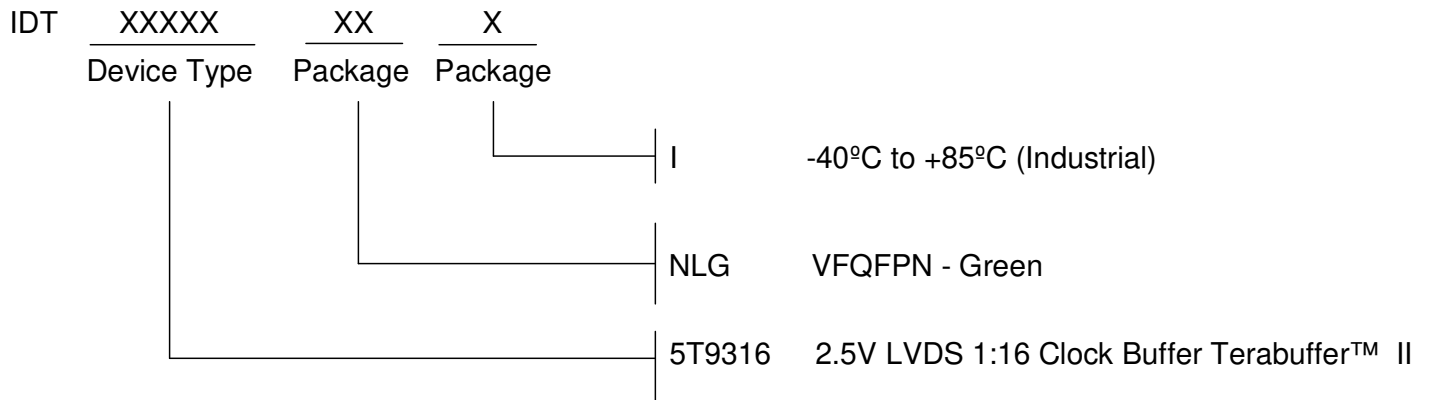

## REVISION HISTORY

Rev	Table	Page	Description of Change	Date
A		1	NRND - Not Recommended for New Designs	5/16/13
A		1	Product Discontinuation Notice - Last Time Buy Expires on October 28, 2014, PDN# CQ-13-02	11/27/13
A		1	Added new additional replacement part number	3/21/14

## We've Got Your Timing Solution.



6024 Silver Creek Valley Road  
San Jose, CA 95138

### Sales

800-345-7015 (inside USA)  
+408-284-8200 (outside USA)  
Fax: 408-284-2775  
[www.IDT.com/go/contactIDT](http://www.IDT.com/go/contactIDT)

### Tech Support

[netcom@idt.com](mailto:netcom@idt.com)  
+480-763-2056

DISCLAIMER Integrated Device Technology, Inc. (IDT) and its subsidiaries reserve the right to modify the products and/or specifications described herein at any time and at IDT's sole discretion. All information in this document, including descriptions of product features and performance, is subject to change without notice. Performance specifications and the operating parameters of the described products are determined in the independent state and are not guaranteed to perform the same way when installed in customer products. The information contained herein is provided without representation or warranty of any kind, whether express or implied, including, but not limited to, the suitability of IDT's products for any particular purpose, an implied warranty of merchantability, or non-infringement of the intellectual property rights of others. This document is presented only as a guide and does not convey any license under intellectual property rights of IDT or any third parties.

IDT's products are not intended for use in applications involving extreme environmental conditions or in life support systems or similar devices where the failure or malfunction of an IDT product can be reasonably expected to significantly affect the health or safety of users. Anyone using an IDT product in such a manner does so at their own risk, absent an express, written agreement by IDT.

Integrated Device Technology, IDT and the IDT logo are registered trademarks of IDT. Other trademarks and service marks used herein, including protected names, logos and designs, are the property of IDT or their respective third party owners.

Copyright 2014 All rights reserved.