

THIS DRAWING IS UNPUBLISHED. RELEASED FOR PUBLICATION 20  
 © COPYRIGHT 20 BY - ALL RIGHTS RESERVED.

| REVISIONS |     |                                |           |       |
|-----------|-----|--------------------------------|-----------|-------|
| P         | LTR | DESCRIPTION                    | DATE      | APVD  |
| 1         |     | INITIAL RELEASE                | 23AUG2018 | SH SH |
| 2         |     | ADDED DIMENSION FOR PLUGGED IN | 09NOV2018 | SH SH |
| A         |     | INITIAL RELEASE                | 12JUN2019 | SH SH |

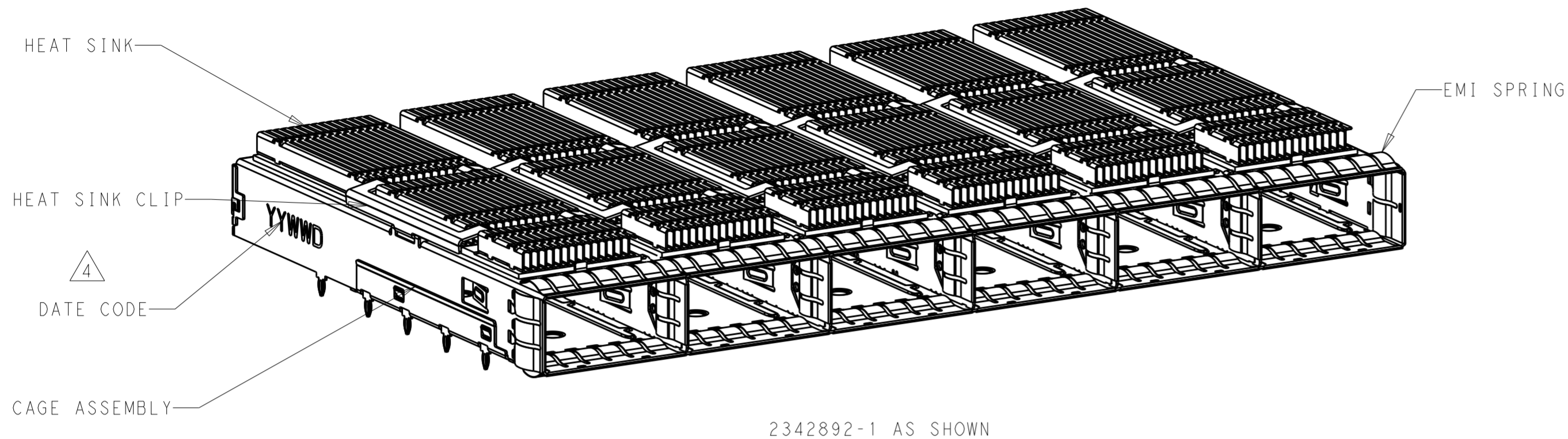

- 1 CAGE ASSEMBLY: STAINLESS STEEL  
HEAT SINK: ALUMINUM/NICKEL PLATED  
HEAT SINK CLIP: STAINLESS STEEL  
EMI SPRING: COPPER ALLOY/ NICKEL PLATED
- 2 REFERENCE APPLICATION SPECIFICATION 114-60025 FOR RECOMMENDED DRILL HOLE DIAMETER AND PLATING THICKNESS. BOARD LAYOUT PER THIS PRINT.
- 3 DATUM AND BASIC DIMENSION ESTABLISHED BY CUSTOMER
- 4 DATE CODE(YYWWD) MARKED APPROXIMATELY AS SHOWN.
- 5. MATES WIHT QSFP-DD MSA COMPATIBLE TRANSCEIVER.
- 6. MINIMUM PC BOARD THICKNESS:  
SINGLE SIDED: 1.57 MIN  
DOUBLE SIDED: 3.00 MIN

2342892-1 AS SHOWN

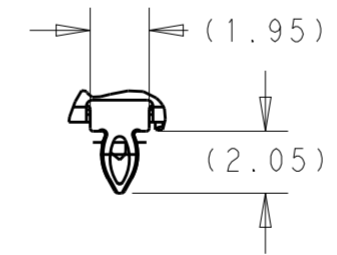
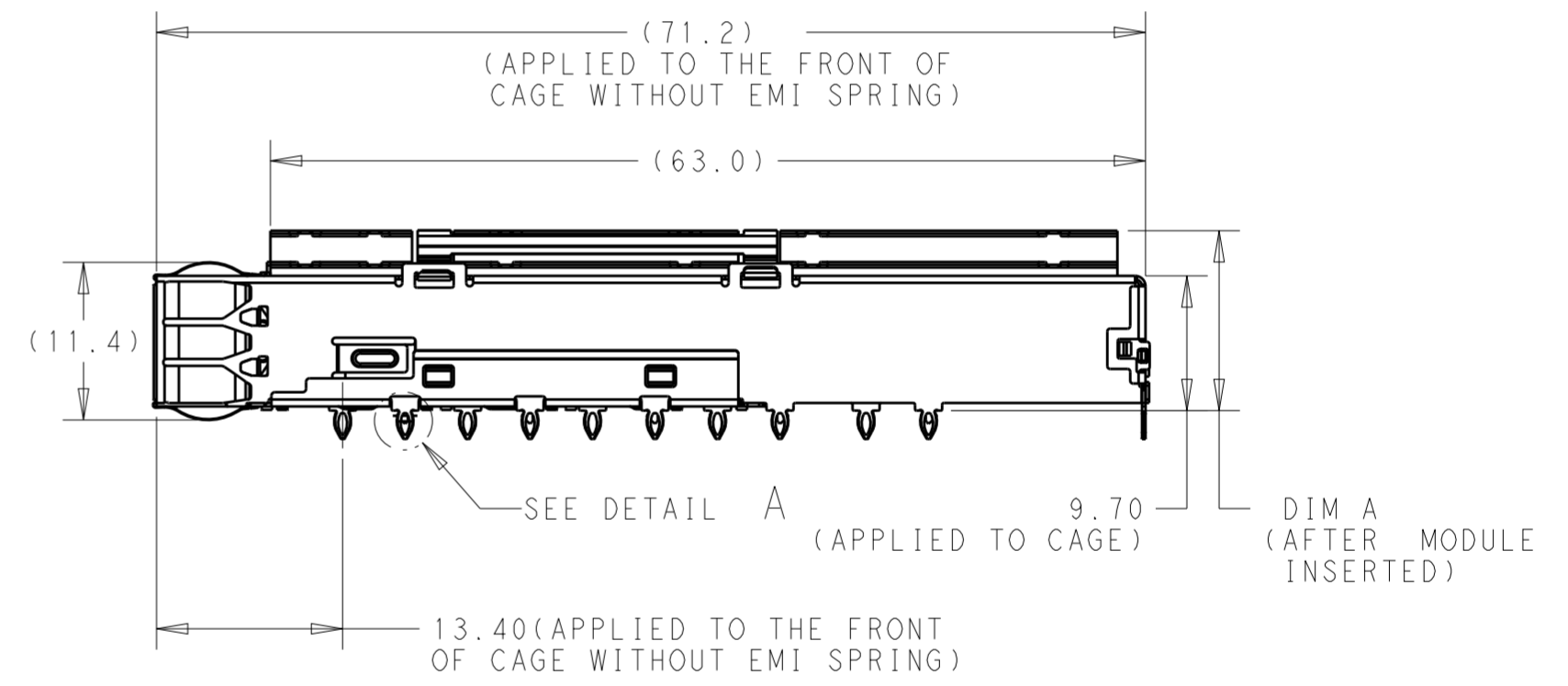
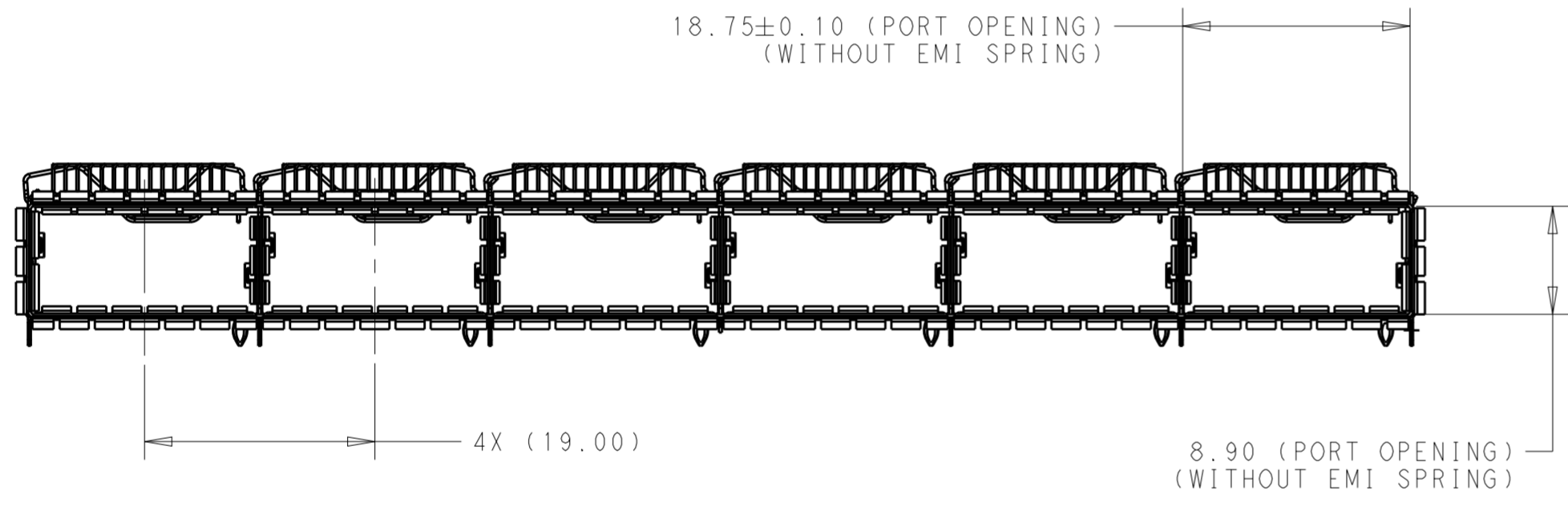

2342892-1 AS SHOWN

DETAIL A  
SCALE 4:1

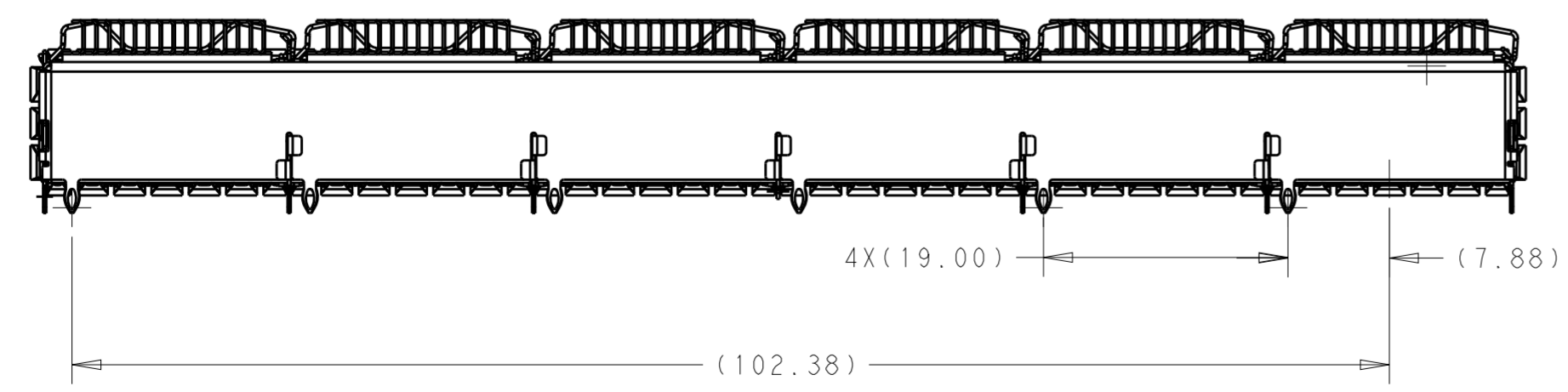

SCALE 2:1

| HS SPECIFICATION | DIM A | PART NUMBER | DESCRIPTION           | ITEM |
|------------------|-------|-------------|-----------------------|------|
| NET              | 23.00 | 2342892-3   | CAGE ASSY WITH NET HS | 3    |
| SAN              | 16.00 | 2342892-2   | CAGE ASSY WITH SAN HS | 2    |
| PCI              | 13.70 | 2342892-1   | CAGE ASSY WITH PCI HS | 1    |

|  |   |                             |                 |                                     |              |               |
|--|---|-----------------------------|-----------------|-------------------------------------|--------------|---------------|
| THIS DRAWING IS A CONTROLLED DOCUMENT. |   | DWN 23AUG2018<br>STEPHEN HE | TE Connectivity | NAME                                |              |               |
| DIMENSIONS:                            |   | CHK 23AUG2018<br>SEAN HAN   |                 | CAGE ASSEMBLY WIHT HEAT SINK FOR GM |              |               |
| TOLERANCES UNLESS OTHERWISE SPECIFIED: |   | APVD 23AUG2018<br>SEAN HAN  |                 | QSFP-DD 1X6 ZIPPER                  |              |               |
| mm                                     | 0 PLC ±0.25<br>1 PLC ±0.25<br>2 PLC ±0.25<br>3 PLC ±<br>4 PLC ± | PRODUCT SPEC                | SIZE            | CAGE CODE                           | DRAWING NO   | RESTRICTED TO |
| MATERIAL                               | ANGLES ±1<br>FINISH   | APPLICATION SPEC            | A2              | -                                   | ©-2342892    | -             |
|  |   | WEIGHT                      | SCALE 1:1       |                                     | SHEET 1 OF 5 | REV A         |
|  |   | CUSTOMER DRAWING            |                 |                                     |              |               |

THIS DRAWING IS UNPUBLISHED. RELEASED FOR PUBLICATION 20  
 © COPYRIGHT 20 BY - ALL RIGHTS RESERVED.

| REVISIONS |     |             |      |      |
|-----------|-----|-------------|------|------|
| P         | LTR | DESCRIPTION | DATE | APVD |
| -         | -   | SEE SHEET 1 | -    | -    |
|           |     |             |      |      |
|           |     |             |      |      |

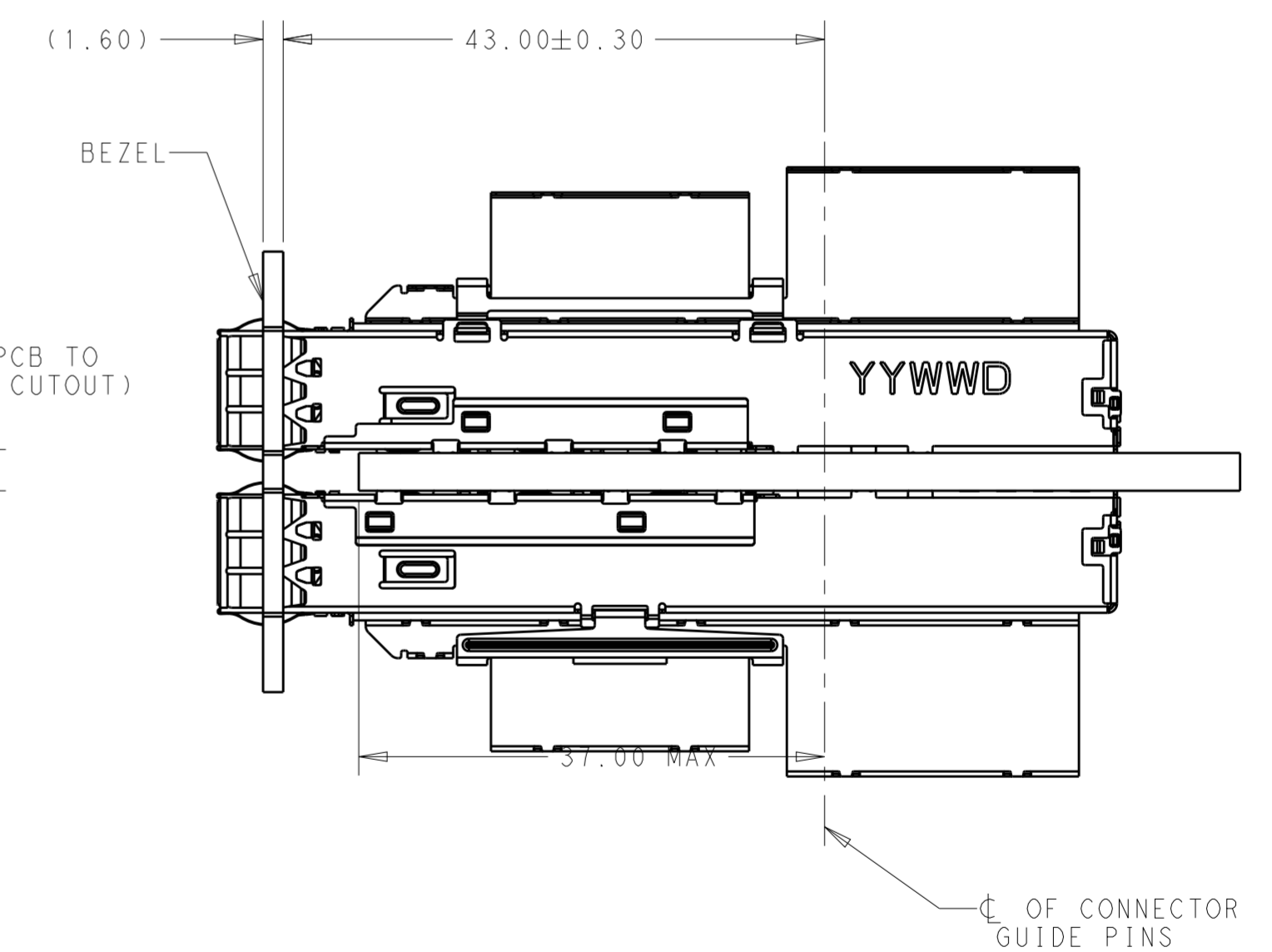
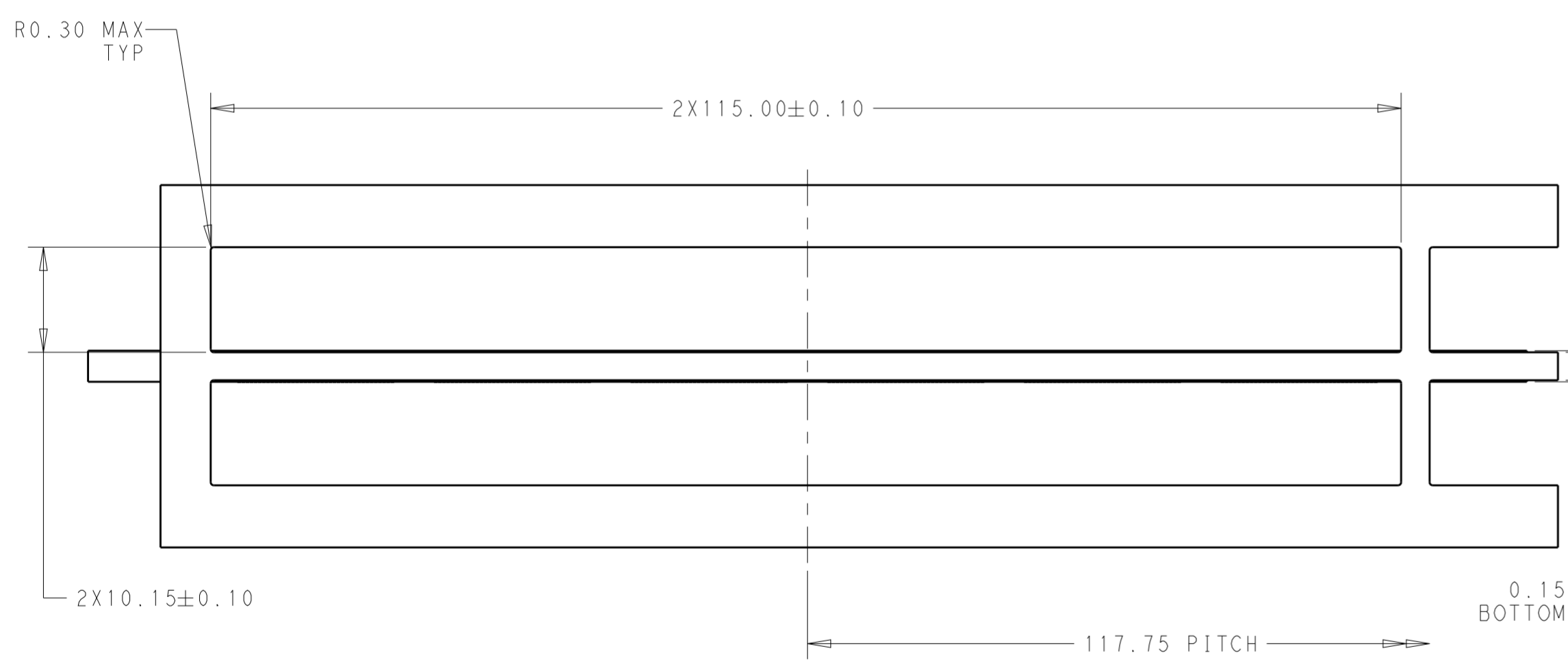
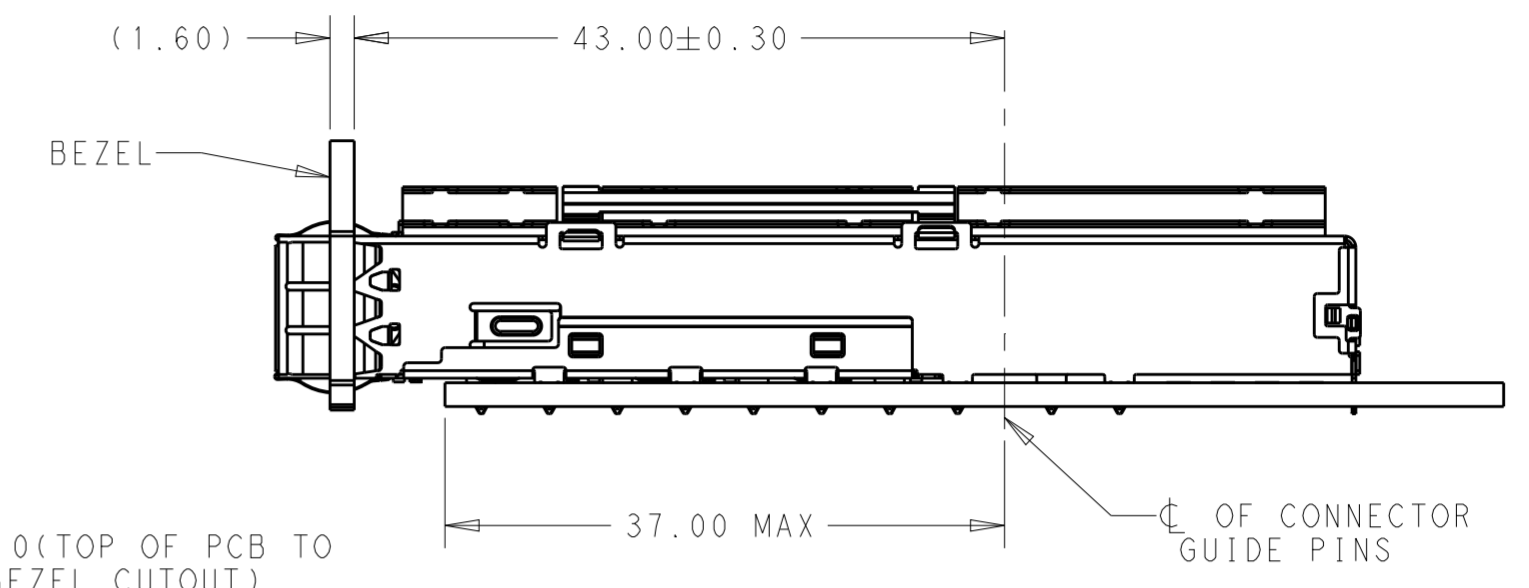
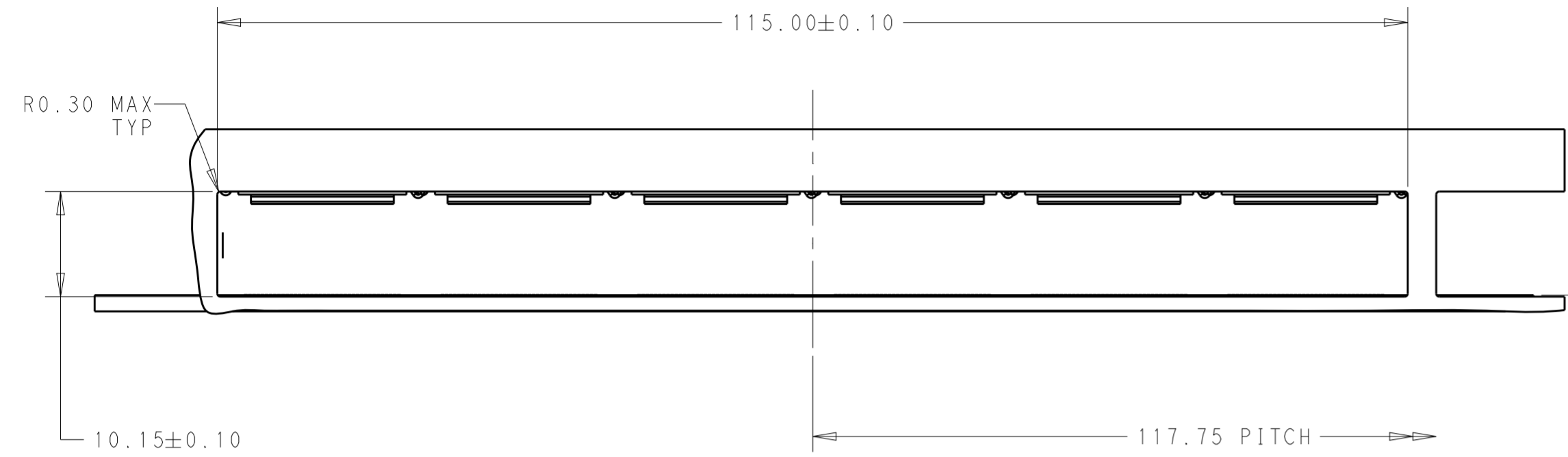

|  |  |                                |   |       |       |       |       |   |       |   |        |    |        |   |  |          |   |        |   |                  |   |   |              |   |                  |   |        |   |                  |   |  |      |    |           |   |            |           |               |   |
|--|--|--------------------------------|---|-------|-------|-------|-------|---|-------|---|--------|----|--------|---|--|----------|---|--------|---|------------------|---|---|--------------|---|------------------|---|--------|---|------------------|---|--|------|----|-----------|---|------------|-----------|---------------|---|
| THIS DRAWING IS A CONTROLLED DOCUMENT.   |  | DWN<br>STEPHEN HE<br>23AUG2018 | TE Connectivity   |       |       |       |       |   |       |   |        |    |        |   |  |          |   |        |   |                  |   |   |              |   |                  |   |        |   |                  |   |  |      |    |           |   |            |           |               |   |
| DIMENSIONS:  |  | CHK<br>SEAN HAN<br>23AUG2018   |   |       |       |       |       |   |       |   |        |    |        |   |  |          |   |        |   |                  |   |   |              |   |                  |   |        |   |                  |   |  |      |    |           |   |            |           |               |   |
| mm   | TOLERANCES UNLESS OTHERWISE SPECIFIED: | APVD<br>SEAN HAN<br>23AUG2018  | NAME<br>CAGE ASSEMBLY WIHT HEAT SINK FOR GM<br>QSFP-DD 1X6 ZIPPER |       |       |       |       |   |       |   |        |    |        |   |  |          |   |        |   |                  |   |   |              |   |                  |   |        |   |                  |   |  |      |    |           |   |            |           |               |   |
| <table border="1"> <tr><td>0 PLC</td><td>±0.25</td></tr> <tr><td>1 PLC</td><td>±0.25</td></tr> <tr><td>2 PLC</td><td>±0.25</td></tr> <tr><td>3 PLC</td><td>±</td></tr> <tr><td>4 PLC</td><td>±</td></tr> <tr><td>ANGLES</td><td>±1</td></tr> <tr><td>FINISH</td><td>-</td></tr> </table> | 0 PLC                                  | ±0.25                          | 1 PLC   | ±0.25 | 2 PLC | ±0.25 | 3 PLC | ± | 4 PLC | ± | ANGLES | ±1 | FINISH | - | <table border="1"> <tr><td>MATERIAL</td><td>-</td></tr> <tr><td>WEIGHT</td><td>-</td></tr> <tr><td>CUSTOMER DRAWING</td><td>-</td></tr> </table> | MATERIAL | - | WEIGHT | - | CUSTOMER DRAWING | - | <table border="1"> <tr><td>PRODUCT SPEC</td><td>-</td></tr> <tr><td>APPLICATION SPEC</td><td>-</td></tr> <tr><td>WEIGHT</td><td>-</td></tr> <tr><td>CUSTOMER DRAWING</td><td>-</td></tr> </table> | PRODUCT SPEC | - | APPLICATION SPEC | - | WEIGHT | - | CUSTOMER DRAWING | - | <table border="1"> <tr><td>SIZE</td><td>A2</td></tr> <tr><td>CAGE CODE</td><td>-</td></tr> <tr><td>DRAWING NO</td><td>C-2342891</td></tr> <tr><td>RESTRICTED TO</td><td>-</td></tr> </table> | SIZE | A2 | CAGE CODE | - | DRAWING NO | C-2342891 | RESTRICTED TO | - |
| 0 PLC  | ±0.25                                  |                                |   |       |       |       |       |   |       |   |        |    |        |   |  |          |   |        |   |                  |   |   |              |   |                  |   |        |   |                  |   |  |      |    |           |   |            |           |               |   |
| 1 PLC  | ±0.25                                  |                                |   |       |       |       |       |   |       |   |        |    |        |   |  |          |   |        |   |                  |   |   |              |   |                  |   |        |   |                  |   |  |      |    |           |   |            |           |               |   |
| 2 PLC  | ±0.25                                  |                                |   |       |       |       |       |   |       |   |        |    |        |   |  |          |   |        |   |                  |   |   |              |   |                  |   |        |   |                  |   |  |      |    |           |   |            |           |               |   |
| 3 PLC  | ±                                      |                                |   |       |       |       |       |   |       |   |        |    |        |   |  |          |   |        |   |                  |   |   |              |   |                  |   |        |   |                  |   |  |      |    |           |   |            |           |               |   |
| 4 PLC  | ±                                      |                                |   |       |       |       |       |   |       |   |        |    |        |   |  |          |   |        |   |                  |   |   |              |   |                  |   |        |   |                  |   |  |      |    |           |   |            |           |               |   |
| ANGLES   | ±1                                     |                                |   |       |       |       |       |   |       |   |        |    |        |   |  |          |   |        |   |                  |   |   |              |   |                  |   |        |   |                  |   |  |      |    |           |   |            |           |               |   |
| FINISH   | -                                      |                                |   |       |       |       |       |   |       |   |        |    |        |   |  |          |   |        |   |                  |   |   |              |   |                  |   |        |   |                  |   |  |      |    |           |   |            |           |               |   |
| MATERIAL   | -                                      |                                |   |       |       |       |       |   |       |   |        |    |        |   |  |          |   |        |   |                  |   |   |              |   |                  |   |        |   |                  |   |  |      |    |           |   |            |           |               |   |
| WEIGHT   | -                                      |                                |   |       |       |       |       |   |       |   |        |    |        |   |  |          |   |        |   |                  |   |   |              |   |                  |   |        |   |                  |   |  |      |    |           |   |            |           |               |   |
| CUSTOMER DRAWING   | -                                      |                                |   |       |       |       |       |   |       |   |        |    |        |   |  |          |   |        |   |                  |   |   |              |   |                  |   |        |   |                  |   |  |      |    |           |   |            |           |               |   |
| PRODUCT SPEC   | -                                      |                                |   |       |       |       |       |   |       |   |        |    |        |   |  |          |   |        |   |                  |   |   |              |   |                  |   |        |   |                  |   |  |      |    |           |   |            |           |               |   |
| APPLICATION SPEC   | -                                      |                                |   |       |       |       |       |   |       |   |        |    |        |   |  |          |   |        |   |                  |   |   |              |   |                  |   |        |   |                  |   |  |      |    |           |   |            |           |               |   |
| WEIGHT   | -                                      |                                |   |       |       |       |       |   |       |   |        |    |        |   |  |          |   |        |   |                  |   |   |              |   |                  |   |        |   |                  |   |  |      |    |           |   |            |           |               |   |
| CUSTOMER DRAWING   | -                                      |                                |   |       |       |       |       |   |       |   |        |    |        |   |  |          |   |        |   |                  |   |   |              |   |                  |   |        |   |                  |   |  |      |    |           |   |            |           |               |   |
| SIZE   | A2                                     |                                |   |       |       |       |       |   |       |   |        |    |        |   |  |          |   |        |   |                  |   |   |              |   |                  |   |        |   |                  |   |  |      |    |           |   |            |           |               |   |
| CAGE CODE  | -                                      |                                |   |       |       |       |       |   |       |   |        |    |        |   |  |          |   |        |   |                  |   |   |              |   |                  |   |        |   |                  |   |  |      |    |           |   |            |           |               |   |
| DRAWING NO   | C-2342891                              |                                |   |       |       |       |       |   |       |   |        |    |        |   |  |          |   |        |   |                  |   |   |              |   |                  |   |        |   |                  |   |  |      |    |           |   |            |           |               |   |
| RESTRICTED TO  | -                                      |                                |   |       |       |       |       |   |       |   |        |    |        |   |  |          |   |        |   |                  |   |   |              |   |                  |   |        |   |                  |   |  |      |    |           |   |            |           |               |   |
| SCALE 1:1  |  |                                | SHEET 2 OF 5  | REV A |       |       |       |   |       |   |        |    |        |   |  |          |   |        |   |                  |   |   |              |   |                  |   |        |   |                  |   |  |      |    |           |   |            |           |               |   |

THIS DRAWING IS UNPUBLISHED. RELEASED FOR PUBLICATION 20  
 © COPYRIGHT 20 BY - ALL RIGHTS RESERVED.

| REVISIONS |     |             |      |      |
|-----------|-----|-------------|------|------|
| P         | LTR | DESCRIPTION | DATE | APVD |
| -         | -   | SEE SHEET 1 | -    | -    |
|           |     |             |      |      |
|           |     |             |      |      |

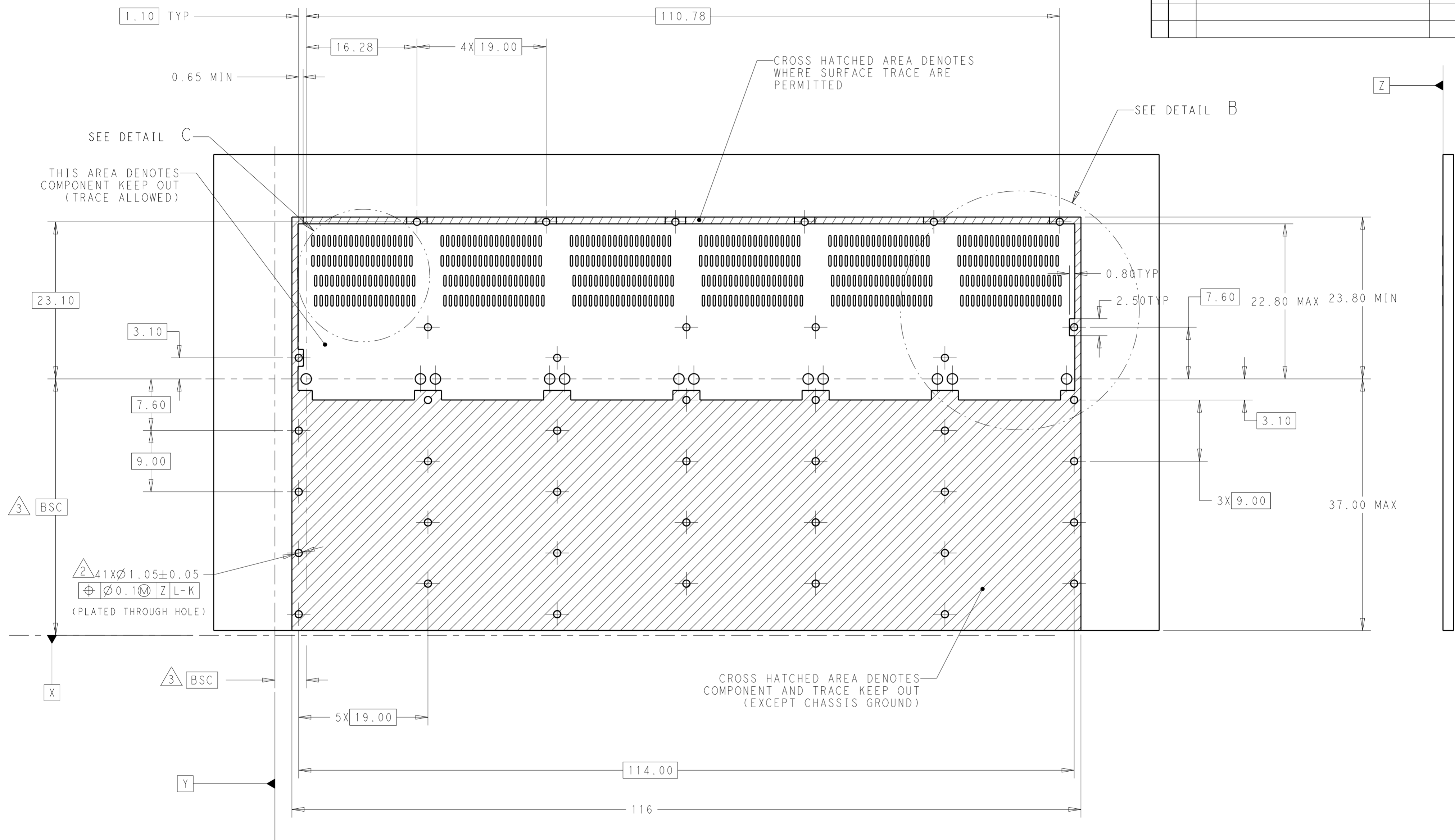

RECOMMENDED PCB LAYOUT  
 SINGLE TYPE  
 COMPONENT SIDE VIEW

|  |  |  |   |                         |
|--|--|--|---|-------------------------|
| THIS DRAWING IS A CONTROLLED DOCUMENT. |  | DWN<br>STEPHEN HE<br>23AUG2018   | TE Connectivity   |                         |
|  |  | CHK<br>SEAN HAN<br>23AUG2018   |   |                         |
|  |  | APVD<br>SEAN HAN<br>23AUG2018  | NAME<br>CAGE ASSEMBLY WIHT HEAT SINK FOR GM<br>QSFP-DD 1X6 ZIPPER |                         |
| DIMENSIONS:<br>mm                      |  | TOLERANCES UNLESS OTHERWISE SPECIFIED:   |   | PRODUCT SPEC<br>-       |
|  |  | 0 PLC ±0.25<br>1 PLC ±0.25<br>2 PLC ±0.25<br>3 PLC ±<br>4 PLC ±<br>ANGLES ±1<br>FINISH - |   | APPLICATION SPEC<br>-   |
| MATERIAL<br>-                          |  | WEIGHT<br>-  |   | SIZE<br>A2              |
|  |  | CUSTOMER DRAWING   |   | CAGE CODE<br>-          |
|  |  | SCALE 1:1  |   | DRAWING NO<br>C-2342891 |
|  |  | SHEET 3 OF 5   |   | RESTRICTED TO<br>-      |
|  |  | REV A  |   |                         |

THIS DRAWING IS UNPUBLISHED. RELEASED FOR PUBLICATION 20  
 © COPYRIGHT 20 BY - ALL RIGHTS RESERVED.

| REVISIONS |     |             |      |      |
|-----------|-----|-------------|------|------|
| P         | LTR | DESCRIPTION | DATE | APVD |
| -         | -   | SEE SHEET 1 | -    | -    |
|           |     |             |      |      |
|           |     |             |      |      |

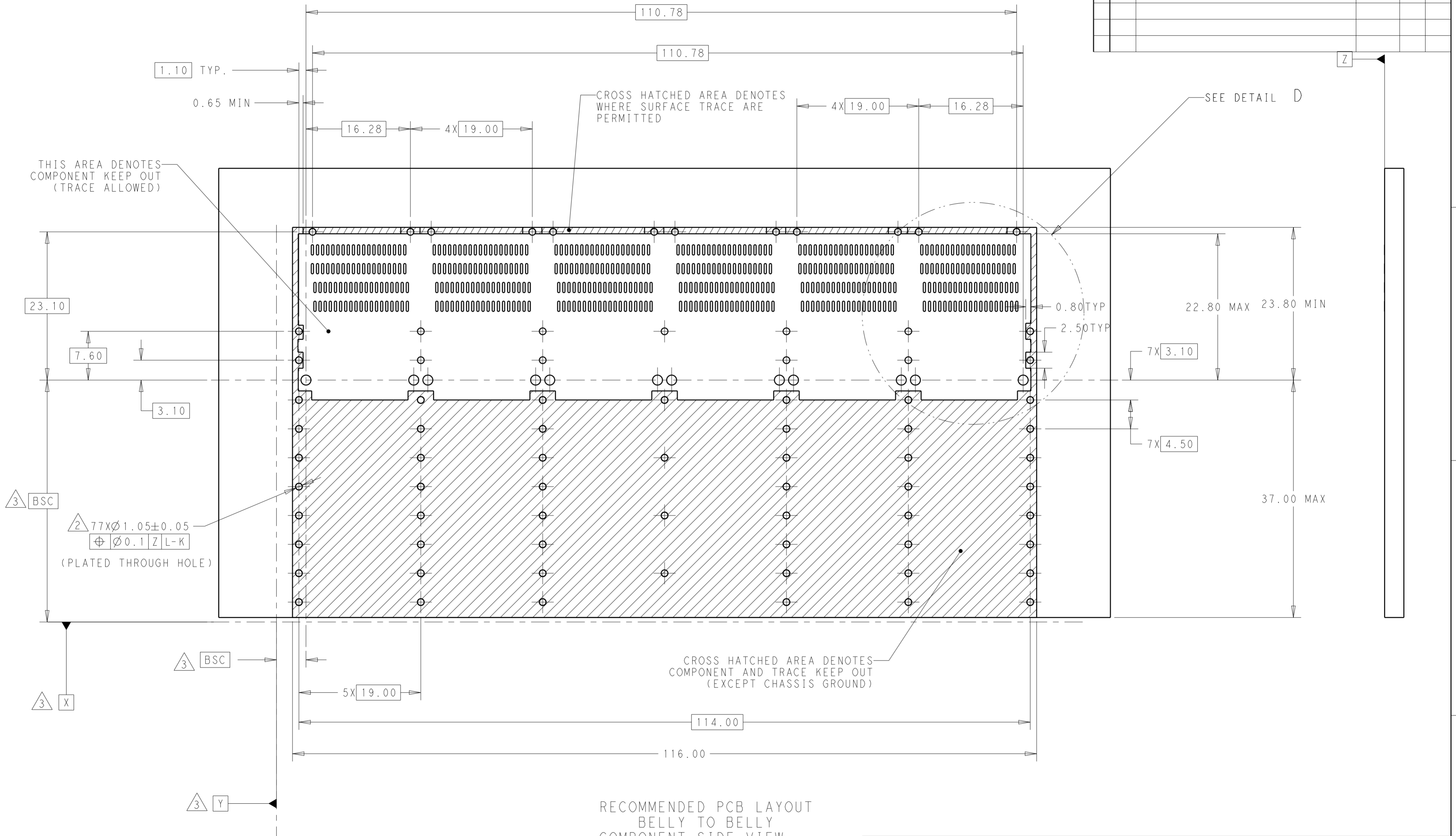

RECOMMENDED PCB LAYOUT  
 BELLY TO BELLY  
 COMPONENT SIDE VIEW

|  |  |                                |   |  |
|--|--|--------------------------------|---|--|
| THIS DRAWING IS A CONTROLLED DOCUMENT. |  | DWN<br>STEPHEN HE<br>23AUG2018 | TE Connectivity   |  |
| DIMENSIONS:<br>mm                      |  | CHK<br>SEAN HAN<br>23AUG2018   |   |  |
| TOLERANCES UNLESS OTHERWISE SPECIFIED: |  | APVD<br>SEAN HAN<br>23AUG2018  | NAME<br>CAGE ASSEMBLY WIHT HEAT SINK FOR GM<br>QSFP-DD 1X6 ZIPPER |  |
| 0 PLC ±0.25                            |  | PRODUCT SPEC                   | SIZE CAGE CODE DRAWING NO RESTRICTED TO                           |  |
| 1 PLC ±0.25                            |  | APPLICATION SPEC               | A2 - C-2342891  |  |
| 2 PLC ±0.25                            |  | WEIGHT                         | SCALE 1:1 SHEET 4 OF 5 REV A                                      |  |
| 3 PLC ±                                |  | CUSTOMER DRAWING               |   |  |
| 4 PLC ±                                |  |                                |   |  |
| ANGLES ±1                              |  |                                |   |  |
| FINISH                                 |  |                                |   |  |

THIS DRAWING IS UNPUBLISHED. RELEASED FOR PUBLICATION 20  
 © COPYRIGHT 20 BY - ALL RIGHTS RESERVED.

| REVISIONS |     |             |      |      |
|-----------|-----|-------------|------|------|
| P         | LTR | DESCRIPTION | DATE | APVD |
| -         | -   | SEE SHEET 1 | -    | -    |
|           |     |             |      |      |
|           |     |             |      |      |

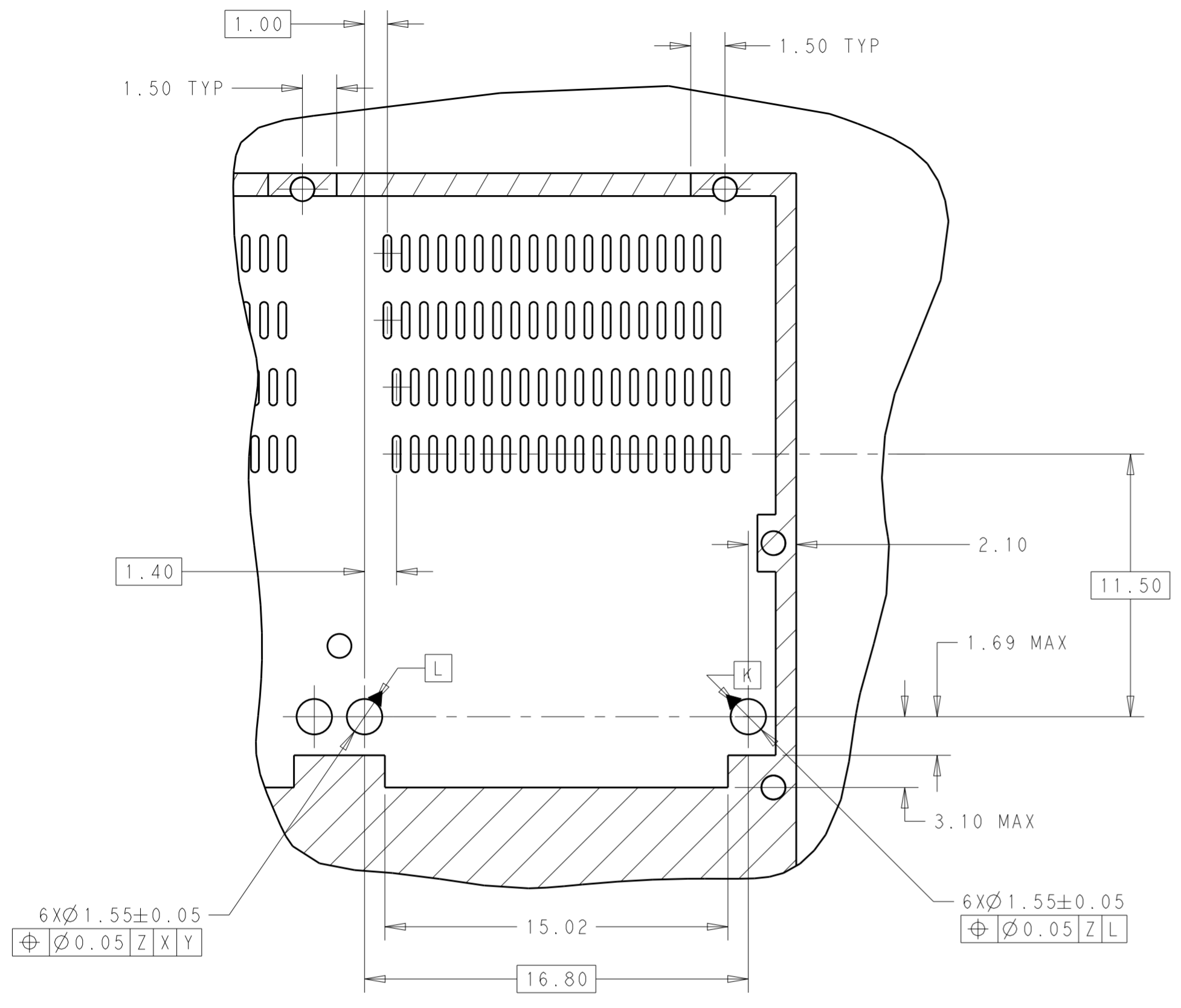

DETAIL B  
SCALE 5:1

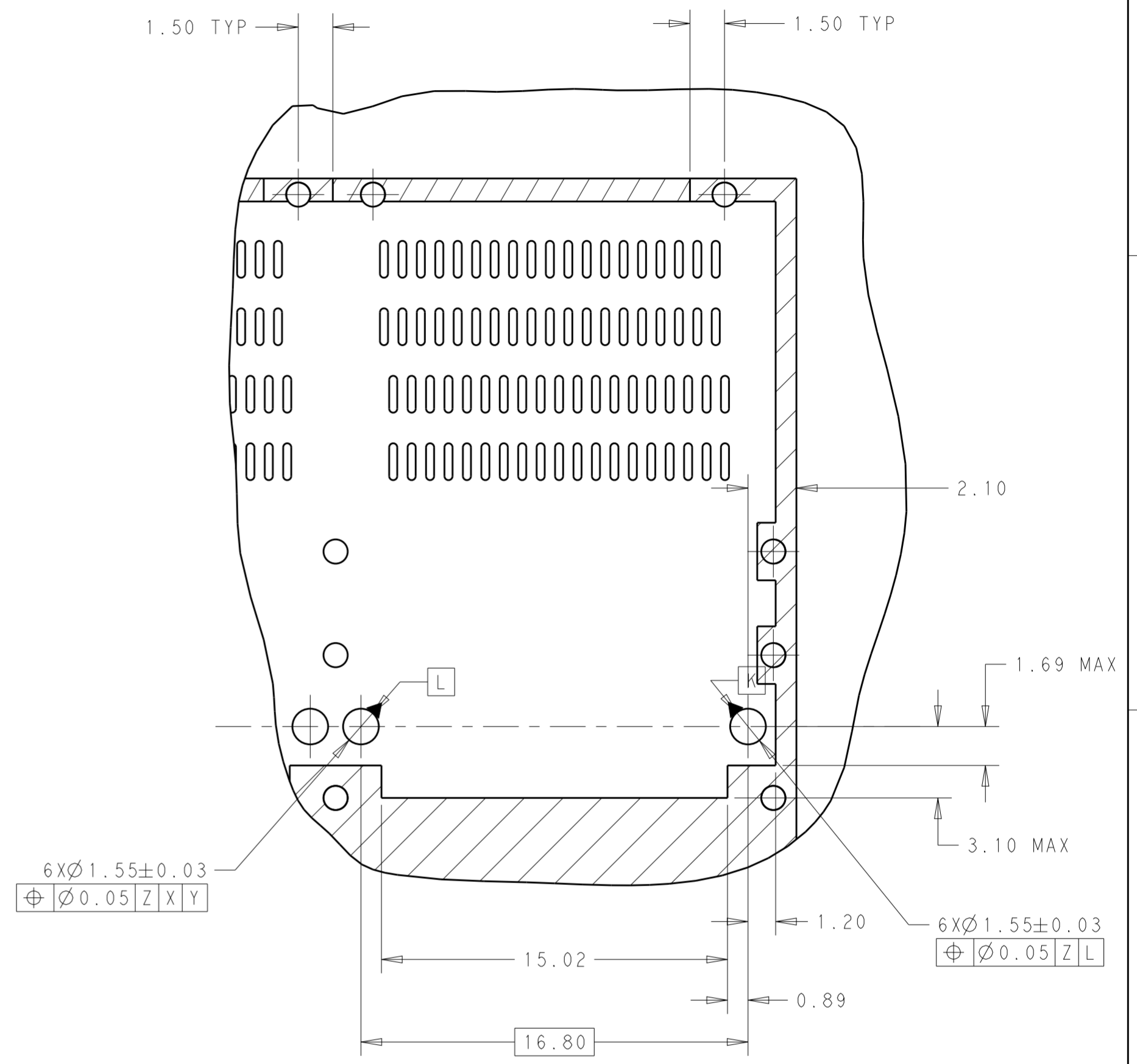

DETAIL D  
SCALE 5:1

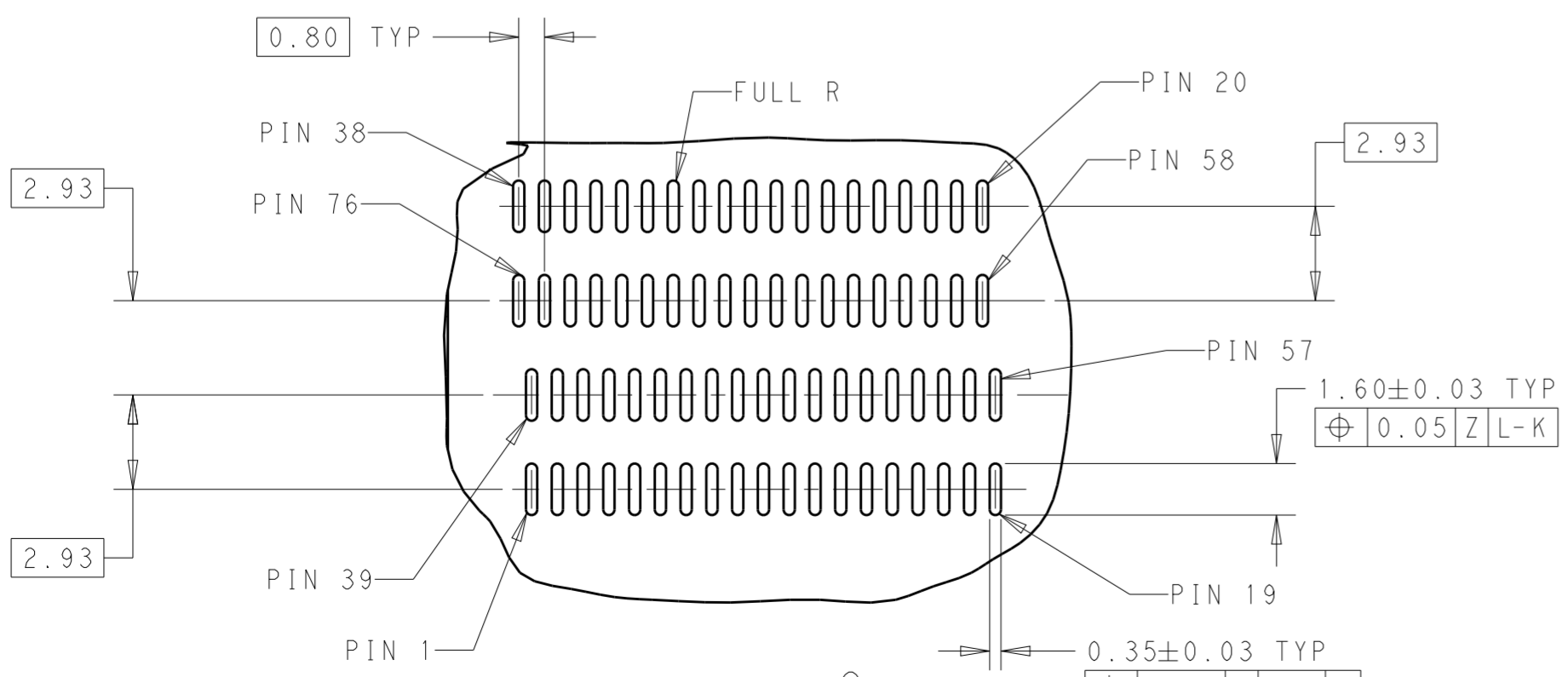

DETAIL C  
SCALE 5:1

|  |  |                                |                 |   |                  |                         |
|--|--|--------------------------------|-----------------|---|------------------|-------------------------|
| THIS DRAWING IS A CONTROLLED DOCUMENT.   |  | DWN<br>STEPHEN HE<br>23AUG2018 | TE Connectivity | NAME<br>CAGE ASSEMBLY WIHT HEAT SINK FOR GM<br>QSFP-DD 1X6 ZIPPER |                  |                         |
| DIMENSIONS:<br>mm  |  | CHK<br>SEAN HAN<br>23AUG2018   |                 | SIZE<br>A2  | CAGE CODE<br>-   | DRAWING NO<br>C-2342891 |
| TOLERANCES UNLESS OTHERWISE SPECIFIED:<br>0 PLC ±0.25<br>1 PLC ±0.25<br>2 PLC ±0.25<br>3 PLC ±<br>4 PLC ±<br>ANGLES ±1<br>FINISH - |  | APVD<br>SEAN HAN<br>23AUG2018  |                 | RESTRICTED TO<br>-  | SCALE<br>1:1     | SHEET<br>5 OF 5         |
| MATERIAL<br>-  |  | PRODUCT SPEC<br>-              |                 | WEIGHT<br>-   | CUSTOMER DRAWING | REV<br>A                |