

PRODUCT NUMBER
SEE TABLE

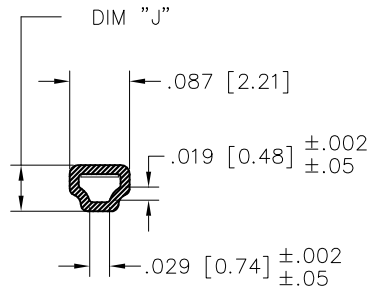

SECTION A-A

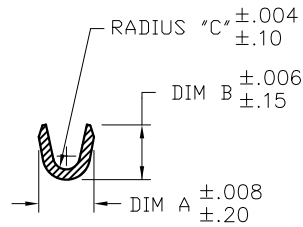

SECTION B-B
(N.T.S.)

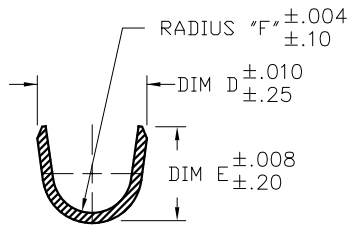

SECTION C-C
(N.T.S.)

SIDES OF SPRING MAY NOT
EXTEND BEYOND SIDE OF
TERMINAL MORE THAN .004/.10

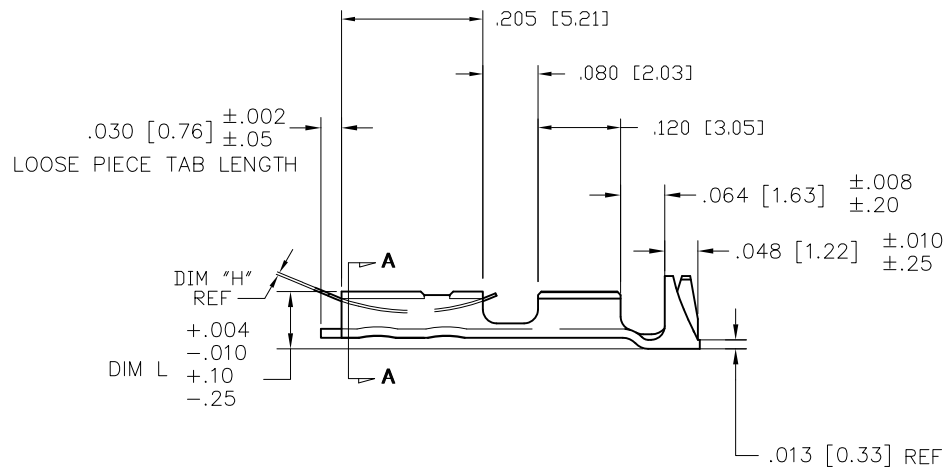
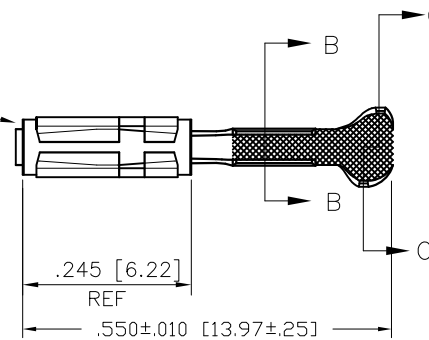

mat'l. code				surface	tolerance	projection	product family
SEE TABLE							PV TERMINALS
ltr	ecn no	dr	date	tolerances unless otherwise specified		INCH/MM	title
AA	v08-0113	HTB	2008-03-28	angles	.XX±.01/.X±.3		MAXI PV™ RECEPTACLE CRIMP TO WIRE
AB	v08-0510	HTB	2008-12-02	linear	.XXX±.005/.XX±.13		
AC	v11-0038	HTB	2011-10-11		.XXXX±.0020/.XXX±.051		
				dr	T. BREWBAKER	2006-04-18	sheet 1 of 3
W	v06-0218	HTB	2006-03-07	engr	T. BREWBAKER	2006-04-18	size
X	v06-0303	HTB	2006-04-18	chr	T. BREWBAKER	2006-04-18	A3
Y	v07-0218	HTB	2007-03-16	appd	T. BREWBAKER	2006-04-18	
sheet	revision	AC	AC	AC			
index	sheet	1	2	3			



Copyright FCJ

PRODUCT NUMBER		AWG RANGE	MATERIAL AND PLATING		SPRING THICKNESS		BODY			
REELED	LOOSE PC.		BODY : 1/4 HD BRASS	SPRING : BE-CU HEAT TREATED	DIM H		DIM J		DIM L	
					ENGLISH	METRIC	ENGLISH	METRIC	ENGLISH	METRIC
46220-000	46224-000									
46230-000	46234-000									
46240-000	46244-000									
46221-000LF	46225-000LF	18-20	40μ"/1.02μm MIN GOLD OVER	GOLD FLASH	0.0058	0.147	0.067	1.70	0.083	2.11
46231-000LF	46235-000LF	22-26	50μ"/1.27μm MIN NICKLE IN		0.0058	0.147	0.067	1.70	0.083	2.11
46241-000	46245-000	28-32	OBS. CONTACT AREA (NOTE 4)		OBSOLETE					
46222-000LF	47418-000LF				OBSOLETE					
46232-000LF	47419-000LF				OBSOLETE					
46242-000	47420-000				OBSOLETE					
46223-000LF	47387-000LF				OBSOLETE					
46233-000LF	47384-000LF				OBSOLETE					
46243-000	47403-000				OBSOLETE					
46226-000LF	46227-000LF	18-20	40μ"/1.02μm MIN GOLD OVER	GOLD FLASH	0.0048	0.122	0.067	1.70	0.083	2.11
46236-000LF	46237-000LF	22-26	50μ"/1.27μm MIN NICKLE IN		0.0048	0.122	0.067	1.70	0.083	2.11
46246-000	46247-000	28-32	OBS. CONTACT AREA (NOTE 4)		OBSOLETE					
46228-000	46229-000				OBSOLETE					
46238-000	46239-000				OBSOLETE					
46248-000	46249-000				OBSOLETE					
46580-000	46581-000				OBSOLETE					
46590-000	46591-000				OBSOLETE					
46600-000	46601-000				OBSOLETE					
47388-000	47391-000				OBSOLETE					
47389-000	47392-000				OBSOLETE					
47390-000	47393-000				OBSOLETE					
47612-000					OBSOLETE					
47613-000					OBSOLETE					
47614-000					OBSOLETE					
47621-000					OBSOLETE					
47622-000					OBSOLETE					
47653-000					OBSOLETE					
47733-000					OBSOLETE					
47734-000					OBSOLETE					
47735-000					OBSOLETE					
47736-000	46582-000				OBSOLETE					
47737-000	46592-000				OBSOLETE					
47738-000	46602-000				OBSOLETE					
48188-000	48189-000				OBSOLETE					

SEE SHEET 3 FOR PRODUCTS WITH LEAD-FREE TIN PLATING.

mat'l. code SEE TABLE		surface ✓	tolerance	projection ⊕	product family PV TERMINALS
ltr	ecn no	dr	date	tolerances unless otherwise specified	title
AC				linear .XX±.01/.X±.3 linear .XXX±.005/.XX±.13 linear .XXXX±.0020/.XXX±.051	INCH/MM
					scale 1:1
		dr	T. BREWBAKER	2006-04-18	FCJ
		engr	T. BREWBAKER	2006-04-18	dwg no
		chr	T. BREWBAKER	2006-04-18	sheet 2 of 3
		appd	T. BREWBAKER	2006-04-18	size
sheet	revision				46220
index	sheet				A3
					type Product Customer Drawing

PRODUCT NUMBER		AWG RANGE	MATERIAL AND PLATING		SPRING THICKNESS		BODY					
REELED	LOOSE PC.		BODY : 1/4 HD BRASS		SPRING : BE-CU HEAT TREATED		DIM H		DIM J		DIM L	
46580-000LF	46581-000LF						ENGLISH	METRIC	ENGLISH	METRIC	ENGLISH	METRIC
46590-000LF	46591-000LF		OBSOLETE									
46600-000LF	46601-000LF											
47388-000LF	47391-000LF	18-20	HOT DIPPED TIN (NOTE 7)		TIN PLATED		0.0058	0.147	0.067	1.70	0.083	2.11
47389-000LF	47392-000LF	22-26					0.0058	0.147	0.067	1.70	0.083	2.11
47390-000LF	47393-000LF	28-32					0.0058	0.147	0.067	1.70	0.083	2.11
47736-000LF	46582-000LF	18-20	HOT DIPPED TIN (NOTE 7)		TIN PLATED		0.0048	0.122	0.067	1.70	0.083	2.11
47737-000LF	46592-000LF	22-26					0.0048	0.122	0.067	1.70	0.083	2.11
47738-000LF	46602-000LF	28-32					0.0048	0.122	0.067	1.70	0.083	2.11

AWG RANGE	WIRE BARREL						INSULATION BARREL									
	DIM A		DIM B		DIM C		INSULATION DIA. RANGE FOR DISCRETE TERMINALS		INSULATION DIA. RANGE WHEN USED WITH MAXI LATCH HSG.		DIM D		DIM E		DIM F	
	ENGLISH	METRIC	ENGLISH	METRIC	ENGLISH	METRIC	ENGLISH	METRIC	ENGLISH	METRIC	ENGLISH	METRIC	ENGLISH	METRIC	ENGLISH	METRIC
18-20	0.110	2.79	0.110	2.79	0.021	0.53	0.042 - 0.103	1.07 - 2.62	0.042 - 0.060	1.07 - 1.52	0.139	3.53	0.123	3.12	0.050	1.27
22-26	0.070	1.78	0.070	1.78	0.017	0.43	0.036 - 0.103	0.91 - 2.62	0.036 - 0.060	0.91 - 1.52	0.139	3.53	0.123	3.12	0.050	1.27
28-30	0.054	1.37	0.058	1.47	0.011	0.28	0.028 - 0.054	0.71 - 1.37	0.028 - 0.054	0.71 - 1.37	0.115	2.92	0.110	2.79	0.040	1.02

NOTES:

- FOR DIMENSIONS OF WIRE BARREL AND INSULATION BARREL SEE TABLE.
- PART TO MATE WITH $.025 \pm .002$ [0.64 ± 0.05] SQ. PIN.
- APPLICABLE SPECIFICATIONS:
 - BUS-12-096 : PRODUCT SPECIFICATION
 - TA-213 : CRIMP SPECIFICATION FOR TERMINALS USED WITH MAXI-LATCH HOUSINGS.
 - TA-356 : CRIMP SPECIFICATION FOR CONTACTS NOT USED IN HOUSINGS.
- FINISH TO BE AS SPECIFIED IN CONTACT AREA. REMAINDER OF TOP OF PART TO BE GOLD FLASH OVER 50μ " / 1.27μ m NICKEL. BACKSIDE OF TERMINALS PLATED WITH 30μ " / 0.76μ m NICKEL ONLY.
- PRODUCT MEETS EUROPEAN UNION DIRECTIVES AND OTHER COUNTRY REGULATIONS AS DESCRIBED IN GS-22-008.
- THIS PRODUCT IS NOT INTENDED TO BE EXPOSED TO MANUFACTURING SOLDER PROCESSES.
- THIS PRODUCT HAS 100% TIN PLATING IN THE INTERFACE AND HAS NOT BEEN TESTED FOR WHISKER GROWTH IN ALL INTERCONNECT ENVIRONMENTS.

mat'l. code SEE TABLE				surface <input checked="" type="checkbox"/>	tolerance	projection	product family PV TERMINALS
ltr	ecn no	dr	date	tolerances unless otherwise specified			title
AC				angles	linear	INCH/MM	MAXI PV™ RECEPTACLE CRIMP TO WIRE
						scale 1:1	
		dr	T. BREWBAKER	2006-04-18			sheet 3 of 3
		engr	T. BREWBAKER	2006-04-18			size A3
		chr	T. BREWBAKER	2006-04-18			dwg no 46220
		appd	T. BREWBAKER	2006-04-18			type Product Customer Drawing
sheet index	revision sheet						



Copyright FCJ