

PART NO. 92001-0057
 DWG. NO. SD-92001-103

BILL OF MATERIALS

NO.	QTY	SUPPLIER	DESCRIPTION	PART No.	NOTE
1	2	MOLEX	MINI FIT CONNECTOR HOUSING RECEPTACLE	39-01-2085	2
2	16	MOLEX	MINI FIT CONNECTOR CRIMP TERMINAL	39-00-0059	
3	8	MOLEX	18 AWG CABLE, UL - 1007 BLACK	99036-0158	3, 4
4	1	BRADY	LABEL	THT-9-427-10	4, 5
5	2	BRADY	LABEL	THT-11-423-10	2, 5
6	2	MOLEX	CABLE TIE	90848-0018	3

WIRING DIAGRAM:

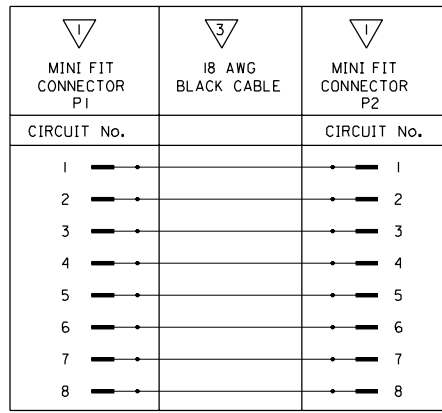

CABLE SPECIFICATION:

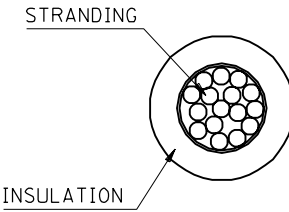

CONDUCTOR:	
- MATERIAL	STRANDED TINNED Cu.
- A.W.G	18
- STRANDING QTY/MM	16/0.25 OR 19/0.25
- DIAMETER	1.23
INSULATION:	
- MATERIAL	PVC
- MIN AVG WALL THICKNESS	0.39
- MIN WALL THICKNESS	0.34
- COLOUR	BLACK
- OUTSIDE DIAMETER	2.10±0.05
RATING:	
- STYLE	UL - 1007
- FLAME RATING	VW-1
- VOLTAGE RATING	300 V
- OPERATING TEMPERATURE	80°

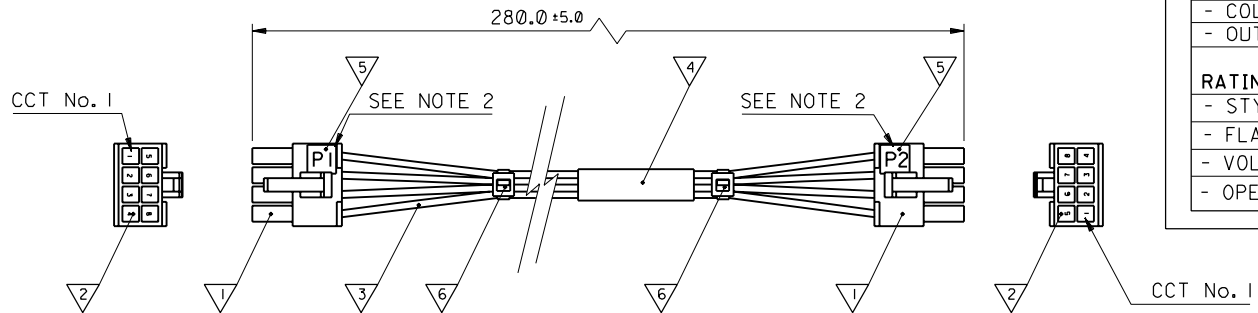

- NOTES:**
- HARNESS TO BE 100% ELECTRICALLY TESTED.
 - PLACE LABELS P1 & P2 ON CONNECTORS AS SHOWN ABOVE.
 - TIE WRAPS TO BE EQUALLY SPACED AS REQUIRED TO ENSURE PROPER CABLE BUNDLING.
 - THE FOLLOWING INFORMATION HAS TO BE PRINTED ON THE LABEL AND PLACED ON THE CABLE WHERE SHOWN: P/N - 530-2443-01, REV - 50, VENDOR CODE - M02451, DATE CODE - WEEK No. AND YEAR eg. 0899 AND Assembled In Slovakia.
 - SUPPLIER OR CUSTOMER APPROVED EQUIVALENT.
 - PACKAGING: PARTS ARE TO BE PACKED 5 PER BAG.
 - ATTACH UL LABEL TO EVERY BOX.

ORIGINAL RELEASE EC NO. E90340 DRWN: D.RYAN 99/04/15 CHK: / / / / APPR: / / / /	DESCRIPTION MAJOR = CRITICAL = C =	QUALITY SYMBOLS	GENERAL TOLERANCES: (UNLESS SPECIFIED)		SCALE 1 : 1	DESIGN UNITS <input checked="" type="checkbox"/> mm <input type="checkbox"/> INCH	THIRD ANGLE PROJECTION <input type="checkbox"/> mm <input type="checkbox"/> INCH <input checked="" type="checkbox"/> mm ONLY	SHT	REV
			4 PLACES ±0. mm ±. INCH	3 PLACES ±0. mm ±. INCH				2 PLACES ±0. mm ±. INCH	1 PLACE ±0. mm ±. INCH
CAD FILENAME S9200157.DGN			MATERIAL NO. 92001-0057		DRAWING NO. SD-92001-103		SHEET NO. 1 OF 1		SIZE B

THIS DRAWING CONTAINS INFORMATION THAT IS PROPRIETARY TO MOLEX INCORPORATED AND SHOULD NOT BE USED WITHOUT WRITTEN PERMISSION.