

DESCRIPTION

Demonstration circuit 1446 features the LTC6909 multiple output oscillator with spread spectrum frequency modulation (SSFM). The LTC6909 is an easy to use precision oscillator that can provide 1-, 2-, 3-, 4-, 5-, 6-, 7- or 8-phase synchronized outputs. The LTC6909 spread spectrum frequency modulation (SSFM), can be enabled to improve electromagnetic compatibility (EMC) performance. Eight separate outputs provide up to eight rail-to-rail, 50% duty cycle clock signals. Using three logic inputs, the outputs are configured for phase separation, ranging from 45° to 120° (three to eight phases). The clock outputs can also be held low or configured for Hi-Z. A single resistor (RSET) combined with the phase configuration, sets the output frequency, based on the following formula:

$$f_{OUT} = (20\text{MHz} \times 10\text{k}) / (\text{RSET} \times \text{PH})$$

where PH = 3, 4, 5, 6, 7 or 8
 the f_{OUT} range is 12.5kHz to 6.67MHz.

The PH0, PH1 and PH2 logic inputs define the LTC6909 multi-phase mode of operation and control its outputs as follows:

PH2	PH1	PH0	MODE
0	0	0	All Outputs Are Floating (Hi-Z)
0	0	1	All Outputs Are Held Low
0	1	0	3-Phase Mode (PH = 3)
0	1	1	4-Phase Mode (PH = 4)
1	0	0	5-Phase Mode (PH = 5)
1	0	1	6-Phase Mode (PH = 6)
1	1	0	7-Phase Mode (PH = 7)
1	1	1	8-Phase Mode (PH = 8)

A DC1446 contains an LTC6909 and test terminals for the eight outputs. On board jumpers are provided to set the LTC6909 phase inputs (PH0, PH1 and PH2) and the SSFM modulation. The on board frequency setting resistor (RSET) is pre-loaded with a 100k surface mount resistor (in addition, two pin receptacles are provided for using a leaded RSET resistor).

Design files for this circuit board are available.

Call the LTC factory.

LTC, LT are registered trademarks of Linear Technology Corporation.

QUICK START PROCEDURE

Demonstration circuit 1446 is easy to set up and test. Refer to Figure 1 for the quick test setup and follow the procedure below:

1. Place jumpers in the following positions:

JP3 (PH0) to V+, JP4 (PH1) to V+, JP1 (PH2) to V+ and JP1 (MOD) to SSFM OFF.

2. Set the power supply to 5V.

3. Turn on the power supply.

4. With a 10x probe connected to OUT1 the oscilloscope should show a 5V, 250kHz, squarewave ($\pm 4.5\%$).

DEMO CIRCUIT 1446 QUICK START GUIDE - LTC6909 3 TO 8 OUTPUT MULTIPHASE OSCILLATOR WITH SSFM

QUICK START SET-UP

Figure 1. Quick Test Setup

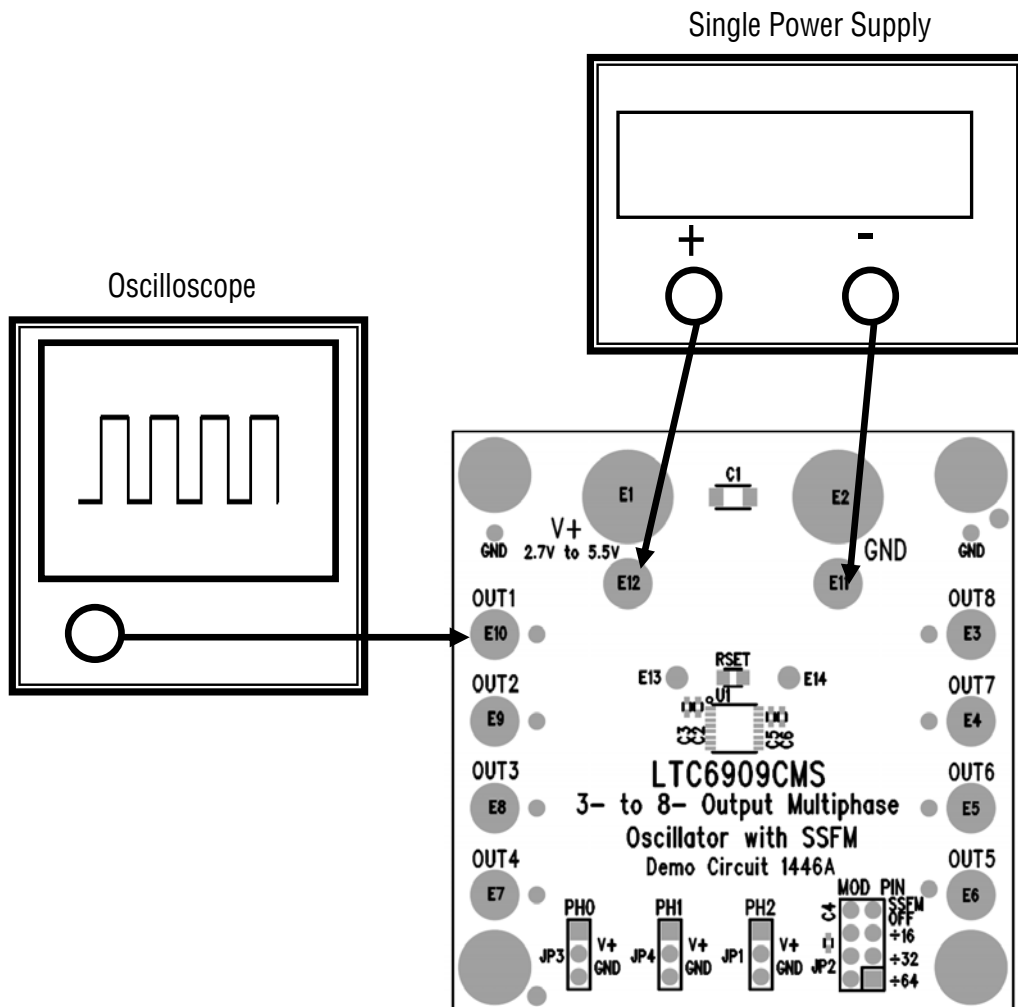

NOTE: The 6909 outputs (OUT1-OUT8) can drive 1k and 50pF loads. If a spectrum analyzer is used to measure the spread spectrum bandwidth then use a high impedance probe to monitor the outputs (typically the input impedance of a spectrum analyzer is 50 ohms).

DEMO CIRCUIT 1446 QUICK START GUIDE - LTC 6909 3 TO 8 OUTPUT MULTIPHASE OSCILLATOR WITH SSFM

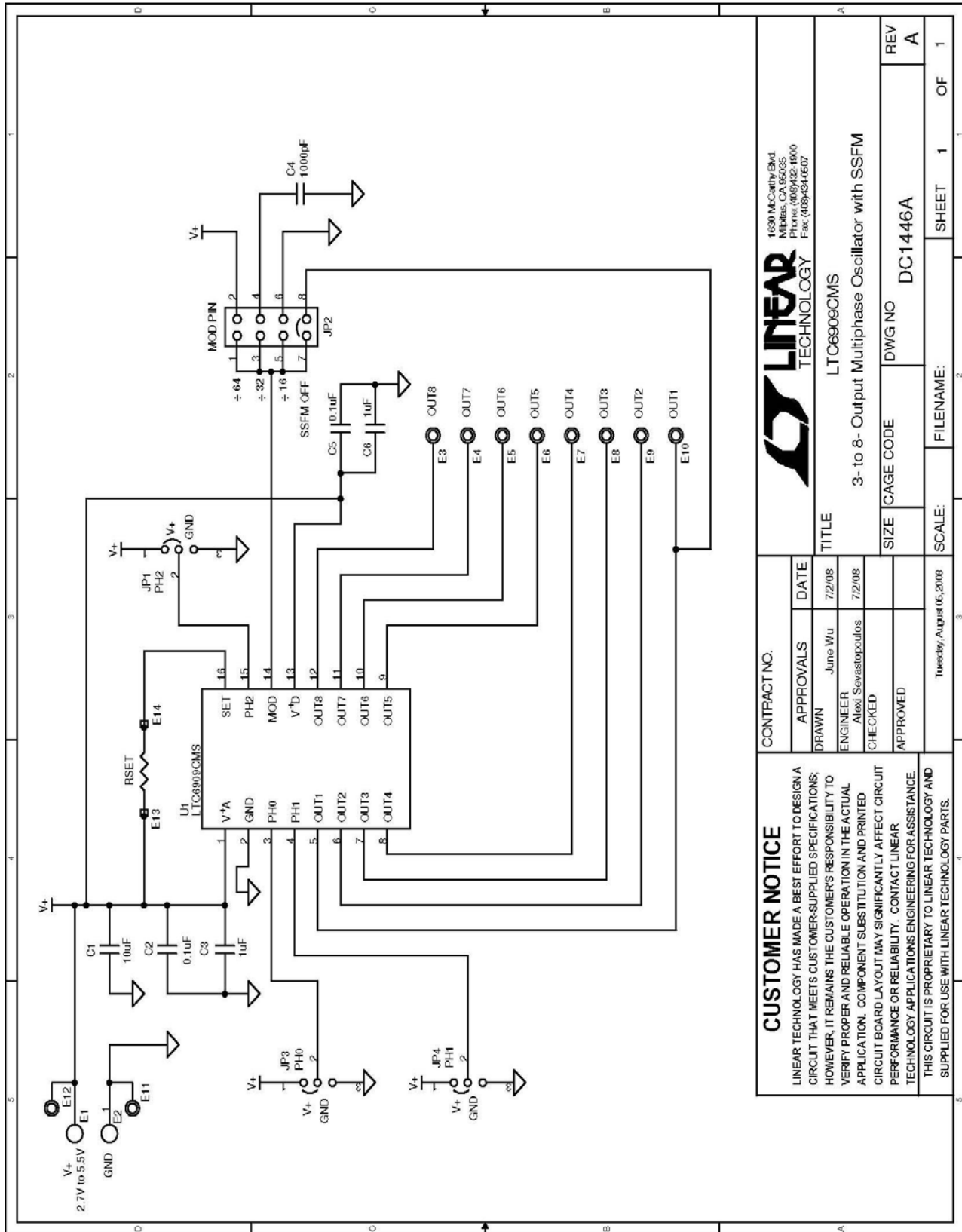

CONTRACT NO.		APPROVALS		DATE	
		DRAWN June Wu		7/2/08	
		ENGINEER Alexi Sevastopoulos		7/2/08	
		CHECKED			
		APPROVED			
		Tuesday, August 05, 2008			
CUSTOMER NOTICE		<p>LINEAR TECHNOLOGY HAS MADE A BEST EFFORT TO DESIGN A CIRCUIT THAT MEETS CUSTOMER-SUPPLIED SPECIFICATIONS; HOWEVER, IT REMAINS THE CUSTOMER'S RESPONSIBILITY TO VERIFY PROPER AND RELIABLE OPERATION IN THE ACTUAL APPLICATION. COMPONENT SUBSTITUTION AND PRINTED CIRCUIT BOARD LAYOUT MAY SIGNIFICANTLY AFFECT CIRCUIT PERFORMANCE OR RELIABILITY. CONTACT LINEAR TECHNOLOGY APPLICATIONS ENGINEERING FOR ASSISTANCE. THIS CIRCUIT IS PROPRIETARY TO LINEAR TECHNOLOGY AND SUPPLIED FOR USE WITH LINEAR TECHNOLOGY PARTS.</p>			
LINEAR TECHNOLOGY		LTC6909CMS		TITLE	
1630 McCarthy Blvd. Milpitas, CA 95035 Phone: (408)432-1900 Fax: (408)434-6507		3- to 8- Output Multiphase Oscillator with SSFM		REV A	
SIZE		CAGE CODE		DWG NO	
SCALE:		FILENAME:		SHEET 1 OF 1	

DEMO CIRCUIT 1446 QUICK START GUIDE - LTC 6909 3 TO 8 OUTPUT MULTIPHASE OSCILLATOR WITH SSFM

DC1446 PARTS LIST

<i>Item</i>	<i>Qty</i>	<i>Reference</i>	<i>Part Description</i>	<i>Manufacturer / Part #</i>
1	1	C1	CAP., X7R, 10uF, 10V, 20% 1206	AVX, 1206ZC106MAT2A
2	2	C5,C2	CAP., X7R, 0.1uF, 16V, 10% 0402	TDK, C1005X7R1C104K
3	2	C3,C6	CAP., X5R, 1uF, 6.3V, 10% 0402	TDK, C1005X5R0J105K
4	1	C4	CAP., C0G, 1000pF, 25V, 5% 0402	TDK, C1005C0G1E102J
5	2	E1,E2	JACK, BANANA	KEYSTONE, 575-4
6	10	E3-E12	TESTPOINT, TURRET, .094" pbf	MILL-MAX, 2501-2-00-80-00-00-07-0
7	3	JP1,JP3,JP4	3 PIN 0.079 SINGLE ROW HEADER	SAMTEC, TMM103-02-L-S
8	1	JP2	2X4, 0.079 DOUBLE ROW HEADER	SAMTEC, TMM104-02-L-D
9	4	xJP1-xJP4	SHUNT, .079" CENTER	SAMTEC, 2SN-BK-G
10	0	RSET(open)	Res., 0805	
11	2	E13,E14	Pin, 0.057 hole	Mill-Max, 8427-0-15-15-30-84-04-0
12	1	U1	IC., LTC6909CMS, MSOP-16	Linear Tech., LTC6909CMS
13	4	(STAND-OFF)	STAND-OFF, NYLON 0.375"	KEYSTONE, 8832(SNAP ON)