

DO NOT SCALE FROM THIS PRINT

DESIGNED & DIMENSIONED IN MILLIMETERS [INCHES]

ERF8-XXX-XX.X-XXX-DV-XXXX-XX

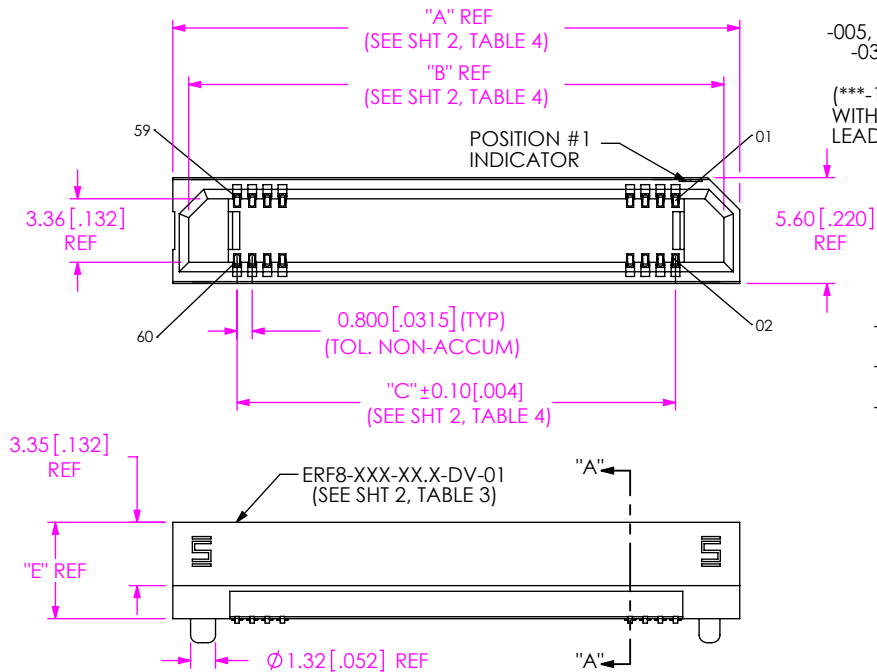

No OF POSITIONS (PER ROW)

-005, -010, -011, -013, -020, -023, -025, -030, -035, -040, -049, -050, -060, -070, -075, \*\*\*-100  
 (\*\*\*)-100 POSITION NOT AVAILABLE WITH OPTIONS -L, -EGP & -EGPS OR LEAD STYLES -07.0, -09.0 & -10.0)

LEAD STYLE

-05.0 = 5mm  
 -07.0 = 7mm  
 -09.0 = 9mm (SEE FIG 10 & 11)  
 \*\*-10.0 = 10mm (SEE FIG 7)

PLATING SPECIFICATION

-L: 10µ" SELECTIVE GOLD IN CONTACT AREA, MATTE TIN ON TAIL  
 -S: 30µ" SELECTIVE GOLD IN CONTACT AREA, MATTE TIN ON TAIL  
 -STL: 30µ" SELECTIVE GOLD IN CONTACT AREA, TIN/LEAD (90/10+/-5%) TAIL

ROW SPECIFICATION

-DV: DOUBLE VERTICAL

PACKAGING

-TR: TAPE & REEL (SEE NOTE 11 & 13)  
 -FR: FULL REEL QTY. TAPE & REEL (SEE NOTE 11 & 13)  
 -LEAVE BLANK FOR TRAY: (SEE NOTE 7)

OPTION

-L: LATCHES (-05.0, -07.0 & -09.0 LEAD STYLE ONLY, SEE NOTE 5, SEE FIG 5 & 11)  
 -S: SHIELD (-05.0 & -07.0 LEAD STYLE ONLY, -010, -020, -025, -030 POS ONLY, SEE FIG 9)  
 -EGP: EXTENDED GUIDE POST (SEE NOTE 6, SEE FIG 3)  
 -EGPS: EXTENDED GUIDE POST SHIELD (ONLY AVAILABLE IN -07.0 LEAD STYLE AND ONLY -010, -020, -025 & -030 POSITIONS (SEE NOTE 6, 10 & FIG 6)  
 -K: POLYIMIDE FILM PAD (SEE FIG 2)

\*\* = NOT TOOLED

No. OF POS.	
-005, -010, -011, -013, -020, -025, -023 -030	0.10 [0.004]
-035, -040, -049, -050, -060	0.12 [0.005]
-070, -075, ***-100	0.15 [0.006]

ERF8 LEAD STYLE	ERM8 LEAD STYLE				
	-02.0	-05.0	-08.0	-09.0	-15.0
-05.0	7.0MM	10.0MM	13.0MM	14.0MM	20.0MM
-07.0	9.0MM	12.0MM	15.0MM	16.0MM	22.0MM
-07.0-L					
-09.0	11.0MM	14.0MM	17.0MM	18.0MM	24.0MM
-10.0	12.0MM	15.0MM	18.0MM	19.0MM	25.0MM

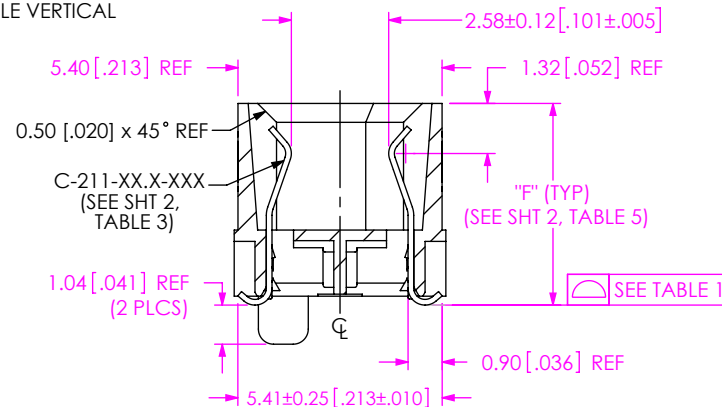
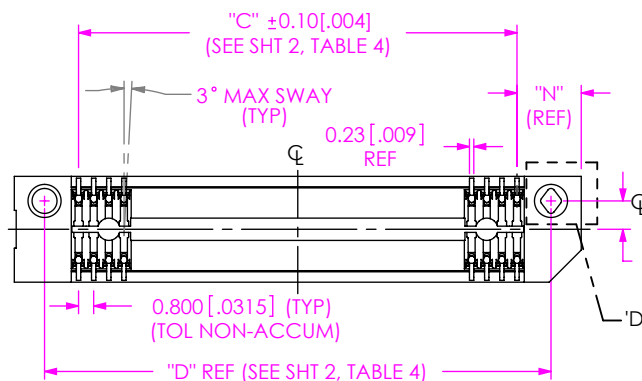

FIG 1 (ERF8-030-05.0-XXX-DV-XX SHOWN) (CENTER FEATURES REMOVED FOR CLARITY)

DETAIL 'D' SCALE 4 : 1

OPTION	"N"
NONE	3.40 [0.134]
-L, EGP	4.15 [0.163]

NOTES:

1. REPRESENTS A CRITICAL DIMENSION.
2. BURR ALLOWANCE: 0.038 [0.015] MAX.
3. MINIMUM PUSHOUT FORCE: 2.22 N [0.5 LB.]
4. NOTE DELETED.
5. NOT AVAILABLE WITH -EGP OR -EGPS OPTIONS.
6. OPTION ONLY AVAILABLE ON -07.0 LEAD STYLE; NOT AVAILABLE WITH -L OPTION.
7. TRAY PACKAGING AVAILABLE ON \*\*\*100 POSITION ONLY.
8. \*\*\*100 POSITION NOT AVAILABLE IN -TR OR -FR.
9. NOTE DELETED.
10. FOR EGPS-K-TR COMBINATIONS LEAVE THE ZERO OFF THE FRONT OF THE LEADSTYLE CALLOUT.
11. ORDERS WILL BE PACKAGED ACCORDING TO THE SAMTEC PACKAGING EFFICIENCY STANDARDS (SPES) FOUND ON WWW.SAMTEC.COM
12. ALL STYLES HAVE WELDS TABS AS STANDARD, EXCEPT THE -05 AND -07 LEAD STYLES (SEE TABLE 3).
13. ATTACH LABEL-4X2 TO EACH REEL.

UNLESS OTHERWISE SPECIFIED, DIMENSIONS ARE IN MILLIMETERS [INCHES]. TOLERANCES ARE:  
 DECIMALS ANGLES  
 X.X: ±0.3 [0.1]  
 X.XX: ±0.13 [0.005]  
 X.XXX: ±0.050 [0.0020]

PROPRIETARY NOTE  
 THIS DOCUMENT CONTAINS CONFIDENTIAL AND PROPRIETARY INFORMATION AND ALL DESIGN, MANUFACTURING, REPRODUCTION, USE, PATENT RIGHTS AND SALES RIGHTS ARE EXPRESSLY RESERVED BY SAMTEC, INC. THIS DOCUMENT SHALL NOT BE DISCLOSED, IN WHOLE OR PART, TO ANY UNAUTHORIZED PERSON OR ENTITY NOR REPRODUCED, TRANSFERRED OR INCORPORATED IN ANY OTHER PROJECT IN ANY MANNER WITHOUT THE EXPRESS WRITTEN CONSENT OF SAMTEC, INC.

MATERIAL: DO NOT SCALE DRAWING SHEET SCALE: 2:1  
 INSULATOR: VECTRA E-130I, UL94V-0 COLOR: BLACK  
 CONTACT & LATCHES: BeCu  
 SHIELD: PHOS BRONZE

DESCRIPTION:  
 0.8MM EDGE RATE SOCKET ASSEMBLY  
 DWG. NO.  
 ERF8-XXX-XX.X-XXX-DV-XXXX-XX  
 BY: KNOWLDEN 9/26/2005 SHEET 1 OF 7



520 PARK EAST BLVD, NEW ALBANY, IN 47150  
 PHONE: 812-944-6733 FAX: 812-948-5047  
 e-Mail: info@SAMTEC.com code 55322

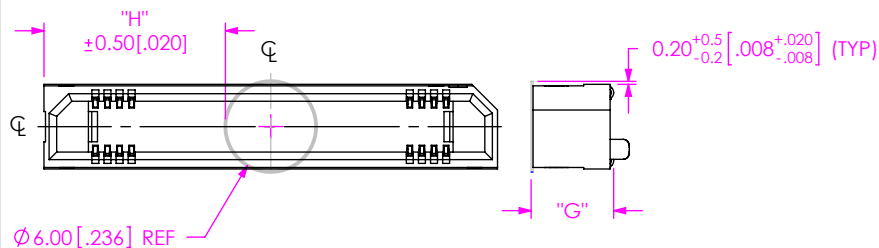
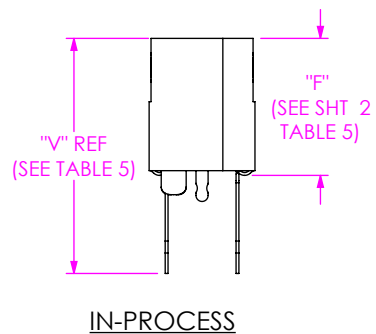

FIG 2  
-K OPTION  
(USE K-DOT-.236-.343-.005)  
(ERF8-030-XX.X-XXX-DV-K SHOWN)

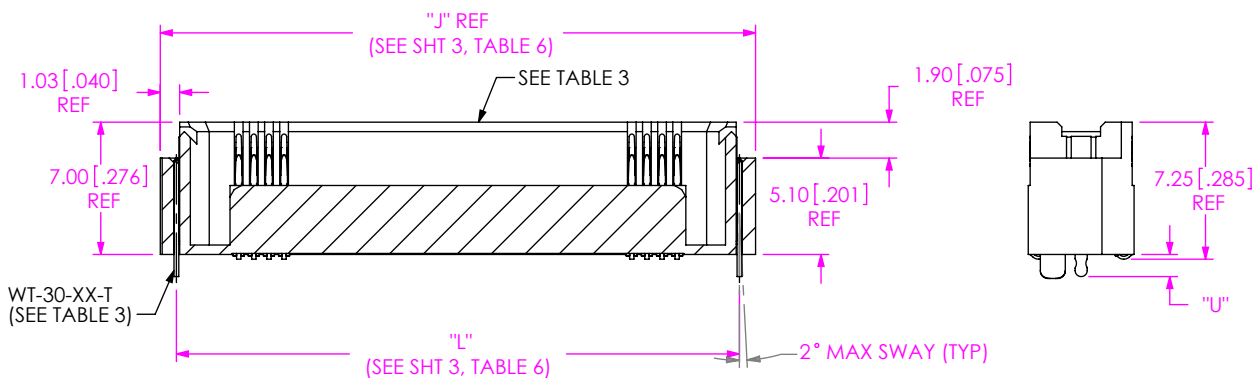
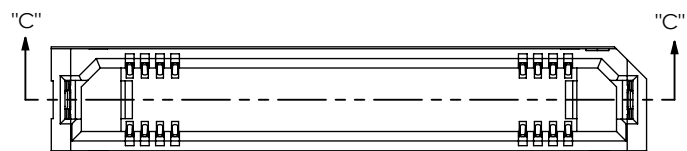
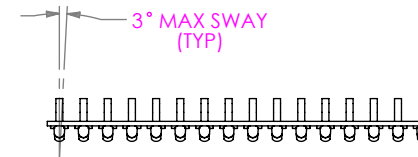

FIG 3  
-EGP OPTION  
(ERF8-030-07.0-XXX-DV-EGP SHOWN)  
(SAME AS FIG 1, EXCEPT AS SHOWN)  
(AVAILABLE ON -07.0 LEAD STYLE ONLY)  
(CENTER FEATURES REMOVED FOR CLARITY)

TABLE 4

POSITION	"A"	"B"	"C"	"D"	"H"
-005	10.00 [ .394]	8.32 [ .328]	3.20 [ .126]	6.80 [ .268]	2.00 [ .079]
-010	14.00 [ .551]	12.32 [ .485]	7.20 [ .283]	10.80 [ .425]	4.00 [ .157]
-011	14.80 [ .583]	13.12 [ .517]	8.00 [ .315]	11.60 [ .457]	4.40 [ .173]
-013	16.40 [ .646]	14.72 [ .580]	9.60 [ .378]	13.20 [ .520]	5.20 [ .205]
-020	22.00 [ .866]	20.32 [ .800]	15.20 [ .598]	18.80 [ .740]	8.00 [ .315]
-023	24.40 [ .961]	22.72 [ .894]	17.60 [ .693]	21.20 [ .835]	10.40 [ .409]
-025	26.00 [ 1.024]	24.32 [ .957]	19.20 [ .756]	22.80 [ .898]	10.00 [ .394]
-030	30.00 [ 1.181]	28.32 [ 1.115]	23.20 [ .913]	26.80 [ 1.055]	12.00 [ .472]
-035	34.00 [ 1.339]	32.32 [ 1.272]	27.20 [ 1.071]	30.80 [ 1.213]	14.00 [ .551]
-040	38.00 [ 1.496]	36.32 [ 1.423]	31.20 [ 1.228]	34.80 [ 1.370]	16.00 [ .630]
-049	45.20 [ 1.780]	43.52 [ 1.713]	38.40 [ 1.512]	42.00 [ 1.654]	19.60 [ .772]
-050	46.00 [ 1.811]	44.32 [ 1.745]	39.20 [ 1.543]	42.80 [ 1.685]	20.00 [ .787]
-060	54.00 [ 2.126]	52.32 [ 2.060]	47.20 [ 1.858]	50.80 [ 2.000]	24.00 [ .945]
-070	62.00 [ 2.441]	60.32 [ 2.375]	55.20 [ 2.173]	58.80 [ 2.315]	28.00 [ 1.102]
-075	66.00 [ 2.598]	64.32 [ 2.532]	59.20 [ 2.331]	62.80 [ 2.472]	30.00 [ 1.181]
***-100	86.00 [ 3.386]	84.32 [ 3.320]	79.20 [ 3.118]	82.80 [ 3.260]	40.00 [ 1.575]

TABLE 5

HEIGHT	"E"	"F"	"G"	"V"
-05.0	5.10 [ .201]	5.335 [ .2100]	5.52 [ .217]	10.525 [ .4144]
-07.0	7.00 [ .276]	7.250 [ .2854]	7.37 [ .290]	12.440 [ .4898]
-07.0-L				
-09.0	9.10 [ .358]	9.335 [ .3675]	9.52 [ .375]	14.525 [ .5719]
-10.0	10.10 [ .398]	10.335 [ .4069]	10.52 [ .414]	15.525 [ .6112]

TABLE 3

OPTION	STYLE	ERF8-XXX-XX.X-DV-XX	C-211-XX.X-XXX	WT/SH	"U"
NONE	-05.0	ERF8-XXX-05.0-DV-01	C-211-05.0-XXX	N.A.	N.A.
	-07.0	ERF8-XXX-07.0-DV-01	C-211-07.0-XXX		
	-09.0	ERF8-XXX-05.0-DV-S1/ ERF8H-XXX-04.0-DV	C-211-09.0-XXX	WT-30-08-F	1.64 [ .065]
	-10.0	ERF8-XXX-05.0-DV-S1/ ERF8H-XXX-05.0-DV	C-211-01.0-XXX	WT-67-02-T	1.64 [ .065]
-L	-05.0	ERF8-XXX-05.0-DV-L	C-211-05.0-XXX	WT-30-01-F	1.17 [ .046]
	-07.0	ERF8-XXX-07.0-DV-L	C-211-07.0-XXX	WT-30-09-F	1.65 [ .065]
	-09.0	ERF8-XXX-05.0-DV-S1/ ERF8H-XXX-04.0-DV	C-211-09.0-XXX	WT-30-10-F	1.64 [ .065]
-S	-05.0	ERF8-XXX-05.0-DV-S	C-211-05.0-XXX	SH29-XX-07-N	1.63 [ .064]
	-07.0	ERF8-XXX-07.0-DV-EGPS	C-211-07.0-XXX	SH29-XX-01-N	1.17 [ .046]
-EGP	-07.0	ERF8-XXX-07.0-DV-EGP	C-211-07.0-XXX	WT-30-02-T	1.17 [ .046]
-EGPS	-07.0	ERF8-XXX-07.0-DV-EGPS	C-211-07.0-XXX	SH29-XX-01-N	1.17 [ .046]

**PROPRIETARY NOTE**  
THIS DOCUMENT CONTAINS CONFIDENTIAL AND PROPRIETARY INFORMATION AND ALL DESIGN, MANUFACTURING, REPRODUCTION, USE, PATENT RIGHTS AND SALES RIGHTS ARE EXPRESSLY RESERVED BY SAMTEC, INC. THIS DOCUMENT SHALL NOT BE DISCLOSED, IN WHOLE OR IN PART, TO ANY UNAUTHORIZED PERSON OR ENTITY NOR REPRODUCED, TRANSMITTED OR INCORPORATED IN ANY OTHER PROJECT IN ANY MANNER WITHOUT THE EXPRESS WRITTEN CONSENT OF SAMTEC, INC.

**samtec**  
520 PARK EAST BLVD. NEW ALBANY, IN 47150  
PHONE: 812-944-6733 FAX: 812-948-5047  
e-Mail info@SAMTEC.com code 55322

DESCRIPTION:  
**0.8MM EDGE RATE SOCKET ASSEMBLY**

DWG. NO.  
**ERF8-XXX-XX.X-XXX-DV-XXXX-XX**

BY:KNOWL DEN 9/26/2005 SHEET 2 OF 7

DO NOT SCALE DRAWING  
SHEET SCALE: 2:1

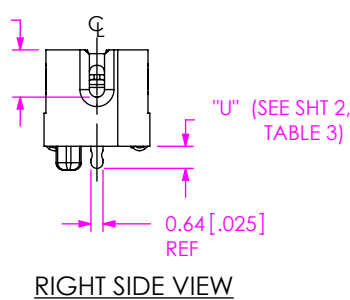
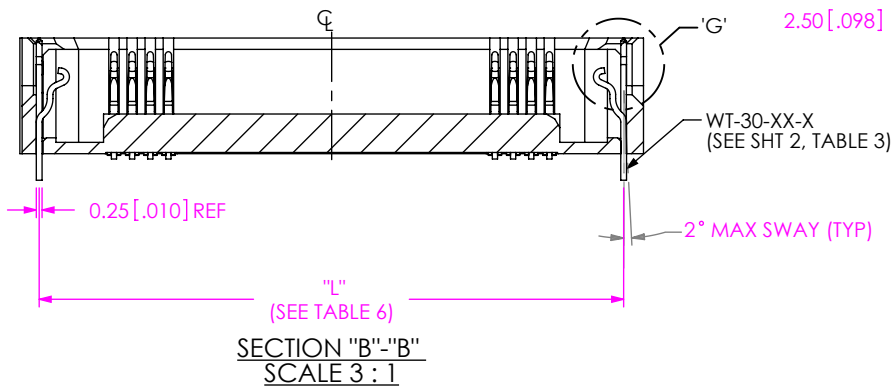
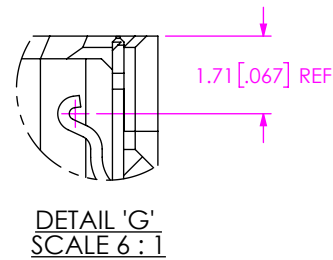
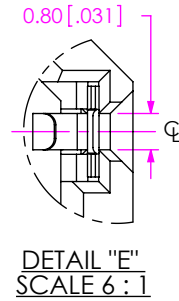
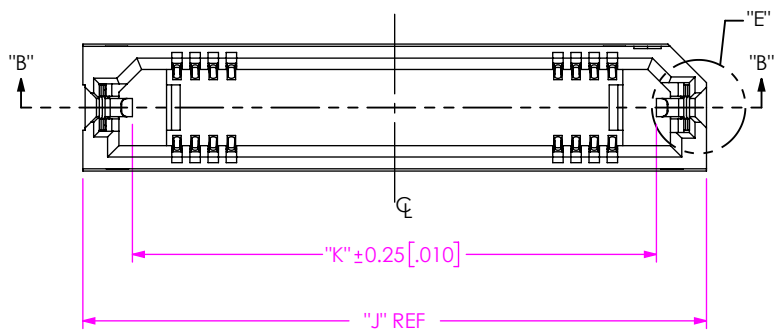

TABLE 6				
POSITION	"J"	"K"	"L" +/- 0.18 [007]	"M"
-005	11.50 [.453]	7.13 [.281]	9.80 [.386]	2.75 [.108]
-010	15.50 [.610]	11.13 [.438]	13.79 [.543]	4.75 [.187]
-011	16.30 [.642]	11.93 [.470]	14.61 [.575]	5.15 [.203]
-013	17.90 [.705]	13.53 [.533]	16.20 [.638]	5.95 [.234]
-020	23.50 [.925]	19.13 [.753]	21.79 [.858]	8.75 [.344]
-023	25.90 [1.020]	21.53 [.848]	24.21 [.953]	9.95 [.391]
-025	27.50 [1.083]	23.13 [.911]	25.81 [1.016]	10.75 [.423]
-030	31.50 [1.240]	27.13 [1.068]	29.79 [1.173]	12.75 [.502]
-035	35.50 [1.398]	31.13 [1.226]	33.78 [1.330]	14.75 [.581]
-040	39.50 [1.555]	35.13 [1.383]	37.80 [1.488]	16.75 [.659]
-049	46.70 [1.839]	42.33 [1.667]	45.00 [1.772]	20.35 [.801]
-050	47.50 [1.870]	43.13 [1.698]	45.80 [1.803]	20.75 [.817]
-060	55.50 [2.185]	51.13 [2.013]	53.80 [2.118]	24.75 [.974]
-070	63.50 [2.500]	59.13 [2.328]	61.80 [2.433]	28.75 [1.132]
-075	67.50 [2.657]	63.13 [2.485]	65.81 [2.591]	30.75 [1.211]

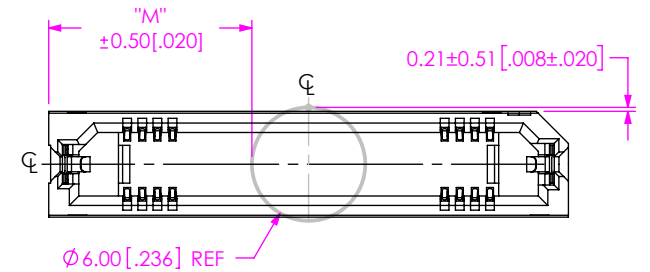

FIG 5  
(ERF8-025-05.0-XXX-DV-L-K SHOWN)  
(SAME AS FIG 1 & 2, EXCEPT AS SHOWN)  
(AVAILABLE ON -05.0 & -07.0 LEAD STYLE ONLY)  
(CENTER FEATURES REMOVED FOR CLARITY)

**PROPRIETARY NOTE**  
THIS DOCUMENT CONTAINS CONFIDENTIAL AND PROPRIETARY INFORMATION AND ALL DESIGN, MANUFACTURING, REPRODUCTION, USE, PATENT RIGHTS AND SALES RIGHTS ARE EXPRESSLY RESERVED BY SAMTEC, INC. THIS DOCUMENT SHALL NOT BE DISCLOSED, IN WHOLE OR PART, TO ANY UNAUTHORIZED PERSON OR ENTITY NOR REPRODUCED, TRANSFERRED OR INCORPORATED IN ANY OTHER PROJECT IN ANY MANNER WITHOUT THE EXPRESS WRITTEN CONSENT OF SAMTEC, INC.

DO NOT SCALE DRAWING

SHEET SCALE: 2:1



520 PARK EAST BLVD. NEW ALBANY, IN 47150  
PHONE: 812-944-6733 FAX: 812-948-5047  
e-Mail info@SAMTEC.com code 53322

DESCRIPTION:  
0.8MM EDGE RATE SOCKET ASSEMBLY

DWG. NO.  
ERF8-XXX-XX.X-XXX-DV-XXXX-XX

BY: KNOWLDEN 9/26/2005 SHEET 3 OF 7

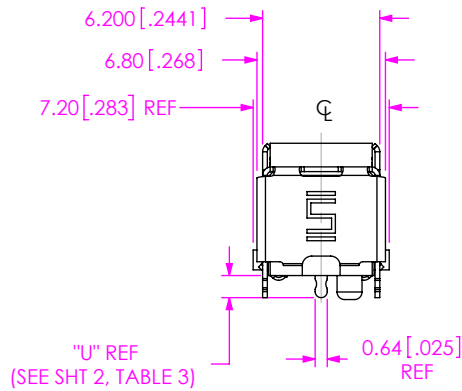

**FIG 6**  
(ERF8-030-07.0-XXX-DV-EGPS SHOWN)  
(SAME AS FIG 3, EXCEPT AS SHOWN)  
(AVAILABLE ON -07.0 LEAD STYLE ONLY)  
(CENTER FEATURES REMOVED FOR CLARITY)

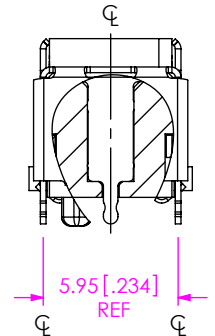
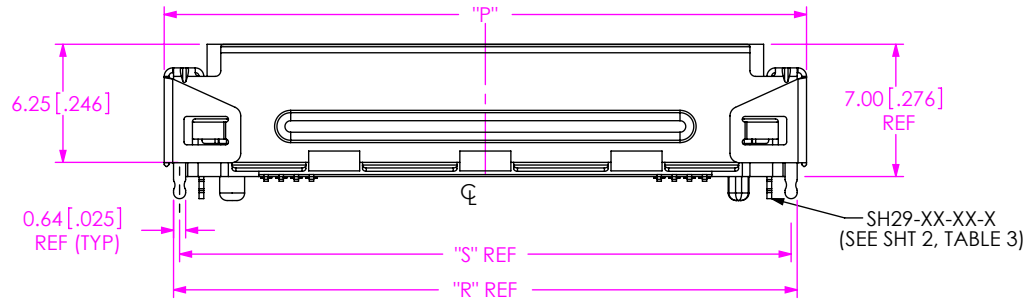
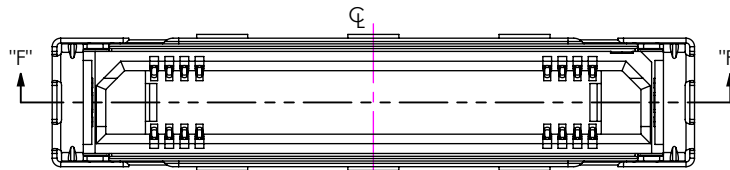

ERF8-XXX-07.0-DV-EGPS  
(SEE SHT 2, TABLE 3)

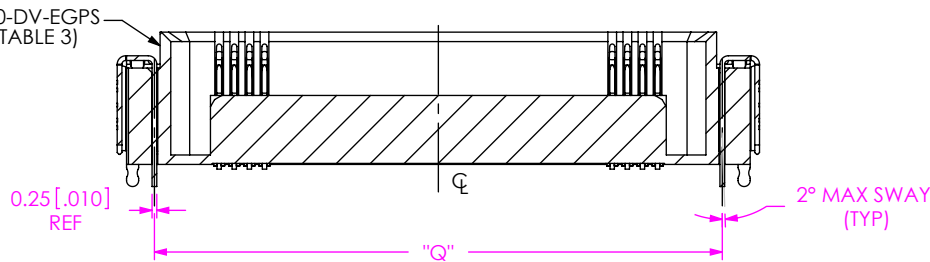

**SECTION "F"-"F"**  
**SCALE 2.5 : 1**

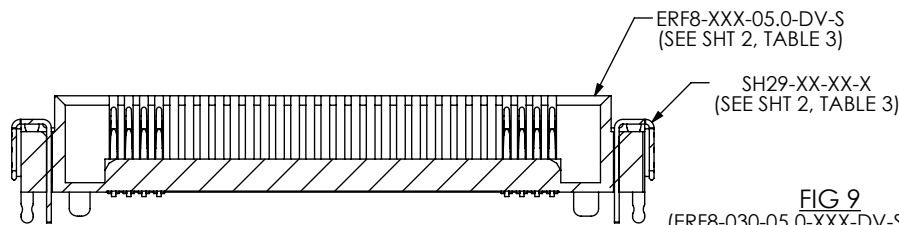
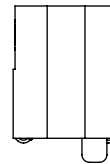
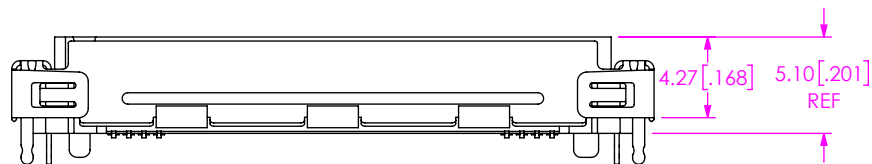
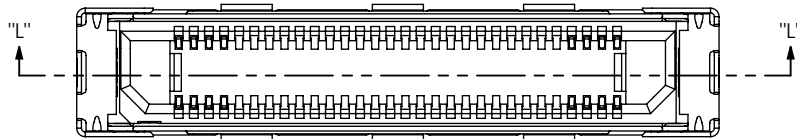

**SECTION "L"-"L"**  
**SCALE 2.5 : 1**

**FIG 9**  
(ERF8-030-05.0-XXX-DV-S SHOWN)  
(SAME AS FIG 6, EXCEPT AS SHOWN)  
(AVAILABLE ON -05.0 & -07.0 LEAD STYLE ONLY)

F:\DWG\MISC\MKTG\ERF8-XXX-XX.X-XXX-DV-XXXX-XX-MKT.SLDDRW

**TABLE 8**

No. OF POS.	"P"	"Q"+/-0.18 [.007]	"R"	"S"
-10	18.0 [.71]	14.00 [.551]	17.00 [.669]	16.36 [.644]
-20	26.0 [1.02]	22.00 [.866]	25.00 [.984]	24.36 [.959]
-25	30.0 [1.18]	26.00 [1.024]	29.00 [1.142]	28.36 [1.117]
-30	34.0 [1.34]	30.00 [1.181]	33.00 [1.299]	32.36 [1.274]

**PROPRIETARY NOTE**  
THIS DOCUMENT CONTAINS CONFIDENTIAL AND PROPRIETARY INFORMATION AND ALL DESIGN, MANUFACTURING, REPRODUCTION, USE, PATENT RIGHTS AND SALES RIGHTS ARE EXPRESSLY RESERVED BY SAMTEC, INC. THIS DOCUMENT SHALL NOT BE DISCLOSED, IN WHOLE OR PART, TO ANY UNAUTHORIZED PERSON OR ENTITY NOR REPRODUCED, TRANSFERRED OR INCORPORATED IN ANY OTHER PROJECT IN ANY MANNER WITHOUT THE EXPRESS WRITTEN CONSENT OF SAMTEC, INC.

DO NOT SCALE DRAWING  
SHEET SCALE: 3:1



520 PARK EAST BLVD, NEW ALBANY, IN 47150  
PHONE: 812-944-6733 FAX: 812-948-5047  
e-Mail info@SAMTEC.com code 55322

DESCRIPTION:  
0.8MM EDGE RATE SOCKET ASSEMBLY

DWG. NO.  
ERF8-XXX-XX.X-XXX-DV-XXXX-XX

BY: KNOWLDEN 9/26/2005 SHEET 4 OF 7

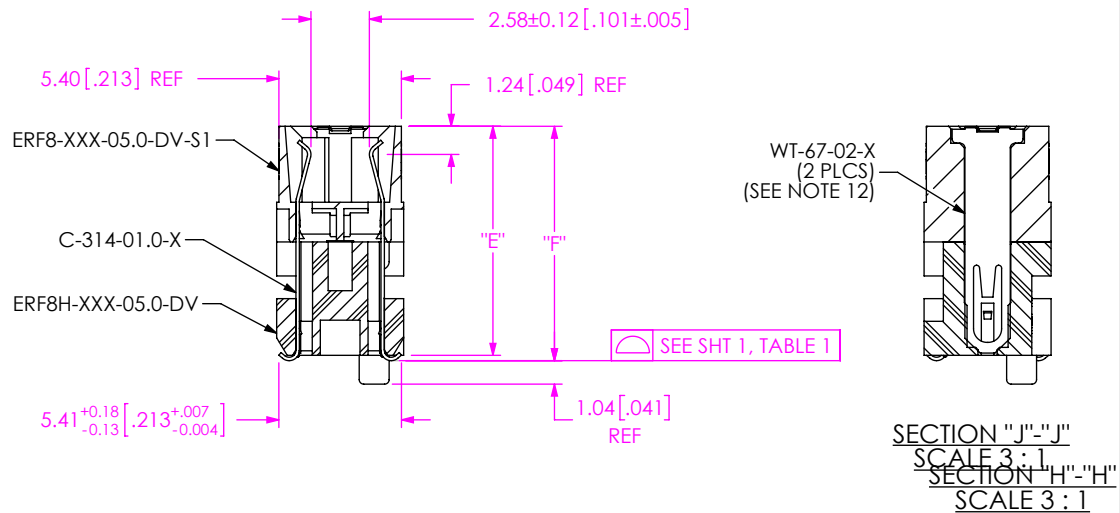
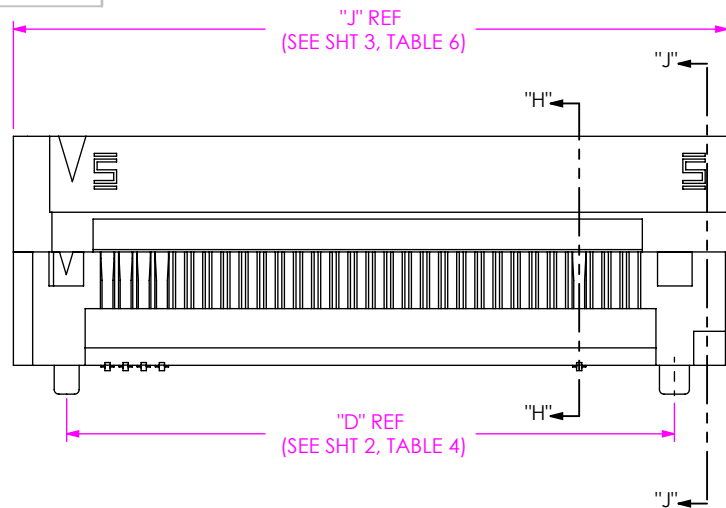

FIG 7  
(ERF8-030-10.0-XXX-DV SHOWN)  
(CENTER FEATURES REMOVED FOR CLARITY)  
(NOT TOOLED)

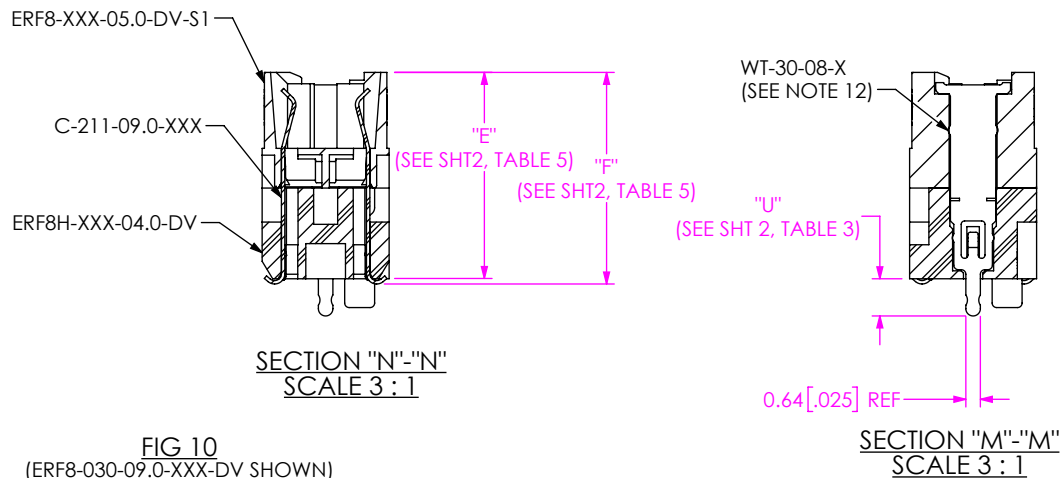
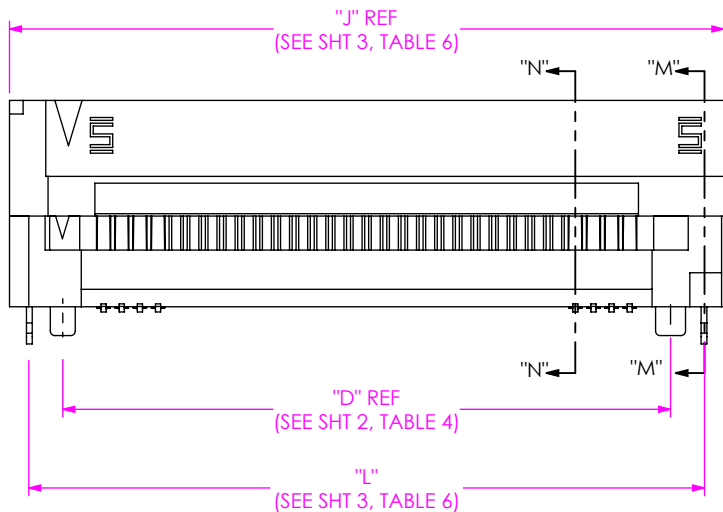

FIG 10  
(ERF8-030-09.0-XXX-DV SHOWN)  
(DIFFERENT AS SHOWN, OTHERWISE SAME AS FIG 7)

**PROPRIETARY NOTE**  
THIS DOCUMENT CONTAINS CONFIDENTIAL AND PROPRIETARY INFORMATION AND ALL DESIGN, MANUFACTURING, REPRODUCTION, USE, PATENT RIGHTS AND SALES RIGHTS ARE EXPRESSLY RESERVED BY SAMTEC, INC. THIS DOCUMENT SHALL NOT BE DISCLOSED, IN WHOLE OR PART, TO ANY UNAUTHORIZED PERSON OR ENTITY NOR REPRODUCED, TRANSFERRED OR INCORPORATED IN ANY OTHER PROJECT IN ANY MANNER WITHOUT THE EXPRESS WRITTEN CONSENT OF SAMTEC, INC.

DO NOT SCALE DRAWING

SHEET SCALE: 2:1

**samtec**

520 PARK EAST BLVD, NEW ALBANY, IN 47150  
PHONE: 812-944-6733 FAX: 812-948-5047  
e-Mail info@SAMTEC.com code 55322

DESCRIPTION:  
0.8MM EDGE RATE SOCKET ASSEMBLY

DWG. NO.  
ERF8-XXX-XX.X-XXX-DV-XXXX-XX

BY:KNOWL DEN 9/26/2005 SHEET 5 OF 7

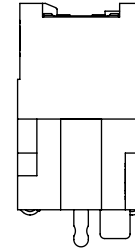
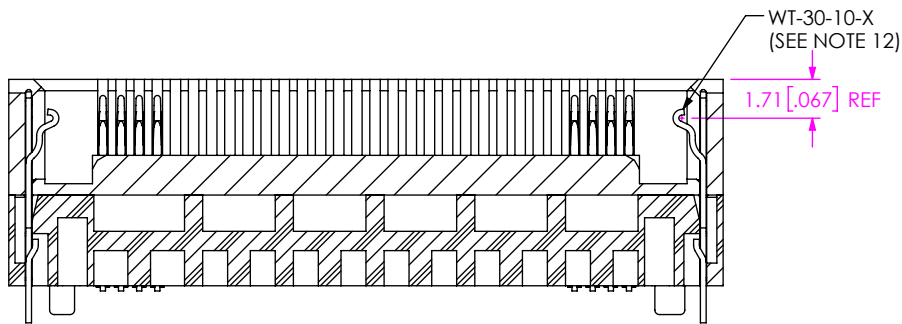
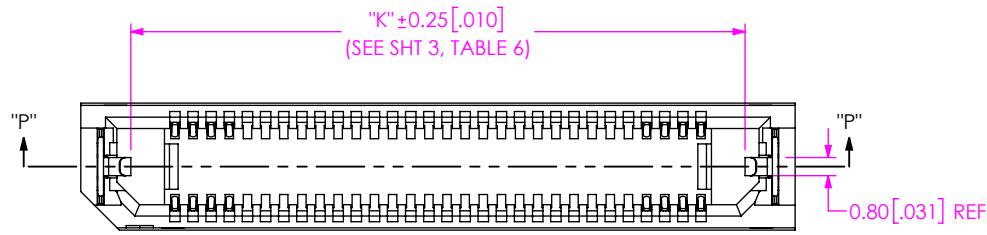

SECTION "P"-"P"  
SCALE 3 : 1

FIG 11  
(ERF8-030-09.0-XXX-DV-L SHOWN)  
(DIFFERENT AS SHOWN, OTHERWISE SAME AS FIG 10)

<p><b>PROPRIETARY NOTE</b></p> <p>THIS DOCUMENT CONTAINS CONFIDENTIAL AND PROPRIETARY INFORMATION AND ALL DESIGN, MANUFACTURING, REPRODUCTION, USE, PATENT RIGHTS AND SALES RIGHTS ARE EXPRESSLY RESERVED BY SAMTEC, INC. THIS DOCUMENT SHALL NOT BE DISCLOSED, IN WHOLE OR PART, TO ANY UNAUTHORIZED PERSON OR ENTITY NOR REPRODUCED, TRANSFERRED OR INCORPORATED IN ANY OTHER PROJECT IN ANY MANNER WITHOUT THE EXPRESS WRITTEN CONSENT OF SAMTEC, INC.</p>	<p><b>samtec</b></p> <p>520 PARK EAST BLVD, NEW ALBANY, IN 47150 PHONE: 812-944-6733 FAX: 812-948-5047 e-Mail info@SAMTEC.com code 55322</p>
<p>SHEET SCALE: 2:1</p>	<p>DESCRIPTION: 0.8MM EDGE RATE SOCKET ASSEMBLY</p>
	<p>DWG. NO. ERF8-XXX-XX.X-XXX-DV-XXXX-XX</p>
	<p>BY: KNOWLDEN 9/26/2005 SHEET 6 OF 7</p>

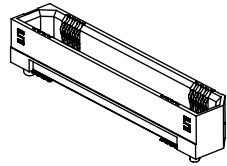

-05.0 SHOWN

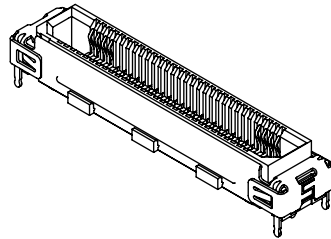

-05.0 WITH -S SHOWN

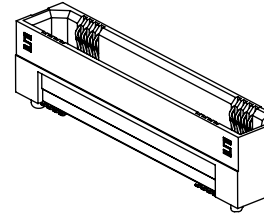

-07.0 SHOWN

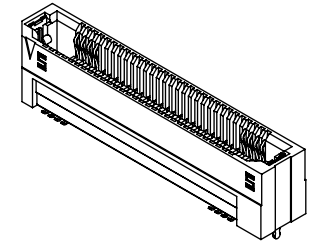

-07.0 WITH -L SHOWN

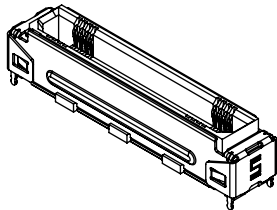

-07.0 WITH EGPS SHOWN

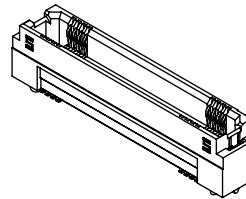

-07.0 WITH -EGP SHOWN

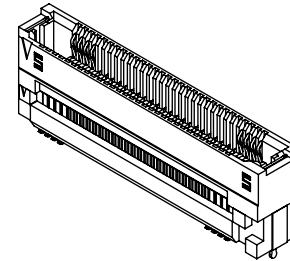

-09.0 OPTION

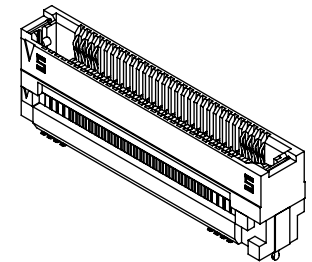

-09.0 WITH -L SHOWN

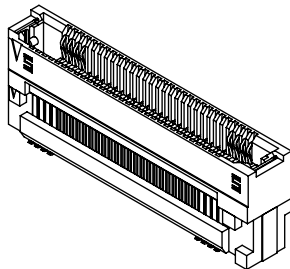

-10.0 SHOWN

**PROPRIETARY NOTE**  
 THIS DOCUMENT CONTAINS CONFIDENTIAL AND PROPRIETARY INFORMATION AND ALL DESIGN, MANUFACTURING, REPRODUCTION, USE, PATENT RIGHTS AND SALES RIGHTS ARE EXPRESSLY RESERVED BY SAMTEC, INC. THIS DOCUMENT SHALL NOT BE DISCLOSED, IN WHOLE OR PART, TO ANY UNAUTHORIZED PERSON OR ENTITY NOR REPRODUCED, TRANSFERRED OR INCORPORATED IN ANY OTHER PROJECT IN ANY MANNER WITHOUT THE EXPRESS WRITTEN CONSENT OF SAMTEC, INC.

DO NOT SCALE DRAWING

SHEET SCALE: 2:1



520 PARK EAST BLVD, NEW ALBANY, IN 47150  
 PHONE: 812-944-6733 FAX: 812-948-5047  
 e-Mail info@SAMTEC.com code 55322

DESCRIPTION:  
**0.8MM EDGE RATE SOCKET ASSEMBLY**

DWG. NO.  
**ERF8-XXX-XX.X-XXX-DV-XXXX-XX**

BY: KNOWLDEN 9/26/2005 SHEET 7 OF 7