

Long Range RF Modules

Features

- FM Narrow Band Crystal Stabilised
- Range up to 1,000 Metres
- 868MHz / 433MHz Versions
- 4 channel versions
 - 434.075MHz
 - 433.920MHz
 - 434.225MHz
 - 434.525MHz
- Miniature SIL Package
- Data Rates Up To 57Kbps
- En 300-220 Compliant
- Transmit Power +13dBm
- Receiver Sensitivity -121dBm
- RSSI Output

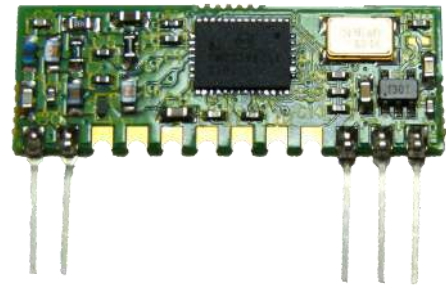

Applications

- Telemetry Systems
- Wireless Networking
- Domestic And Commercial Wireless Security Systems
- Panic Attack Facility
- General Purpose Remote Control

General Description

The T9/R9 series are miniature narrow band transmitter and receiver UHF radio modules, which enable the implementation of a simple telemetry link at data rates up to 57K6Kbits/s. These narrow band UHF radio modules provide a very high RF performance for general purpose applications.

The transmitter modules have a power output of up to +13dBm. When combined with a very high receiver sensitivity these modules obtain a very high performance of range and reliability within the 433MHz band.

Transmitter Connection Diagram

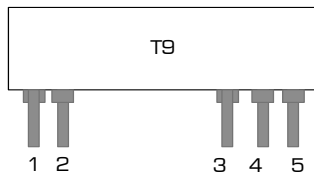

Pin Description:

RF GND (pin 1)

RF ground pin, internally connected to pin 4 (0v). This pin should ideally be connected to the nearest ground plane (e.g. coax braid, main PCB ground plane etc.).

RF OUT (pin 2)

50 Ohm RF antenna output. To achieve best results, the antenna impedance must match that of the module.

Vcc (pin 3)

+Ve supply pin. The module will generate RF when Vcc is present.

GND (pin 4)

Supply and data ground connection, connected to pin 1.

Data IN (pin 5)

Digital Data input. The drive circuitry should be supplied with the same supply voltage as the TX module.

Receiver Connection Diagram

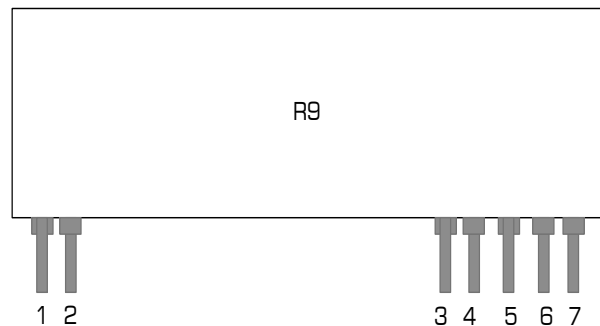

Pin Description:

RF IN (pin 1)

50 Ohm RF input from antenna, connect using shortest possible route. This input is isolated from the internal circuit using the air gap of the front end SAW RF filter.

RF GND (pin 2)

RF Ground connection, preferably connected to a solid ground plane.

RSSI / Carrier Detect (pin 3)

The Received Signal Strength Indicator provides a DC output voltage proportional to the RF input signal. The amplitude of the RSSI voltage increases with increasing RF signal strength. A simple transistor interface can yield a carrier detect logic output.

GND (pin 4)

Connect to power supply ground.

VCC (pin 5)

+Ve supply pin. Operation from a 5V supply able to source 10mA at less than 10mV p-p ripple.

AF (pin 6)

Audio frequency output (max 40microA source)

DATA OUT (pin 7)

CMOS compatible output. This may be used to drive external decoders. To reduce any noise on this output add a 56pF cap from this pin to GND.

Reducing Power to 10mW

If the T9 transmitter will be used with an efficient antenna in countries where only 10mW radiated power is allowed, then it is the responsibility of the user to ensure the radiated signal complies. A simple resistive network on the output of the module will attenuate the power down to this level. Resistor values will need to be set according to the power required.

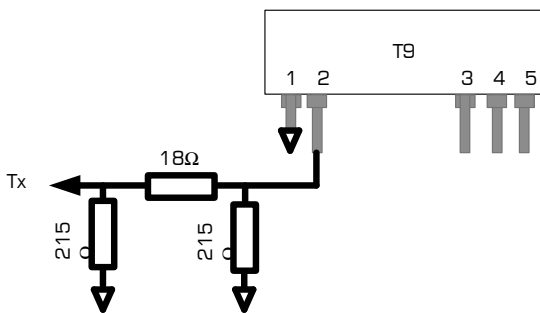

When laying out this network, keep all tracks as short as possible, especially ground paths and use 50 ohm track impedances when connecting to and from this network. This impedance can be realised on 1.6mm FR4 pcb by using a track width of 2.5mm.

RSSI Values

The R9 receiver RSSI outputs provide a DC output proportional to the level of RF signal received. The table below shows the typical RSSI value depending on the Signal strength.

RF Signal Strength (dBm)	R9 (V)
-130	1.03
-120	1.06
-110	1.16
-100	1.34
-90	1.59
-80	1.78
-70	1.81
-60	1.81
-50	2.17
-40	2.45
-30	2.52
-20	2.52

Mechanical Dimensions

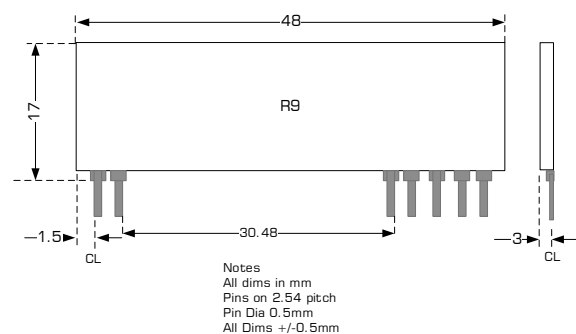
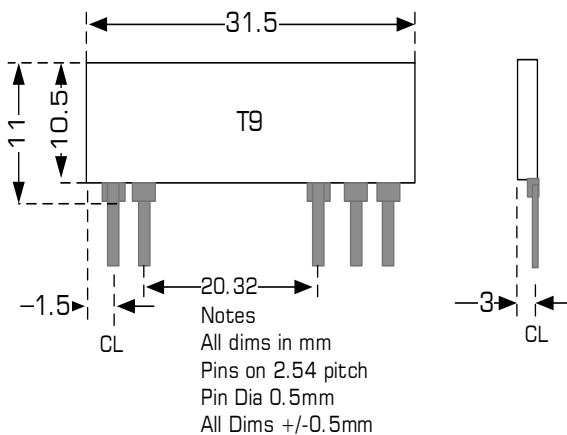

Antenna Design

The design and positioning of the antenna is as crucial as the module performance itself in achieving a good wireless system range. The following will assist the designer in maximising system performance.

The antenna should be kept as far away from sources of electrical interference as physically possible. If necessary, additional power line decoupling capacitors should be placed close to the module.

The antenna 'hot end' should be kept clear of any objects, especially any metal as this can severely restrict the efficiency of the antenna to receive power. Any earth planes restricting the radiation path to the antenna will also have the same effect.

Best range is achieved with either a straight piece of wire, rod or PCB track @ $\frac{1}{4}$ wavelength (16.4cm @ 433.92MHz). Further range may be achieved if the $\frac{1}{4}$ wave antenna is placed perpendicular in the middle of a solid earth plane measuring at least 16cm radius. In this case, the antenna should be connected to the module via some 50 ohm characteristic impedance coax.

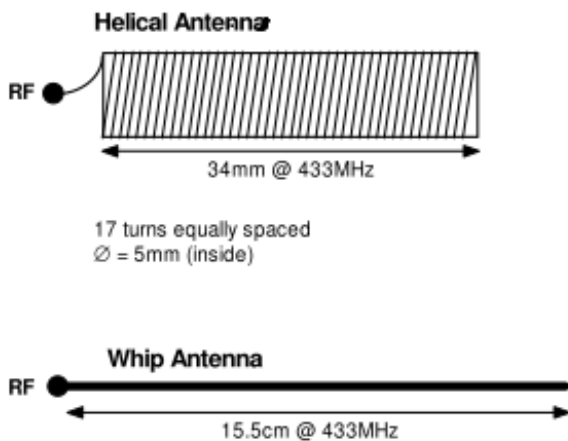

Application Circuits

The application circuits a remote control Schematic, for further Data please see DS600

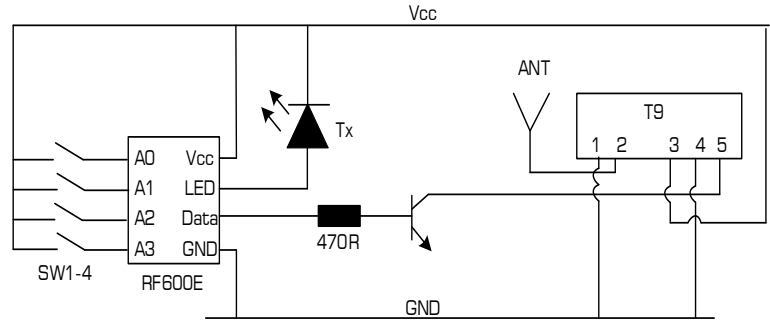

The transmitter application circuits generates a highly secure Keeloq protocol four switch transmitter encoder with LED indication or Transmission.

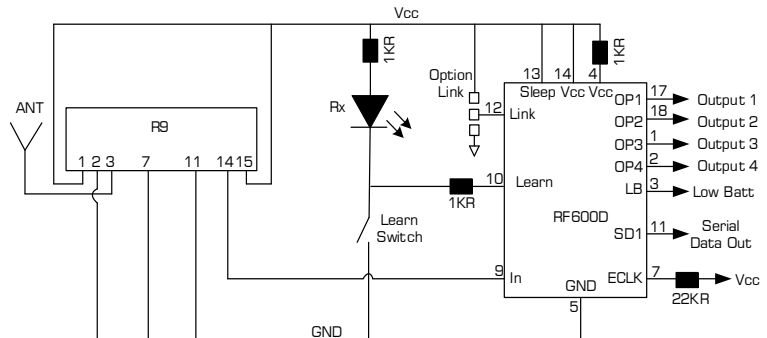

The Receiver application circuits generates a receiver decoder with four relay drive outputs and serial data output. It has easy Learn feature of the Keeloq transmitter and provides a Transmitter lower Battery indication.

Absolute Maximum Ratings: Transmitter (all voltage versions)

	T9 3V Version		T9 5V Version	
	Min.	Max.	Min.	Max.
Operating Temperature	-25°C	+55°C	-10°C	+55°C
Storage Temperature	-40°C	+100°C	-40°C	+100°C
Supply Voltage	-	3.6V	-	24V
Data Input	-	5.5V	-	10V

Electrical Characteristics: Transmitter

	T9 3V Version			T9 5V Version			Units	Pin	Note
	Min.	Typ.	Max.	Min.	Typ.	Max.			
DC Levels									
Supply (5V variants)				2.2	5.0	12.0	Volts	3	
Supply (3V variants)	2.2	3.0	3.6				Volts	3	
Current & RF Power									
Supply current		30			30		mA	3	1
RF output power			+13			+13	dBm	2	1
RF & Data (All Variants)									
2 nd harmonic		-60			-40		dBm		2
Harmonics @ > 1GHz		-60			-50		dBm		2
Initial frequency accuracy		+/-25			+/-25		KHz		
Frequency accuracy over full temp range			+/-30			±27	KHz		
Modulation bandwidth @ -3dB		50			50		KHz		3
Power up time to full RF		17			17		ms		
Data rate			20			20	kbps		
Data pulse width	50			50			ms		

Notes

1. Measured into a 50ohm impedance.
2. The limit for the European spec EN 300 220 is -36dBm
3. A +/-2.5KHz Deviation on the RF carrier is also available

Absolute Maximum Ratings: Receiver

	R9	
	Min.	Max.
Operating Temperature	-10°C	+55°C
Storage Temperature	-40°C	+100°C
Supply Voltage	-	24V
Data Input	-	5.5V

Electrical Characteristics: Transmitter

	R9			Units	Notes
	Min.	Typ.	Max.		
DC Levels					
Supply voltage	4.5	5	5.5	V	
Supply current	-	6	7	mA	
Supply ripple	-	-	10	mV _{P-P}	
Data output high		=>4.5		V	
Data output low		<=0.5		V	
RF					
RF sensitivity		-116		dBm	
IF Bandwidth		+/-27		KHz	
Initial frequency accuracy		+/-100		Hz	
Max R.F. input		20		dBm	
E.M.C.					
Spurious responses up to 1GHz		<60		dB	
LO leakage, conducted		<60		dBm	
LO leakage, radiated		<60		dBm	
Image rejection		63		dB	
DYNAMIC TIMING					
Power up to stable data <i>(With RF signal present)</i>		18	23	mS	1
Signal to stable data <i>(With PSU already on)</i>		2.5	5	mS	1
Power up to valid RSSI <i>(With RF signal Present)</i>		3	5	mS	1
Mark:space ratio		50		%	
Bit rate	100		20000	Bps	3

Notes

1. Timings are to be confirmed.
2. Note 1Hz = 2 bps

T9 R9 RF Modules



Part Numbering—Transmitters

Part No	Operating Frequency	Operating Voltage
T9-434-075	434.075MHz	5-10V
T9-434-075-3V	434.075MHz	3V
T9-433-920	434.920MHz	5-10V
T9-433-920-3V	434.920MHz	3V
T9-434-225	434.225MHz	5-10V
T9-434-225-3V	434.225MHz	3V
T9-434-525	434.225MHz	5-10V
T9-434-525-3V	434.525MHz	3V

Part Numbering—Receivers

Part No	Operating Frequency	Operating Voltage
R9-434-075	434.075MHz	5-10V
R9-433-920	434.920MHz	5-10V
R9-434-225	434.225MHz	5-10V
R9-434-525	434.525MHz	5-10V

Simplified Declaration of Conformity (RED)

BG - С настоящото RF Solutions Limited декларира, че този тип радиосъоръжение дефинирани в този документ е в съответствие с Директива 2014/53/ЕС. Цялостният текст на ЕС декларацията за съответствие може да се намери на следния интернет адрес: www.rfsolutions.co.uk

CS - Tímto RF Solutions Limited prohlašuje, že typ rádiového zařízení definované v tomto dokumentu je v souladu se směrnicí 2014/53/EU. Úplné znění EU prohlášení o shodě je k dispozici na této internetové adrese: www.rfsolutions.co.uk

DA - Hermed erklærer RF Solutions Limited, at radioudstyrstypen defineret i dette dokument er i overensstemmelse med direktiv 2014/53/EU. EU-overensstemmelseserklæringens fulde tekst kan findes på følgende internetadresse: www.rfsolutions.co.uk

DE - Hiermit erklärt RF Solutions Limited, dass der Funkanlagentyp in diesem Dokument definiert der Richtlinie 2014/53/EU entspricht. Der vollständige Text der EU-Konformitätserklärung ist unter der folgenden Internetadresse verfügbar: www.rfsolutions.co.uk

EL - Με την παρούσα ο/η RF Solutions Limited, δηλώνει ότι ο ραδιοεξοπλισμός ορίζεται σε αυτό το έγγραφο πληροί την οδηγία 2014/53/ΕΕ. Το πλήρες κείμενο της δήλωσης συμμόρφωσης ΕΕ διατίθεται στην ακόλουθη ιστοσελίδα στο διαδίκτυο: www.rfsolutions.co.uk

EN - Hereby, RF Solutions Limited declares that the radio equipment type defined within this document is in compliance with Directive 2014/53/EU. The full text of the EU declaration of conformity is available at the following internet address: www.rfsolutions.co.uk

ES - Por la presente, RF Solutions Limited declara que el tipo de equipo radioeléctrico definido dentro de este documento es conforme con la Directiva 2014/53/UE. El texto completo de la declaración UE de conformidad está disponible en la dirección Internet siguiente: www.rfsolutions.co.uk

ET - Käesolevaga deklareerib RF Solutions Limited, et käesolev raadioseadme tüüp määratletud selles dokumendis vastab direktiivi 2014/53/EL nõuetele. Eli vastavusdeklaratsiooni täielik tekst on kättesaadav järgmisel internetiaadressil: www.rfsolutions.co.uk

FI - RF Solutions Limited vakuuttaa, että radiolaitetyypin määrättyä selles dokumendis on direktiivin 2014/53/EU mukainen. EU-vaatimustenmukaisuusvakuutuksen täysimittainen teksti on saatavilla seuraavassa internetosoitteessa: www.rfsolutions.co.uk

FR - Le soussigné, RF Solutions Limited, déclare que l'équipement radioélectrique du type défini dans ce document est conforme à la directive 2014/53/UE. Le texte complet de la déclaration UE de conformité est disponible à l'adresse internet suivante: www.rfsolutions.co.uk

HR - RF Solutions Limited ovime izjavljuje da je radijska oprema tipa definirani u ovom dokumentu u skladu s Direktivom 2014/53/EU. Cjeloviti tekst EU izjave o sukladnosti dostupan je na sljedećoj internetskoj adresi: www.rfsolutions.co.uk

HU - RF Solutions Limited igazolja, hogy a dokumentumban meghatározottak szerint típusú rádióberendezés megfelel a 2014/53/EU irányelvnek. Az EU-megfelelőségi nyilatkozat teljes szövege elérhető a következő internetes címen: www.rfsolutions.co.uk

IT - Il fabbricante, RF Solutions Limited, dichiara che il tipo di apparecchiatura radio definito all'interno di questo documento è conforme alla direttiva 2014/53/UE. Il testo completo della dichiarazione di conformità UE è disponibile al seguente indirizzo Internet: www.rfsolutions.co.uk

LT - Aš, RF Solutions Limited, patvirtinu, kad radijo įrenginių tipas apibrėžta šiame dokumente atitinka Direktyvą 2014/53/ES. Visas ES atitikties deklaracijos tekstas prieinamas šiuo interneto adresu: www.rfsolutions.co.uk

LV - Ar šo RF Solutions Limited deklarē, ka radioiekārta kas definēts šajā dokumentā atbilst Direktīvai 2014/53/ES. Pilns ES atbilstības deklarācijas teksts ir pieejams šādā interneta vietnē: www.rfsolutions.co.uk

MT - B'dan, RF Solutions Limited, niddkjara li dan it-tip ta' tagħmir tar-radju definit f'dan id-dokument huwa konformi mad-Direttiva 2014/53/UE. It-test kollu tad-dikjarazzjoni ta' konformità tal-UE huwa disponibbli f'dan l-indirizz tal-Internet li ġej: www.rfsolutions.co.uk

NL - Hierbij verklaar ik, RF Solutions Limited, dat het type radioapparaatuur gedefinieerd in dit document conform is met Richtlijn 2014/53/EU. De volledige tekst van de EU-conformiteitsverklaring kan worden geraadpleegd op het volgende internetadres: www.rfsolutions.co.uk

PL - RF Solutions Limited niniejszym oświadczam, że typ urządzenia radiowego zdefiniowane w tym dokumencie jest zgodny z dyrektywą 2014/53/UE. Pełny tekst deklaracji zgodności UE jest dostępny pod następującym adresem internetowym: www.rfsolutions.co.uk

PT - O(a) abaixo assinado(a) RF Solutions Limited declara que o presente tipo de equipamento de rádio definido neste documento está em conformidade com a Diretiva 2014/53/UE. O texto integral da declaração de conformidade está disponível no seguinte endereço de Internet: www.rfsolutions.co.uk

RO - Prin prezenta, RF Solutions Limited declară că tipul de echipamente radio definit în acest document este în conformitate cu Directiva 2014/53/UE. Textul integral al declarației UE de conformitate este disponibil la următoarea adresă internet: www.rfsolutions.co.uk

SK - RF Solutions Limited týmto vyhlasuje, že rádiové zariadenie typu definované v tomto dokumente je v súlade so smernicou 2014/53/EÚ. Úplné EÚ vyhlásenie o zhode je k dispozícii na tejto internetovej adrese: www.rfsolutions.co.uk

SL - RF Solutions Limited potrjuje, da je tip radijske opreme opredeljeno v tem dokumentu skladen z Direktivo 2014/53/EU. Celotno besedilo izjave EU o skladnosti je na voljo na naslednjem spletnem naslovu: www.rfsolutions.co.uk

SV - Härmed försäkrar RF Solutions Limited att denna typ av radioutrustning definieras i detta dokument överensstämmer med direktiv 2014/53/EU. Den fullständiga texten till EU-försäkran om överensstämmelse finns på följande webbadress: www.rfsolutions.co.uk

RF Solutions Ltd. Recycling Notice

Meets the following EC Directives:

DO NOT

Discard with normal waste, please recycle.

ROHS Directive 2011/65/EU and amendment

2015/863/EU

Specifies certain limits for hazardous substances.

WEEE Directive 2012/19/EU

Waste electrical & electronic equipment. This product must be disposed of through a licensed WEEE collection point. RF Solutions Ltd., fulfills its WEEE obligations by membership of an approved compliance scheme.

Environment Agency producer registration number: **WEE/JB0104WV**.



Waste Batteries and Accumulators

Directive 2006/66/EC

Where batteries are fitted, before recycling the product, the batteries must be removed and disposed of at a licensed collection point.

Rf Solutions battery producer number:

BPRN00060.

Disclaimer:

Whilst the information in this document is believed to be correct at the time of issue, RF Solutions Ltd does not accept any liability whatsoever for its accuracy, adequacy or completeness. No express or implied warranty or representation is given relating to the information contained in this document. RF Solutions Ltd reserves the right to make changes and improvements to the product(s) described herein without notice.

Buyers and other users should determine for themselves the suitability of any such information or products for their own particular requirements or specification(s). RF Solutions Ltd shall not be liable for any loss or damage caused as a result of user's own determination of how to deploy or use RF Solutions Ltd's products. Use of RF Solutions Ltd products or components in life support and/or safety applications is not authorised except with express written approval. No licences are created, implicitly or otherwise, under any of RF Solutions Ltd's intellectual property rights. Liability for loss or damage resulting or caused by reliance on the information contained herein or from the use of the product (including liability resulting from negligence or where RF Solutions Ltd was aware of the possibility of such loss or damage arising) is excluded. This will not operate to limit or restrict RF Solutions Ltd's liability for death or personal injury resulting from its negligence.