

Verpackt im Gurt in Anlehnung an DIN IEC 60286-3
tape on reel packaging according to DIN IEC 60286-3
 Verpackungseinheit: 240 Stück
packaging unit: 240 pcs

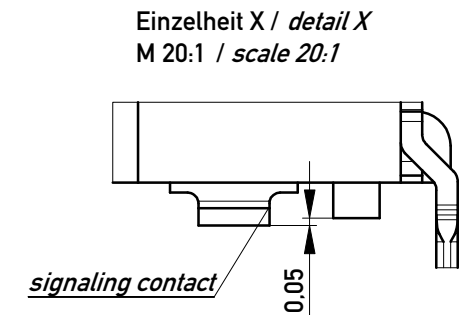

Abspulrichtung - *Reel off Direction* →

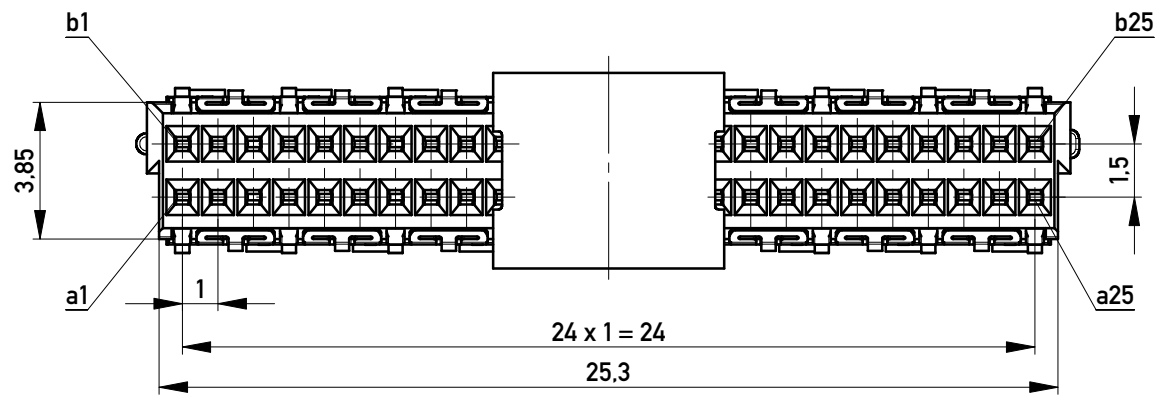
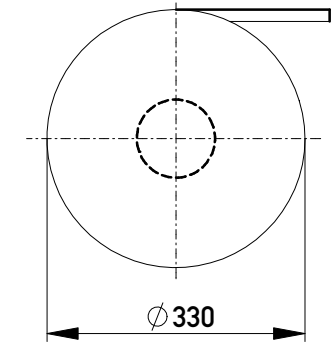
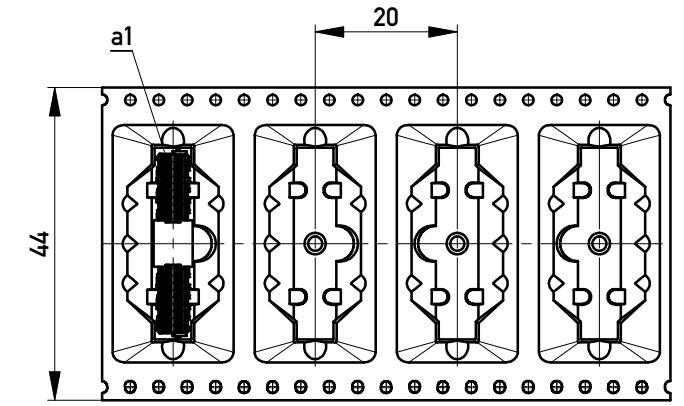

Leiterplatten-Layout Vorschlag / PCB-Layout Proposal

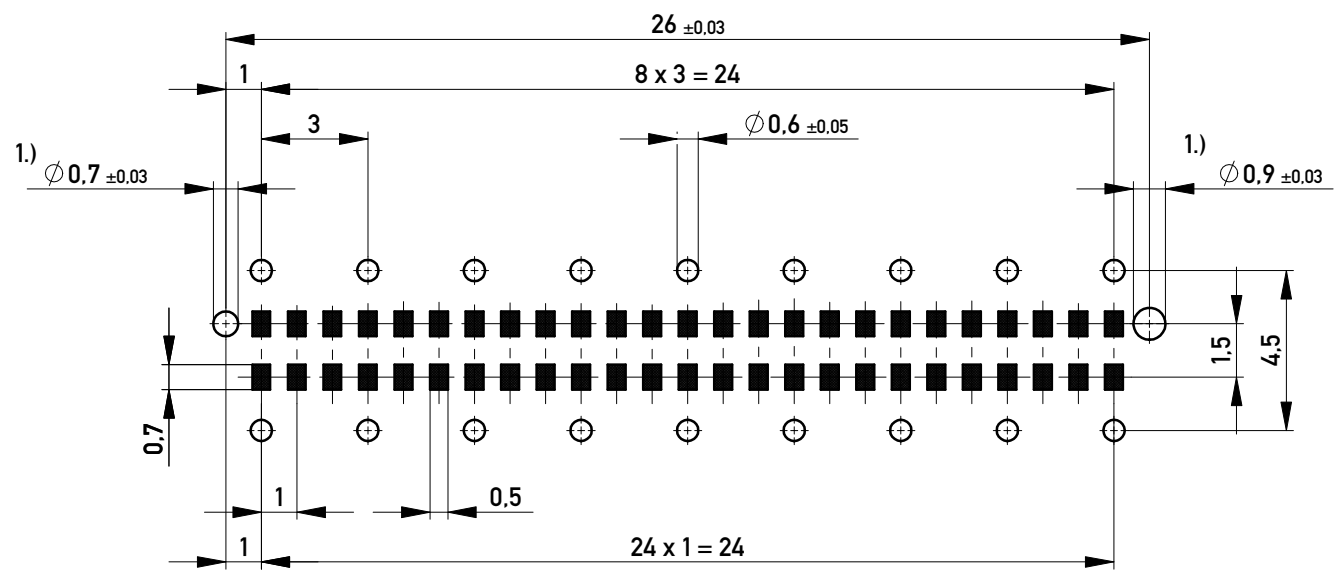

1.) Durchmesser des Bohrers / *Drill tool*

Anforderungsstufe 1
Performance Level 1

Kontaktbereich vergoldet
Mating Area gold plating

Anschlussbereich verzinkt 4-6µm
Terminal Area 4-6µm tin plating

Koplanarität der Anschlüsse ≤ 0,1mm
Coplanarity Area of Termination ≤ 0,1mm

Information: All rights reserved. Only for Information. To ensure that this is the latest version of this drawing, please contact one of the ERNI companies before using.	Tolerances All Dimensions in mm	Scale	5:1
		Designation Federleiste 8mm THR, 50 polig <i>Female 8mm THR, 50 contacts</i>	
Subject to modification without prior notice. Drawing will not be updated.		www.ERNI.com	
		224515	
g	20.10.2017	Class	MSPEED
Index	Date		I A3

Copyright by ERNI GmbH
 Proprietary notice pursuant to ISO 16016 to be observed.