

1. Wiring Diagram.

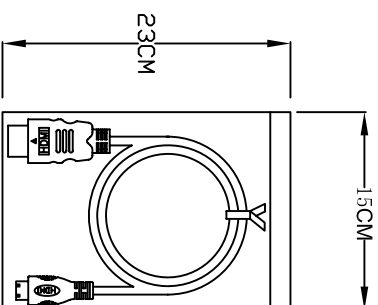
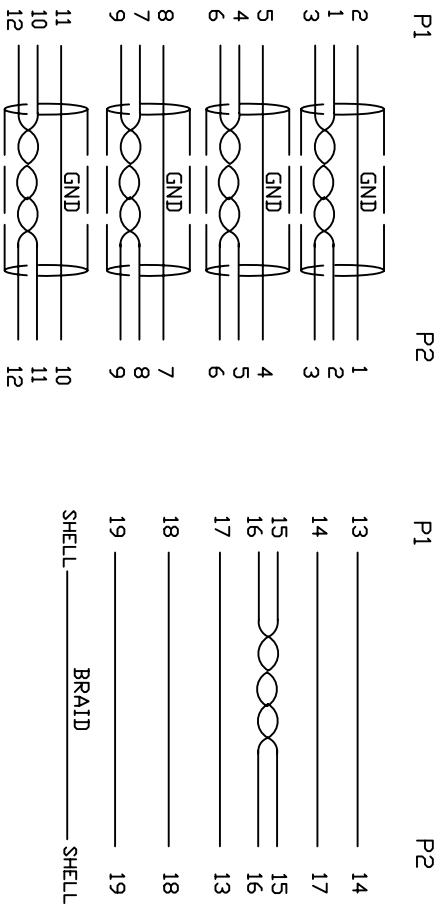

2. Cable test condition :

Open / Short : 100%

Insulation resistance : 5M ohms

Contact resistance : 2 ohm

Hipot : DC 300V / 1 sec

3. Each pcs with PE polybag.

7	COOPER	W/25MM*L45MM	1	
6	COOPER	W/20MM*L35MM	1	
5	PVC	4SP PVC BLACK OVERMOLD	25g	
4	PE	LLDPE 500026 6201 INSIDE MOLDING	16g	
3	CONN	HDMI C TYPE MALE PIN G/F ,SHELL PLATED NICKEL, INSULATION BLACK	1	P2
2	CONN	HDMI A TYPE MALE PIN G/F ,SHELL PLATED NICKEL, INSULATION BLACK	1	P1
1	CABLE	UL20276 (30AWG (7/0. ITS) *P+EA+AL/MY) *4+30AWG (7/0. ITS) *5C +AEM(16/6/0.12AM) OD6.0 BLACK	1	1000mm
NO.	PART NO.	DESCRIPTION	QTY	UNIT/REF
BILL OF MATERIAL				

A	INITIAL RELEASE	2015/10/10
REVISION#	DESCRIPTION	DATE
Cnc Tech, LLC		
DRAWN	EDWIN LAI	DATE
CHECKED	W. In. C	10/10/15
APPROVAL		
DWN NO.	742-10010-00100	REV
CUSTOMER P/N:		
CUSTOMER:		
SHEET	1 OF 1	