

## FS1023

Liquid Flow Sensor Module

The FS1023 liquid flow sensor module measures the flow rate using the thermo-transfer (calorimetric) principle.

The FS1023 offers key advantages over resistor-based flow solutions. The sensor utilizes thermopile sensing, which provides an excellent signal-to-noise ratio. The sensor comprises a “solid” thermal isolation technology with protective coating.

The non-linear flow output curve allows for sensitivity from low to full-scale flow rates. The FS1023 provides analog output.

### Module Picture



### Features

- Liquid flow: 0 to 3 liters/min (with water)
- Robust “solid” isolation technology
- Resistant to vibration and pressure shock
- Minimal flow resistance
- Analog voltage output
- Supply voltage: 5V

### Applications

- Water dispensers
- Liquid metering or switch
- Process controls and monitoring



## Contents

<b>1. Pin Information</b>	<b>3</b>
1.1 Pin Assignments	3
1.2 Pin Descriptions	3
<b>2. Specifications</b>	<b>4</b>
2.1 Absolute Maximum Ratings	4
2.2 Recommended Operating Conditions	4
2.3 Electrical Characteristics	4
<b>3. Typical Flow Graphs</b>	<b>5</b>
3.1 Heater Enable	5
3.2 Electrical Connector	5
3.3 Module Material	6
3.4 Tubing Guidance	6
<b>4. Package Outline Drawings</b>	<b>6</b>
<b>5. Ordering Information</b>	<b>6</b>
<b>6. Revision History</b>	<b>6</b>

# 1. Pin Information

## 1.1 Pin Assignments

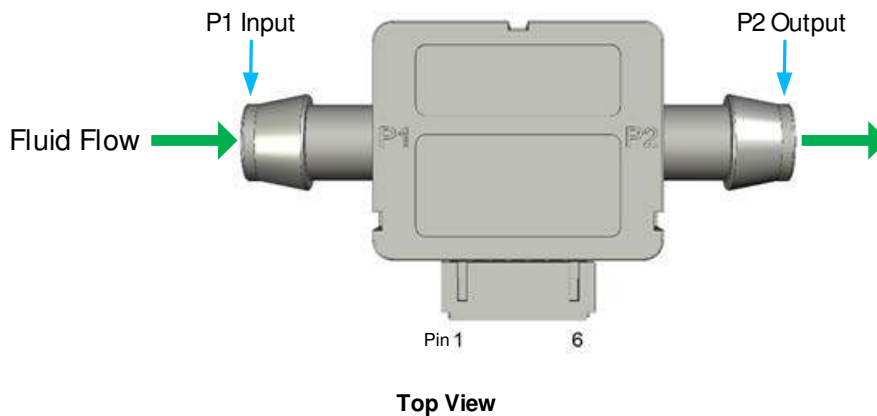

## 1.2 Pin Descriptions

Pin Number	Pad Name	Type	Description
1	VDD	Input	Supply voltage.
2	GND	Input	Ground.
3	OUTPUT	Output	Flow analog output.
4	NC	-	Do not connect.
5	HE	Input	Heater enable, connect to +5V.
6	TEMP	Output	Thermistor analog output.

1. "NC" stands for not connected / no connection required / not bonded.

## 2. Specifications

### 2.1 Absolute Maximum Ratings

**CAUTION:** Do not operate at or near the maximum ratings listed for extended periods of time. Exposure to such conditions can adversely impact product reliability and result in failures not covered by warranty.

Symbol	Parameter	Conditions	Minimum	Maximum	Unit
$V_{IN}$	Supply Voltage	-	5	5.5	V
$T_{STOR}$	Storage Temperature	-	0	85	°C

### 2.2 Recommended Operating Conditions

Symbol	Parameter	Minimum	Typical	Maximum	Unit
$V_{IN}$	Supply Voltage	-	5	5.5	V
$T_{AMB}$	Ambient Operating Temperature (in air)	0	-	70	°C
$P_{STAT}$	Static Pressure	-	-	30	PSI

### 2.3 Electrical Characteristics

Symbol	Parameter	Conditions	Minimum	Typical	Maximum	Unit
$I_{VIN}$	Current Consumption	-	-	18	20	mA
$F_{LQ}$	Liquid Flow Range	Tested with water, room temperature.	0	-	3	Liter/min
$V_{AOUT}$	Analog Voltage Output	Non-linear curve.	0	-	5	V
$V_{NULL}$	Flow Null Voltage	No flow.	-	0.005	-	V
$\tau_H$	Flow Response Time <sup>[1]</sup>	-	-	5	-	msec
$V_{TEMP}$	Temperature Output	At 5°C.	-	4.25	-	V
		At 80°C.	-	1.0	-	

- The flow response time includes a 10% to 90% rise time for the flow sensor to electrically respond to any flow change. Measurements may be affected by the pneumatic interface.

### 3. Typical Flow Graphs

Figure 1 show the typical analog output versus flow (with water). From a flow rate of 0.5 to 3 SLPM, the voltage output can be correlated by the following approximation:

$$\text{Flow rate (liters/min)} = 0.017 * (V_{out})^2 + 0.62 * (V_{out}) - 0.47$$

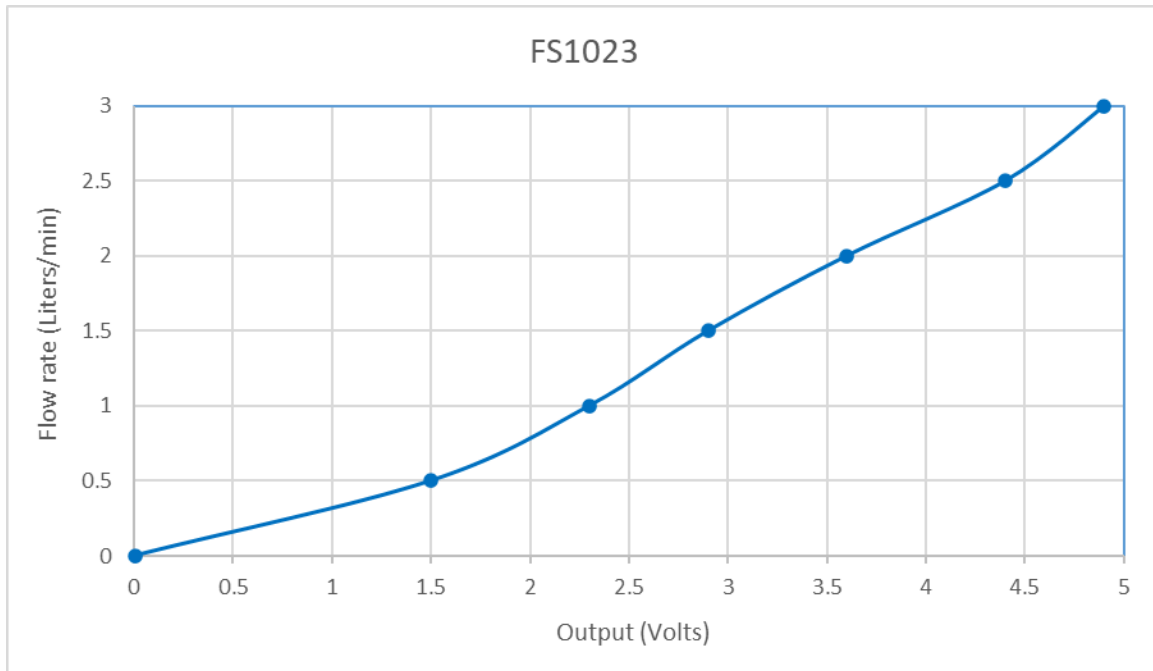

Figure 1. Analog Output Curve (in Water, Room Temperature)

#### 3.1 Heater Enable

The FS1023 allows power savings through the operation of the Heater Enable (HE) pin. The flow sensor element includes a micro-heater. The HE pin powers the micro-heater. When a measurement is taken, the HE pin must be powered on and connected to +5VDC. To conserve power, the HE pin can be pulsed on when taking measurements or grounded (turned off) when no measurements are required. Alternatively, the HE pin can be constantly powered on.

#### 3.2 Electrical Connector

A 6-position receptacle (not provided) is required to mate to the board crimp style connector. A part number example is PHR-6 (JST).

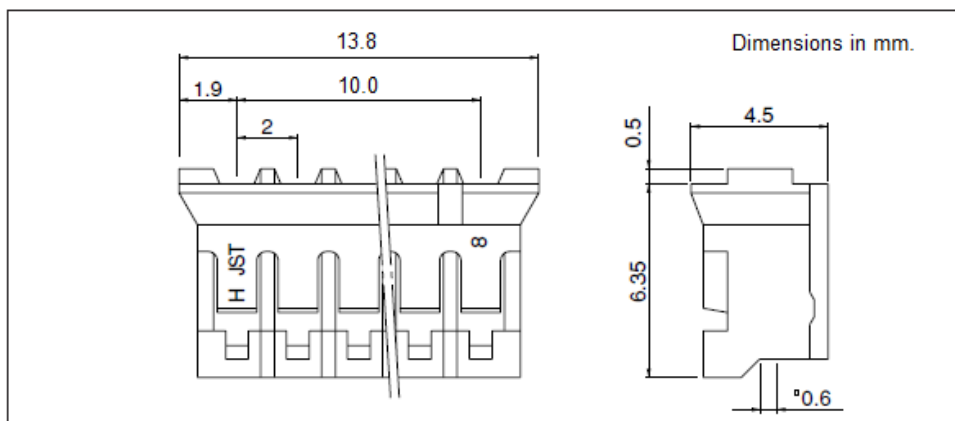

Figure 2. Receptacle Drawing

### 3.3 Module Material

The wetted contact surface of the FS1023 consists of the following:

- Housing – Polyphenylene Ether (PPE) + Polystyrene (PS) blend resin
- Flow Sensor – Silicon-carbide thin film
- Epoxy
- Gasket – Silicone
- Substrate – Gold plating

### 3.4 Tubing Guidance

The FS1023 module has barb tube endings. Soft tubing with a nominal 3/8-inch (9.5mm) internal diameter is recommended for use. A clamp may be necessary to secure the tubing over the barb.

## 4. Package Outline Drawings

The package outline drawings are located at the end of this document and are accessible from the Renesas website. The package information is the most current data available and is subject to change without revision of this document.

## 5. Ordering Information

Part Number	Package Description	Carrier Type	Temperature Range
FS1023	0 to 3 liter/min liquid flow sensor module with analog voltage output (see <a href="#">MOD1</a> )	Tray	0° to +70°C

## 6. Revision History

Revision	Date	Description
1.01	Sep 1, 2022	Updated reference output with water.
1.00	Jul 2, 2021	Initial release.

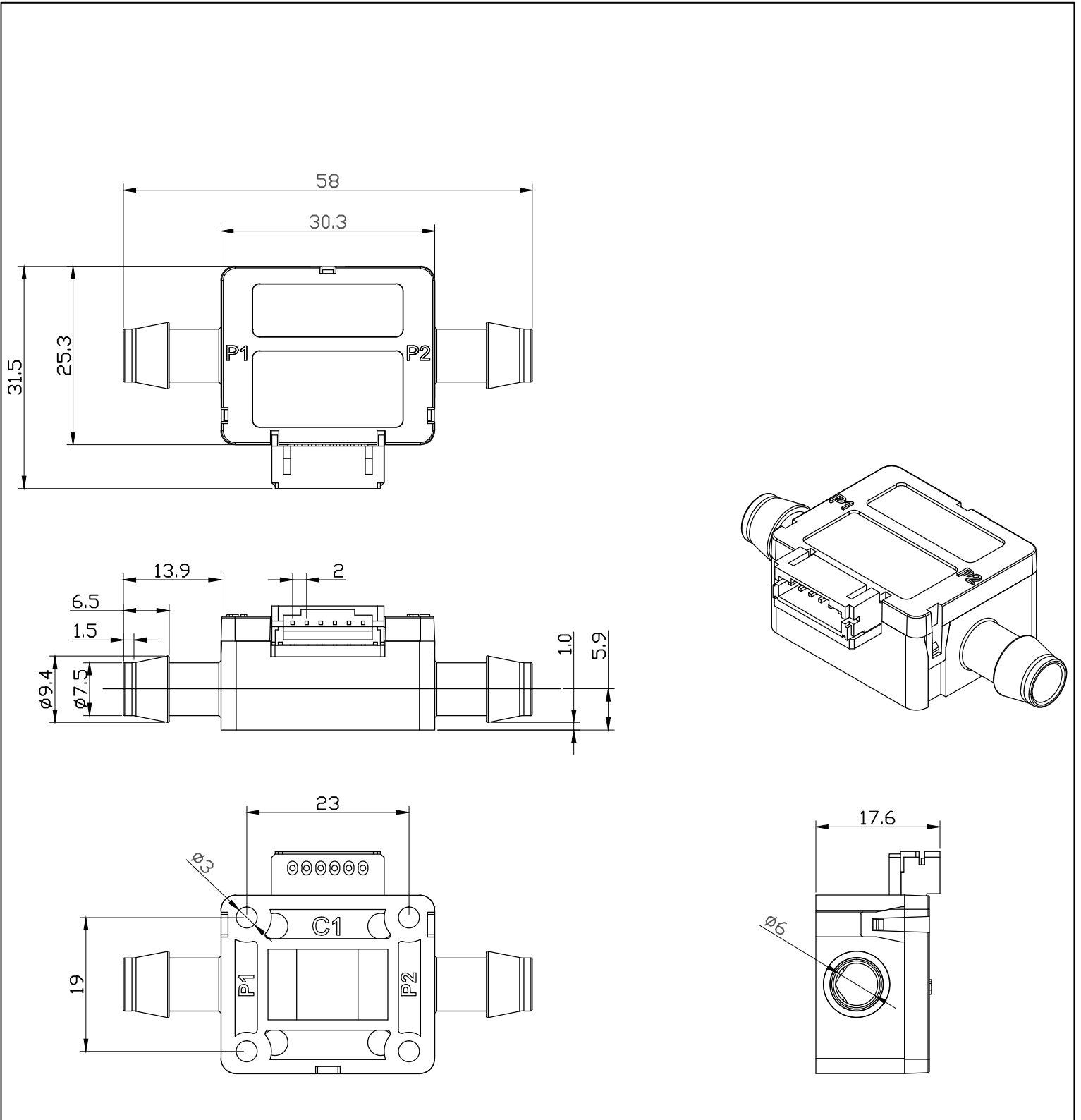

Package Revision History		
Date Created	Rev No.	Description
Nov 28, 2017	Rev 00	Initial Release

## IMPORTANT NOTICE AND DISCLAIMER

RENESAS ELECTRONICS CORPORATION AND ITS SUBSIDIARIES (“RENESAS”) PROVIDES TECHNICAL SPECIFICATIONS AND RELIABILITY DATA (INCLUDING DATASHEETS), DESIGN RESOURCES (INCLUDING REFERENCE DESIGNS), APPLICATION OR OTHER DESIGN ADVICE, WEB TOOLS, SAFETY INFORMATION, AND OTHER RESOURCES “AS IS” AND WITH ALL FAULTS, AND DISCLAIMS ALL WARRANTIES, EXPRESS OR IMPLIED, INCLUDING, WITHOUT LIMITATION, ANY IMPLIED WARRANTIES OF MERCHANTABILITY, FITNESS FOR A PARTICULAR PURPOSE, OR NON-INFRINGEMENT OF THIRD PARTY INTELLECTUAL PROPERTY RIGHTS.

These resources are intended for developers skilled in the art designing with Renesas products. You are solely responsible for (1) selecting the appropriate products for your application, (2) designing, validating, and testing your application, and (3) ensuring your application meets applicable standards, and any other safety, security, or other requirements. These resources are subject to change without notice. Renesas grants you permission to use these resources only for development of an application that uses Renesas products. Other reproduction or use of these resources is strictly prohibited. No license is granted to any other Renesas intellectual property or to any third party intellectual property. Renesas disclaims responsibility for, and you will fully indemnify Renesas and its representatives against, any claims, damages, costs, losses, or liabilities arising out of your use of these resources. Renesas' products are provided only subject to Renesas' Terms and Conditions of Sale or other applicable terms agreed to in writing. No use of any Renesas resources expands or otherwise alters any applicable warranties or warranty disclaimers for these products.

(Disclaimer Rev.1.0 Mar 2020)

### Corporate Headquarters

TOYOSU FORESIA, 3-2-24 Toyosu,  
Koto-ku, Tokyo 135-0061, Japan  
[www.renesas.com](http://www.renesas.com)

### Contact Information

For further information on a product, technology, the most up-to-date version of a document, or your nearest sales office, please visit:  
[www.renesas.com/contact/](http://www.renesas.com/contact/)

### Trademarks

Renesas and the Renesas logo are trademarks of Renesas Electronics Corporation. All trademarks and registered trademarks are the property of their respective owners.