

THIS DOCUMENT IS THE PROPERTY OF  
KEYSTONE ELECTRONICS CORP. AND  
SHALL NOT BE REPRODUCED, DISTRIBUTED  
OR USED AS A BASIS FOR MANUFACTURE  
WITHOUT PRIOR WRITTEN PERMISSION  
FROM KEYSTONE ELECTRONICS CORP.

ACTUAL SIZE

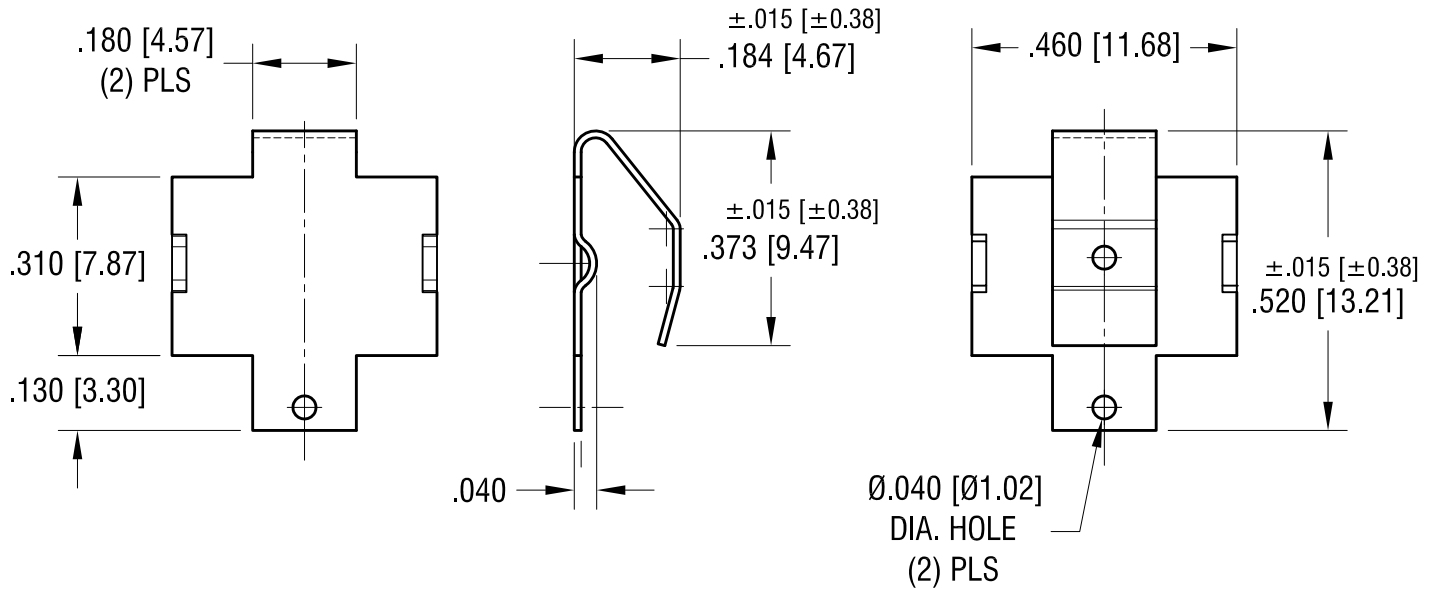

**KEYSTONE ELECTRONICS CORP.**

www.keyelco.com • NEW HYDE PARK NY 11040 • Tel (516)328-7500

PART NAME

SINGLE 'AA' BATTERY CLIP

MATERIAL

.012 [0.30] TH'K SPRING STEEL

FINISH

NICKEL PLATE

DRN BY

NT

DATE

12.20.21

APP'D

RH

SCALE

3X

TOLERANCES

INCH [MM]

DECIMAL  $\pm .010 [\pm 0.25]$

ANGULAR  $\pm 1^\circ$   
UNLESS OTHERWISE SPECIFIED

CODE

C

DWG NO.

5233

DATE

DESCRIPTION

REV.