



The Future of Analog IC Technology®

# MP4056

## TRIAC Dimmable, Non-isolated Offline LED Controller with Active PFC

### DESCRIPTION

The MP4056 is a non-isolated, TRIAC-dimmable, offline LED controller with active PFC. It outputs an accurate LED current for a non-isolated lighting application with a single-stage converter.

The MP4056 implements power-factor correction and works in boundary-conduction mode to reduce MOSFET switching losses.

The adaptive dimmer type detection and phase-cut-based dimming control achieves good dimmer compatibility and deep dimming range.

The MP4056 has an integrated charging circuit at the supply pin for fast start-up without a perceptible delay.

With the unique control of DIM, the MP4056 supports color temperature and brightness control for warm sunset dimming application.

The MP4056 has multiple protections that greatly enhance system reliability and safety, including output over-voltage protection, output short-circuit protection, over-current protection, programmable thermal fold-back (MSOP10/SOIC14), ZCD pin short circuit protection, supply-pin under-voltage lockout, and over-temperature protection.

All fault protections feature auto-restart.

The MP4056 is available in SOIC-8/MSOP-10/SOIC-14 package.

### FEATURES

- Adaptive Dimmer Type Detection and Phase-Cut-Based Dimming Control
- Good Dimmer Compatibility and Deep Dimming Range
- PWM Input Analog Dimming
- Fast Start-Up without Perceptible Delay
- Programmable Current Fold-back to Prolong the LED lifetime (NTC)
- Color Temperature and Brightness Control for Warm Sunset Dimming application
- Accurate Line & Load Regulation
- High Power Factor
- Operates in Boundary Conduction Mode
- Cycle-by-Cycle Current Limit
- Over-current Protection
- Output Over-Voltage Protection
- Output Short-Circuit Protection
- ZCD Pin Short-Circuit Protection
- Over-Temperature Protection
- Available in SOIC-8/MSOP-10/SOIC-14 Package

### APPLICATIONS

- Solid-State Lighting up to 50W
- Industrial and Commercial Lighting
- Residential Lighting

All MPS parts are lead-free, halogen free, and adhere to the RoHS directive. For MPS green status, please visit MPS website under Quality Assurance.

"MPS" and "The Future of Analog IC Technology" are Registered Trademarks of Monolithic Power Systems, Inc.

**TYPICAL APPLICATION**

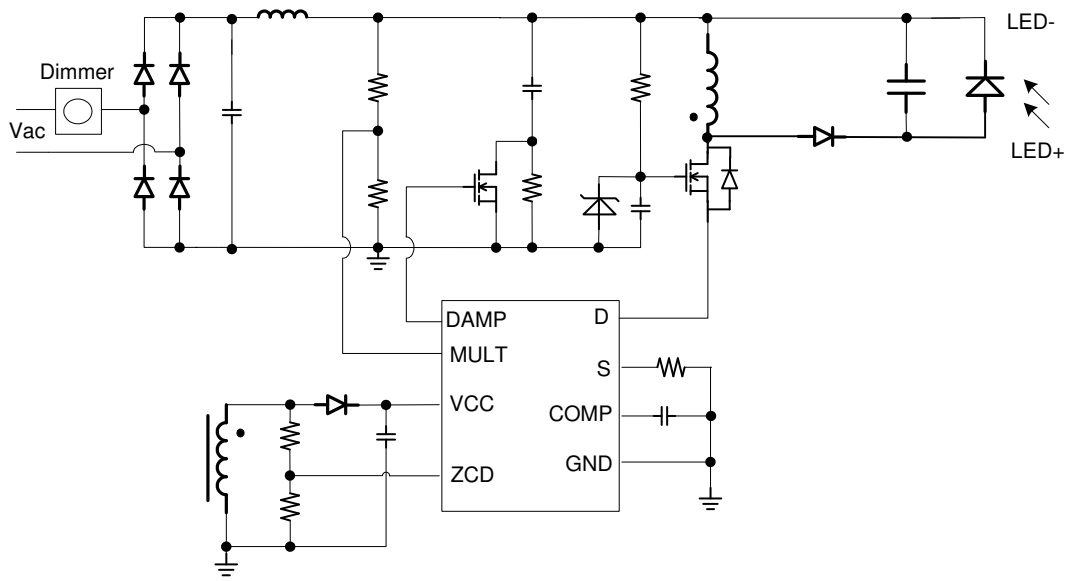

**SOIC8**

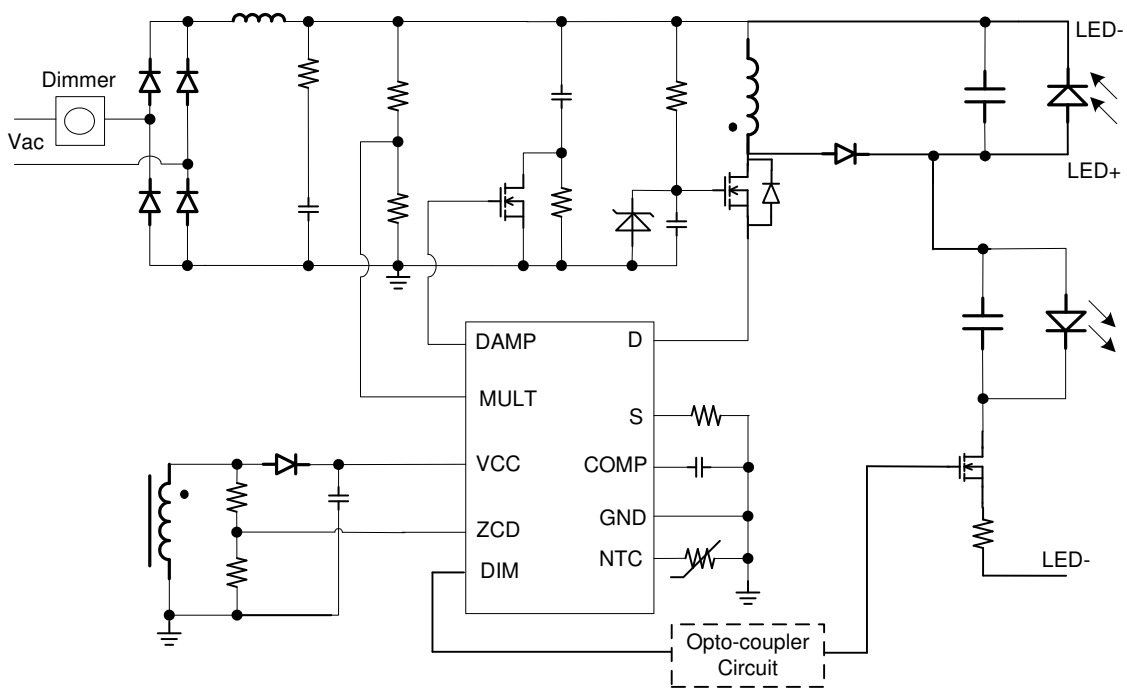

**SOIC14 and MSOP10**

**ORDERING INFORMATION**

Part Number	Package	Top Marking
MP4056GS*	SOIC-8	See Below
MP4056GK**	MSOP-10	
MP4056GSE***	SOIC-14	

- \* For Tape & Reel, add suffix -Z (e.g. MP4056GS-Z)
- \*\* For Tape & Reel, add suffix -Z (e.g. MP4056GK-Z)
- \*\*\* For Tape & Reel, add suffix -Z (e.g. MP4056GSE-Z)

**TOP MARKING (SOIC-8)**

MP4056  
 LLLLLLLL  
 MPSYWW

MP4056: first six digits of the part number;  
 LLLLLLLL: lot number;  
 MPS : MPS prefix;  
 Y: year code;  
 WW: week code:

**TOP MARKING (MSOP-10)**

YWLLL  
 M4056

Y: year code;  
 W: week code;  
 LLL: lot number;  
 M4056: first five digits of the part number;

**TOP MARKING (SOIC-14)**

MPSYYWW  
 MP4056  
 LLLLLLLL

MPS : MPS prefix;  
 YY: year code;  
 WW: week code;  
 MP4056: first six digits of the part number;  
 LLLLLLLL: lot number;

## PACKAGE REFERENCE

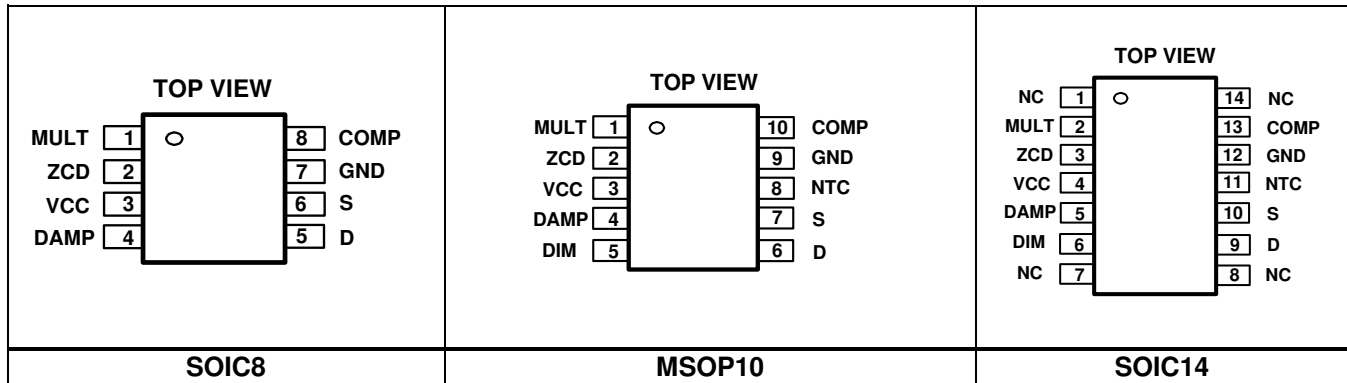

### ABSOLUTE MAXIMUM RATINGS <sup>(1)</sup>

Input Voltage VCC .....	-0.3V to +30V
Low-Side MOSFET Drain to Source Voltage .....	-0.7V to +30V
Damp Pin Voltage .....	-0.3V to +16.5V
Other Analog Inputs and Outputs..	-0.3V to 6.5V
ZCD Pin Current .....	-5mA to +5mA
Continuous Power Dissipation (T <sub>J</sub> = +25°C) <sup>(2)</sup>	
SOIC8.....	1.3W
SOIC14.....	1.45W
MSOP10.....	0.83W
Junction Temperature .....	150°C
Lead Temperature .....	260°C
Storage Temperature.....	-65°C to +150°C

### Recommended Operating Conditions <sup>(3)</sup>

Supply Voltage VCC .....	11V to 27V
Operating Junction Temp (T <sub>J</sub> )..	-40°C to +125°C

<i>Thermal Resistance</i> <sup>(4)</sup>	$\theta_{JA}$	$\theta_{JC}$
SOIC-8.....	96 .....	45 ... °C/W
MSOP-10 .....	150 .....	65 ... °C/W
SOIC-14.....	86 .....	38 ... °C/W

#### Notes:

- 1) Exceeding these ratings may damage the device.
- 2) The maximum allowable power dissipation is a function of the maximum junction temperature T<sub>J</sub> (MAX), the junction-to-ambient thermal resistance  $\theta_{JA}$ , and the ambient temperature T<sub>A</sub>. The maximum allowable continuous power dissipation at any ambient temperature is calculated by P<sub>D</sub> (MAX) = (T<sub>J</sub> (MAX)-T<sub>A</sub>)/ $\theta_{JA}$ . Exceeding the maximum allowable power dissipation will cause excessive die temperature, and the regulator will go into thermal shutdown. Internal thermal shutdown circuitry protects the device from permanent damage.
- 3) The device is not guaranteed to function outside of its operating conditions.
- 4) Measured on JESD51-7, 4-layer PCB.

## ELECTRICAL CHARACTERISTICS

Typical values are  $V_{CC} = 20V$ ,  $T_J = 25^\circ C$ , unless otherwise noted.

Minimum and maximum values are at  $V_{CC} = 20V$ ,  $T_J = -40^\circ C$  to  $+125^\circ C$ , unless otherwise noted, guaranteed by characterization.

Parameter	Symbol	Condition	Min	Typ	Max	Units
<b>Supply Voltage</b>						
Operating Range	$V_{CC}$	After turn on	11		27	V
VCC Upper Level: Internal Charging Circuit Stops and IC Turns On	$V_{CCH}$		9.5	10	10.5	V
VCC Lower Level: Internal Charging Circuit Triggers	$V_{CCL}$		8.55	9	9.45	V
VCC Re-charge and IC turns off Level in Fault Condition	$V_{CCEN}$	Fault condition	6.55	7	7.45	V
<b>Supply Current</b>						
VCC Charging Current from D	$I_{D\_CHARGE}$	$VD=16V, VCC=5V$	13	25	40	mA
Pull Down Current at VCC_UVLO	$I_{VCC\_PULL\_DOWN}$	$VCC=9V$ , Rising	0.95	1.25	1.8	mA
Quiescent Current	$I_Q$	No switching, $VCC=15V$		800	1300	$\mu A$
Quiescent Current at Fault	$I_{Q\_FAULT}$	Fault condition, IC latch, $VCC=15V$	220	340	620	$\mu A$
Operating Current	$I_{CC}$	$f_s = 70kHz, VCC=15V$		1	2	mA
<b>Multiplier</b>						
Linear Operation Range	$V_{MULT}$	$V_{COMP}$ from 1.9V to 4.9V	0		3	V
Gain	$K^{(5)}$	$V_{COMP}=2V, V_{MULT}=0.5V$	0.90	1.28	1.60	1/V
		$V_{COMP}=2V, V_{MULT}=1.5V$	0.90	1.25	1.60	1/V
		$V_{COMP}=2V, V_{MULT}=3V$	0.90	1.24	1.60	1/V
TRIAC Dimming Phase Off Detection Threshold	$V_{MULT\_OFF}$		0.08	0.10	0.12	V
TRIAC Dimming Phase On Detection Threshold	$V_{MULT\_ON}$		0.26	0.28	0.30	V
TRIAC Dimming Off Line-Cycle Blanking Ratio	$D_{OFF\_LEB}$		28%	30%	33%	
Dimming Pull-Down Turn on Threshold	$V_{MULT\_DP\_ON\_TL}$	Trailing edge dimmer	0.43	0.45	0.47	V
	$V_{MULT\_DP\_ON\_LD}$	Leading edge dimmer	0.22	0.25	0.28	V
Dimming Pull-Down Turn off Threshold	$V_{MULT\_DP\_OFF\_TL}$	Trailing edge dimmer	0.26	0.28	0.30	V
	$V_{MULT\_DP\_OFF\_LD}$	Leading edge dimmer	0.32	0.35	0.38	V
Leading Edge Dimming Detection Low Threshold	$V_{MULT\_LD\_LOW}$		0.08	0.10	0.12	V
Leading Edge Dimming Detection High Threshold	$V_{MULT\_LD\_HIGH}$		0.26	0.28	0.30	V

**ELECTRICAL CHARACTERISTICS** *(continued)*

Typical values are  $V_{CC} = 20V$ ,  $T_J = 25^\circ C$ , unless otherwise noted.

Minimum and maximum values are at  $V_{CC} = 20V$ ,  $T_J = -40^\circ C$  to  $+125^\circ C$ , unless otherwise noted, guaranteed by characterization.

Parameter	Symbol	Condition	Min	Typ	Max	Units
Trailing Edge Dimming Detection High Threshold	$V_{MULT\_TL\_HIGH}$	Rising, $V_{MULT\_PK} \geq 0.58V$ Falling, $V_{MULT\_PK} \geq 0.50V$	0.43	0.45	0.47	V
		Rising, $0.58V > V_{MULT\_PK} \geq 0.53V$ Falling, $0.50V > V_{MULT\_PK} \geq 0.45V$	0.38	0.4	0.42	V
		Rising, $0.53V > V_{MULT\_PK} \geq 0.48V$ Falling, $0.45V > V_{MULT\_PK} \geq 0.40V^{(6)}$		0.35		V
		Rising, $0.48V > V_{MULT\_PK} \geq 0.43V$ Falling, $0.40V > V_{MULT\_PK} \geq 0.35V^{(6)}$		0.3		V
		Rising, $0.43V > V_{MULT\_PK} \geq 0.38V$ Falling, $0.35V > V_{MULT\_PK} \geq 0.30V^{(6)}$		0.25		V
Trailing Edge Dimming Detection High Threshold Hysteresis	$V_{MULT\_TL\_H\_HYS}$			80		mV
Trailing Edge Dimming Detection Low Threshold	$V_{MULT\_TL\_LOW}$		0.08	0.10	0.12	V
Leading Edge dimmer detection Time threshold	$t_{LEADING}$	Rising	86	100	134	$\mu s$
Trailing Edge dimmer detection Time threshold	$t_{TRAILING}$	Falling	388	450	602	$\mu s$
<b>Error Amplifier</b>						
Reference Voltage	$V_{REF}$		0.400	0.414	0.428	V
Transconductance	$G_{EA}$	Guaranteed by design		130		$\mu A/V$
COMP Lower Clamp Voltage	$V_{COMPL\_LD}$	Leading edge dimmer	1.83	1.88	1.94	V
	$V_{COMPL\_TL}$	Trailing edge dimmer	1.53	1.58	1.64	V
	$V_{COMPL\_N}$	No dimmer	1.53	1.58	1.64	V
	$V_{COMPL\_NTC \leq 1.0V}$	$NTC \leq 1.0V$	1.44	1.49	1.55	V
Max. Source Current	$I_{COMP+}$			57		$\mu A$
Max. Sink Current without Dimmer	$I_{COMP-}$			200		$\mu A$
Sink Current at TRIAC Dimming Off	$I_{SINK\_DIM\_LD}$	Leading Edge Dimmer		85.50		$\mu A$
	$I_{SINK\_DIM\_TL}$	Trailing Edge Dimmer		155		$\mu A$

## ELECTRICAL CHARACTERISTICS *(continued)*

Typical values are  $V_{CC} = 20V$ ,  $T_J = 25^\circ C$ , unless otherwise noted.

Minimum and maximum values are at  $V_{CC} = 20V$ ,  $T_J = -40^\circ C$  to  $+125^\circ C$ , unless otherwise noted, guaranteed by characterization.

Parameter	Symbol	Condition	Min	Typ	Max	Units
<b>Current Sense Comparator</b>						
Leading-Edge-Blanking Time	$t_{LEB}$		350	500	750	ns
Over-Current-Protection Leading-Edge-Blanking Time	$t_{LEB\_OCP}$		260	350	550	ns
Over-Current-Protection Threshold	$V_{OCP}$		2.56	2.70	2.86	V
Current Sense Upper Clamp Voltage	$V_{S\_CLAMP\_H}$		1.97	2.07	2.17	V
Current Sense Lower Clamp Voltage	$V_{S\_CLAMP\_L}$		0.01	0.035	0.09	V
<b>Zero-Current Detector</b>						
Zero-Current-Detect Threshold	$V_{ZCD\_T}$	Falling Edge	0.27	0.30	0.33	V
Zero-Current-Detect Hysteresis	$V_{ZCD\_HYS}$		550	590	625	mV
ZCD Pin Short Circuit Threshold	$V_{ZCD\_SC}$		78	100	122	mV
ZCD Pin Short Circuit Blanking time	$t_{ZCD\_SC\_LEB}$			33		ms
Zero-Current-Detect LEB	$t_{ZCD\_LEB}$	Starts at Gate Turn Off when $V_{MULT\_O} \geq 0.25V$	1.90	2.30	3.36	$\mu s$
		Starts at Gate Turn Off when $V_{MULT\_O} < 0.25V$	0.95	1.18	1.68	$\mu s$
Over-Voltage Threshold	$V_{ZCD\_OVP}$		4.90	5.30	5.70	V
OVP Detect LEB	$t_{OVP\_LEB}$	Starts at Gate Turn Off when $V_{MULT\_O} \geq 0.25V$	1.90	2.30	3.36	$\mu s$
		Starts at Gate Turn Off when $V_{MULT\_O} < 0.25V$	0.95	1.18	1.68	$\mu s$
Minimum Off Time	$t_{OFF\_MIN}$	Normal	4	5.3	8	$\mu s$
		NTC $\leq 1.0V$		10		$\mu s$
Weak/Strong DP Mode detector current (for leading edge dimmer)	$I_{DP\_DET\_LD}$		140	180	220	$\mu A$
Strong DP Mode Enable Threshold (for leading edge dimmer)	$V_{EN\_DP\_STR\_LD}$		1.13	1.18	1.23	V
Weak/Strong DP Mode Detection Time (for leading edge dimmer)	$t_{DP\_DET\_LD}$		150	215	320	$\mu s$
<b>Starter</b>						
Start Timer Period	$t_{START}$		100	130	165	$\mu s$

## ELECTRICAL CHARACTERISTICS *(continued)*

Typical values are  $V_{CC} = 20V$ ,  $T_J = 25^\circ C$ , unless otherwise noted.

Minimum and maximum values are at  $V_{CC} = 20V$ ,  $T_J = -40^\circ C$  to  $+125^\circ C$ , unless otherwise noted, guaranteed by characterization.

Parameter	Symbol	Condition	Min	Typ	Max	Units
<b>Internal Main MOSFET</b>						
Breakdown Voltage	$BV_{DSS\_MAIN}$	$V_{GS=0}$	30			V
Drain-Source On-Resistor	$R_{DS(ON)\_MAIN}$	$I_D=100mA, T_J=25^\circ C,$		250		$m\Omega$
		$I_D=100mA, T_J=25^\circ C,$ $V_{CC}=V_{CCEN}+50mV$		250		$m\Omega$
<b>Internal OVP Pull Up MOSFET</b>						
Breakdown Voltage	$BV_{DSS\_D\_VCC}$		30			V
Continue Drain Current	$I_{D\_D\_VCC}$		10	17	27	mA
<b>Internal Dimming Pull Down Current Source</b>						
Strong Dimming Pull Down Current for leading edge dimmer	$I_{DP\_STRONG\_LD}$		27	35	43	mA
Weak Dimming Pull Down Current for leading edge dimmer	$I_{DP\_WEAK\_LD}$		8	10	12	mA
Pull Down Current for Trailing edge dimmer	$I_{DP\_TL}$		133	150	167	mA
Min Clamp Ratio of Pull Down Current for Trailing edge dimmer ( $I_{Min}/I_{Normal}$ )				13%		
<b>NTC</b>						
High Threshold Voltage	$V_{H\_NTC}$		1.14	1.2	1.36	V
Low Threshold Voltage	$V_{L\_NTC}$		0.70	0.80	0.90	V
Shutdown Threshold	$V_{SD\_NTC}$		0.32	0.38	0.44	V
Shutdown Voltage Hysteresis	$V_{SD\_NTC\_HSY}$		80	100	120	mV
Pull Up Current Source	$I_{PULL\_UP\_NTC}$		42	52	62	$\mu A$
Leakage Current	$I_{LEAKAGE\_NTC}$				1	$\mu A$
PWM Dimming Blanking Time	$t_{PWM\_LEB}$			20		ms
<b>DAMP</b>						
Turn Off Threshold	$V_{MULT\_DAMP\_OFF}$		0.22	0.25	0.28	V
Turn On Threshold	$V_{MULT\_DAMP\_ON}$		0.32	0.35	0.38	V
Pull Down Current	$I_{DAMP\_PULL\_DOWN}$	$V_{DAMP}=5V$	290	370	450	$\mu A$
Pull Up Current	$I_{DAMP\_PULL\_UP}$	$V_{DAMP}=0.3V$	70	90	110	$\mu A$
Upper Clamp Voltage	$V_{DAMP\_CLAMP\_UP}$		13	15	16.5	V
Min Pull Up Voltage	$V_{DAMP\_MIN}$	$V_{CC}=V_{CCEN}+50mV$	5.7			V



**ELECTRICAL CHARACTERISTICS** *(continued)*

Typical values are  $V_{CC} = 20V$ ,  $T_J = 25^{\circ}C$ , unless otherwise noted.

Minimum and maximum values are at  $V_{CC} = 20V$ ,  $T_J = -40^{\circ}C$  to  $+125^{\circ}C$ , unless otherwise noted, guaranteed by characterization.

Parameter	Symbol	Condition	Min	Typ	Max	Units
<b>DIM</b>						
Source Current	$I_{DIM\_SOURCE}$		2	3	4	mA
Sink Current	$I_{DIM\_SINK}$		1.5	2.8	4	mA
High Level	$V_{DIM\_HIGH}$		5.0		6.1	V
Low Level	$V_{DIM\_LOW}$				0.3	V
<b>Thermal Shutdown</b>						
Thermal Shutdown Threshold <sup>(6)</sup>	$T_{SD}$			150		$^{\circ}C$
Thermal Shutdown Recovery Hysteresis <sup>(6)</sup>	$T_{HYS}$			25		$^{\circ}C$

**Notes:**

5) The multiplier output is given by:  $V_s = K \cdot V_{MULT} \cdot (V_{COMP} - 1.5)$

6) Guaranteed by characterization.

## TYPICAL CHARACTERISTICS

**Reference Voltage vs.  
Junction Temperature**

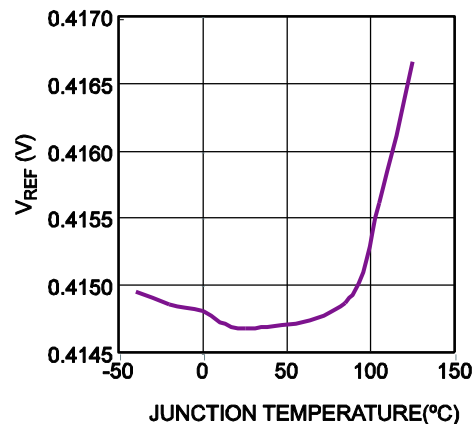

## TYPICAL PERFORMANCE CHARACTERISTICS

Based on the EVB model: EV4056-K-00B, Non-isolated Buck-Boost converter, 230VAC/50Hz input, 36V/167mA output, TA=25°C, unless otherwise noted.

### Conducted EMI L-Line

V<sub>IN</sub> = 230VAC/50Hz, Full Load,  
RBW = 9kHz, MT = 20ms

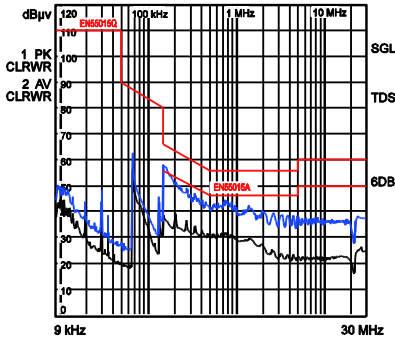

### Conducted EMI N-Line

V<sub>IN</sub> = 230VAC/50Hz, Full Load,  
RBW = 9kHz, MT = 20ms

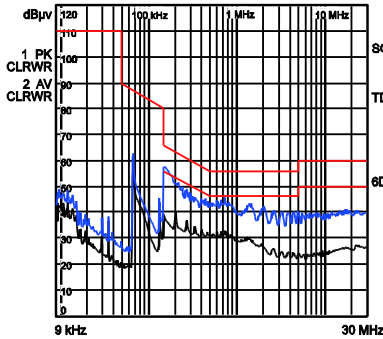

### Radiated EMI

Tested by CDN,  
V<sub>IN</sub>=230VAC/50Hz, Full Load

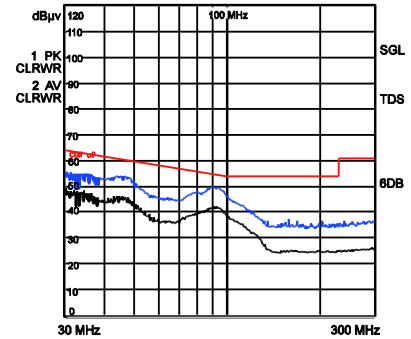

### Dimming Curve

V<sub>IN</sub>=230VAC/50Hz Full load,  
with different dimmers

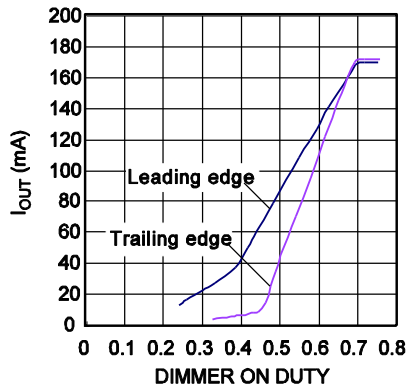

### Line Regulator

Full Load

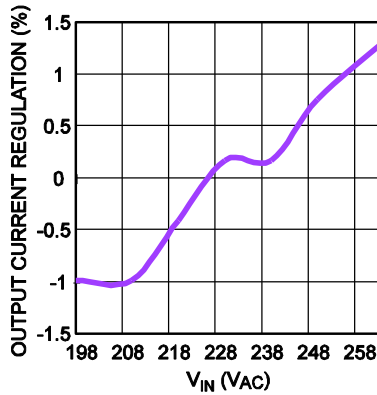

### Efficiency vs. V<sub>IN</sub>

V<sub>IN</sub>=(198-265)VAC/50Hz, Full Load

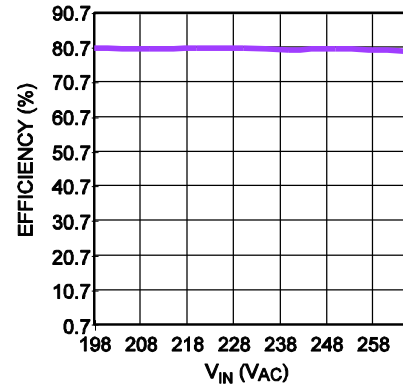

### PF vs. V<sub>IN</sub>

V<sub>IN</sub>=(198-265)VAC/50Hz, Full Load

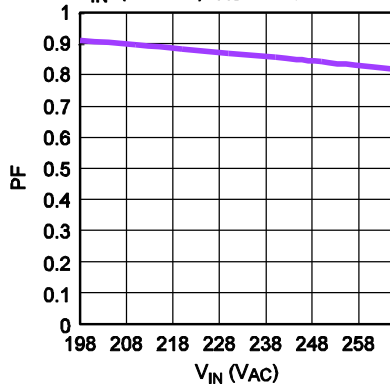

### THD vs. V<sub>IN</sub>

V<sub>IN</sub>=198-265VAC/50Hz, Full load

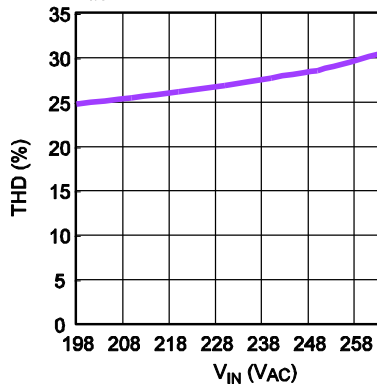

## TYPICAL PERFORMANCE CHARACTERISTICS *(continued)*

Based on the EVB model: EV4056-K-00B, Non-isolated Buck-Boost converter, 230VAC/50Hz input, 36V/167mA output, TA=25°C, unless otherwise noted.

**Input Voltage and Current**  
VIN=230VAC/50Hz, Full Load

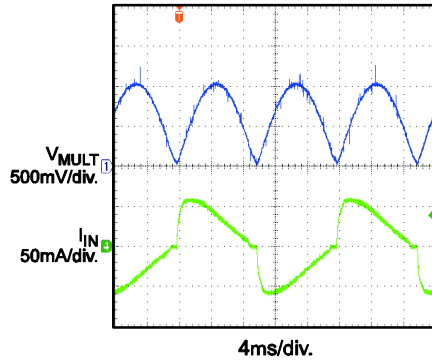

**Steady State**  
VIN=230VAC/50Hz, Full Load

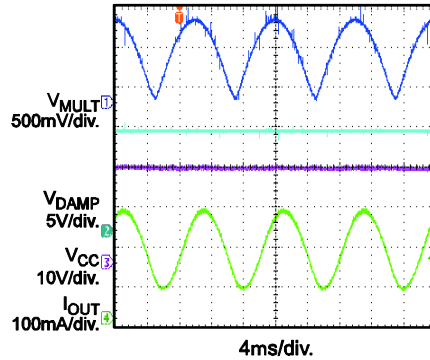

**Steady State**  
VIN=230VAC/50Hz, Full Load

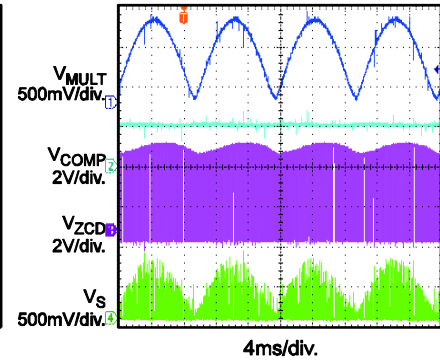

**VIN Start Up**  
VIN=230VAC/50Hz, Full Load

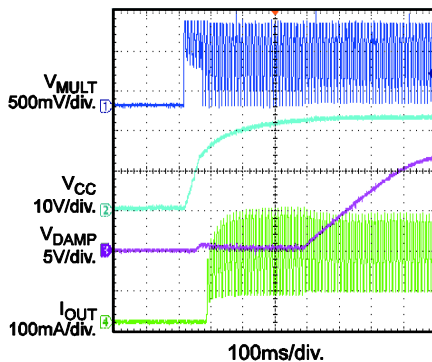

**Dimming Performance**  
Max dimming on phase with leading-edge dimmer  
VIN=230VAC/50Hz, with dimmer

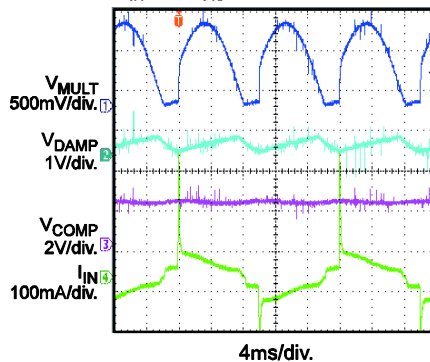

**Dimming Performance**  
Min dimming on phase with leading-edge dimmer  
VIN=230VAC/50Hz, with dimmer

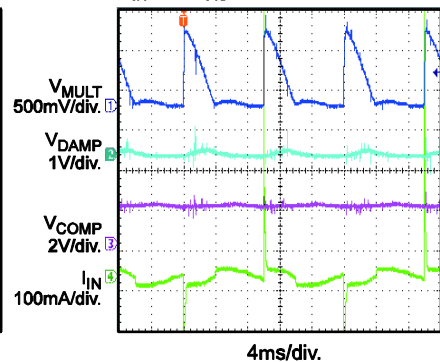

**Dimming Performance**  
Max dimming on phase with trailing-edge dimmer  
VIN=230VAC/50Hz, with dimmer

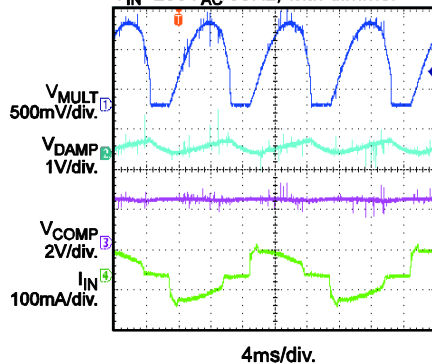

**Dimming Performance**  
Min dimming on phase with trailing-edge dimmer  
VIN=230VAC/50Hz, with dimmer

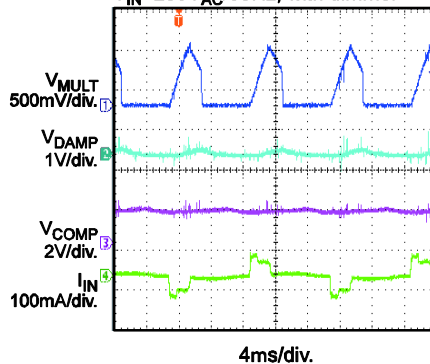

**OVP**  
LED Load Open then Recovery  
VIN=230VAC/50Hz, Full Load

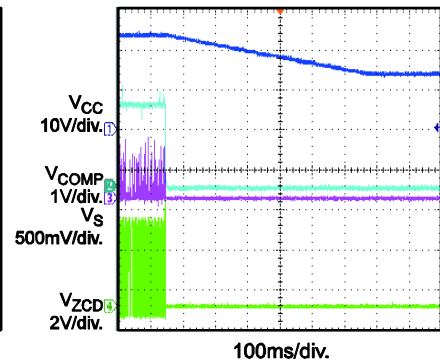

## TYPICAL PERFORMANCE CHARACTERISTICS *(continued)*

Based on the EVB model: EV4056-K-00B, Non-isolated Buck-Boost converter, 230VAC/50Hz input, 36V/167mA output, TA=25°C, unless otherwise noted.

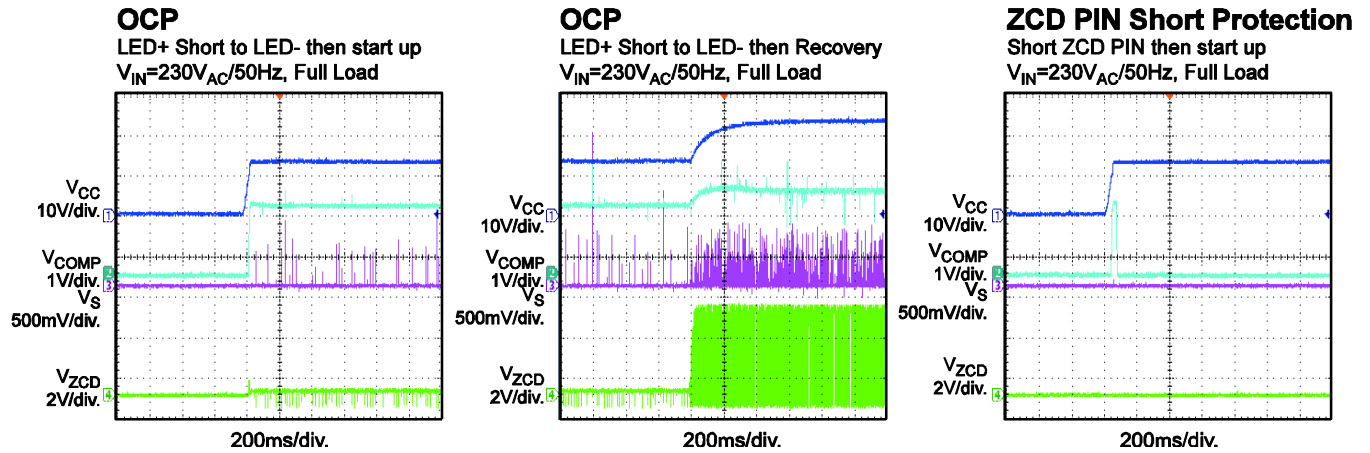

## PIN FUNCTIONS

Pin #			Name	Description
SOIC8	SOIC14	MSOP10		
1	2	1	MULT	One of the Internal Multiplier's Inputs. Connect to the tap of resistor divider from the rectified voltage of the AC line. The half-wave sinusoid signal on this pin provides a reference signal for the internal current control loop. The MULT is also used for dimmer type and phase detection.
2	3	2	ZCD	Zero-Current Detection. A negative going edge triggers the internal MOSFET's turn-on signal. Connect to the tap of a resistor divider from the auxiliary winding to GND. The over-voltage condition is detected from ZCD. Over-voltage occurs if $V_{ZCD}$ exceeds the over-voltage-protection (OVP) threshold after a blanking time when the internal MOSFET turns off. The ZCD is also used to select the Strong/Weak Dimming Pull Down Current in leading edge dimming. Besides, the ZCD itself has short circuit protection to prevent the device damage when output is open and ZCD pin is short.
3	4	3	VCC	Supply Voltage. Supply power for both the control signal and the internal MOSFET's gate driver. Connect this pin to an external bulk capacitor—typically 22 $\mu$ F.
4	5	4	DAMP	Gate Control pin of the external Damping MOSFET.
NA	6	5	DIM	Gate driver. DIM is used to control the color temperature and brightness for warm sunset dimming or drive an external dummy load to enlarge the dimming depth. It is the compliment signal to the TRIAC dimming; i.e. as TRIAC commands less LED current, DIM duty cycle commands more.
5	9	6	D	Internal Low-Side main MOSFET Drain. It is connected to the source of the external high-side MOSFET. This pin is also internally connected to VCC through a diode and a JFET to form an internal charging circuit for VCC. There is an internal series-connected MOS and diode to pull up the D to VCC at fault condition to turn off the main switch reliably. There is an intelligent dimming pull down current source on this pin.
6	10	7	S	Internal Low-Side main MOSFET Source. Connect a resistor from this pin to GND to sense the internal MOSFET current. An internal comparator compares the resulting voltage to the internal sinusoid shaped current reference signal to determine when the MOSFET turns off. If the voltage exceeds the upper current-clamp threshold after the leading edge blanking time, the gate signal turns off. Over-current occurs if S exceeds OCP threshold during the gate-on interval after the OCP lead edge blanking time.
NA	11	8	NTC	LED temperature protection input. Connecting a NTC resistor from this pin to GND reduces the output current in high ambient temperature to protect the LED and driver. Analog dimming is accomplished with an external PWM signal through a resistor. A 1k $\Omega$ resistor is recommended.
7	12	9	GND	Ground. Current return of the control signal and power signal.
8	13	10	COMP	Loop Compensation. Connect COMP to a compensation network (typically a capacitor to ground) to stabilize the LED driver and accurately control the LED driver current.
	1,7,8,14		NC	

## FUNCTION DIAGRAM

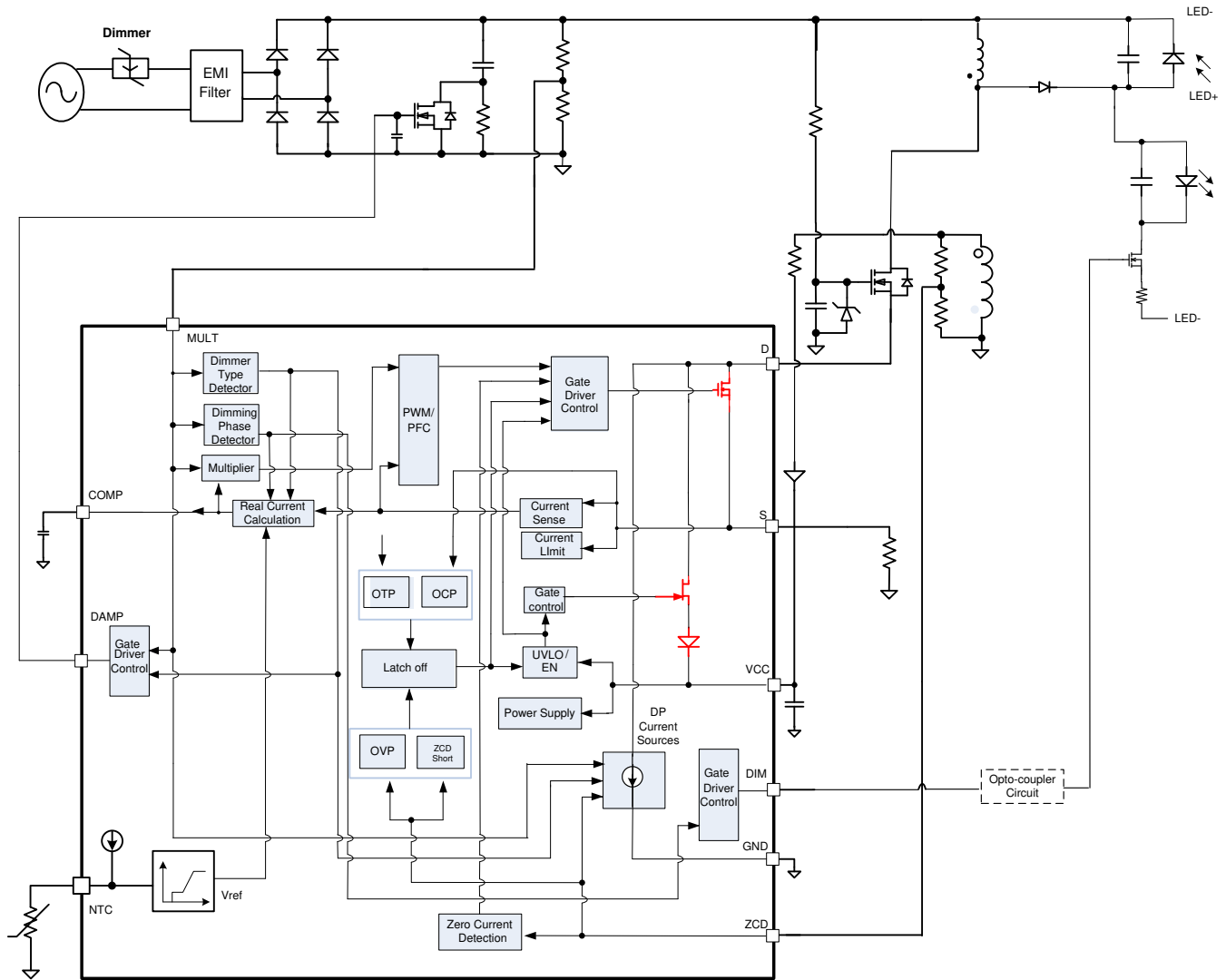

Figure 1: MP4056 Function Diagram

## OPERATION

The MP4056 is a non-isolated TRIAC and PWM dimmable, offline LED controller designed for high-performance LED lighting. The adaptive dimmer type detection and phase-cut-based dimming control bring good dimmer compatibility and deep dimming range. It achieves a high power factor to eliminate noise pollution on the AC line. The integrated VCC charging circuit achieves fast start-up without any perceptible delay. The programmable thermal current fold back function prolongs the life time of the LED. Because duty ratio varies inversely to the dimming cycle, it easily supports color temperature and brightness control for warm sunset dimming applications. The MP4056 also supports analog dimming with PWM input.

### Boundary-Conduction Mode

During the external MOSFET on time ( $t_{ON}$ ), the rectified input voltage ( $V_{BUS}$ ) is applied to the inductor ( $L_m$ ), and the inductor current ( $I_{Lm}$ ) increases linearly from zero to the peak value ( $I_{pk}$ ). Then the external MOSFET turns off. The energy stored in  $L_m$  forces the rectifier diode to turn on, and the inductor current decreases linearly from the peak value to zero. When the current decreases to zero, the voltage drop on the main MOSFET drain-to-source falls and oscillates. The oscillation frequency is determined by the inductor and the combined parasitic capacitances. The resonance is reflected on the auxiliary winding (see Figure 2).

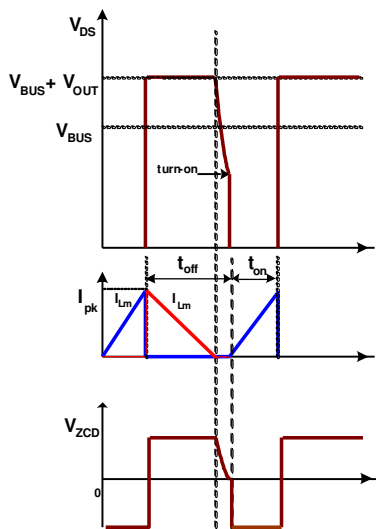

**Figure 2: Boundary-Conduction Mode**

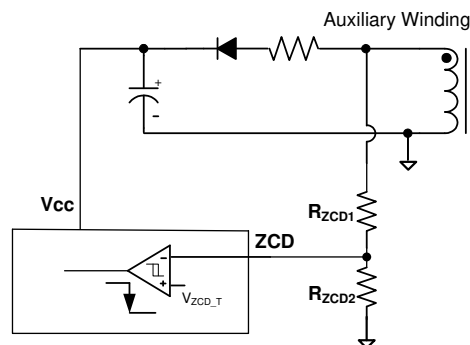

**Figure 3: Zero-Current Detector**

The zero-current detector generates the external MOSFET turn-on signal when the ZCD voltage falls below  $V_{ZCD\_T}$  after a blanking time  $t_{ZCD\_LEB}$  and ensures the MOSFET turns on at a relatively low voltage (see Figure 3).

As a result, there are relatively small switching on losses and no diode reverse-recovery losses. This ensures high efficiency and low EMI noise

### Real-Current Control

The proprietary real-current-control method allows the MP4056 to control the output LED current based on the inductor current information. The approximate output LED mean current can be calculated as:

$$I_o \approx \frac{V_{REF}}{2 \cdot R_s}$$

Where:

- $V_{REF}$  is the internal reference voltage (typically 0.414), and
- $R_s$  is the sense resistor between the internal MOSFET source and GND.

### Power-Factor Correction

The MULT pin is connected to the tap of a resistor divider from the rectified instantaneous line voltage, driving a sinusoidal multiplier output. This signal provides the reference for the current comparator, which shapes the primary-peak current into a sinusoid and has the same phase with the input line voltage. This guarantees a high power factor.



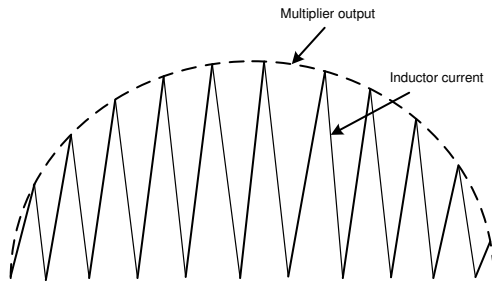

**Figure 4: Power-Factor Correction**

The multiplier’s maximum output voltage to the current comparator is clamped to  $V_{S\_CLAMP\_H}$  to limit the cycle-by-cycle current. The multiplier’s minimum output voltage is clamped to  $V_{S\_CLAMP\_L}$  to ensure a turn-on signal during the TRIAC dimming OFF interval, which pulls down the rectifier input voltage and accurately detects the dimming phase.

**VCC Timing Sequence**

The VCC timing sequence is shown in Figure 5. Initially, VCC charges through the internal charging circuit from the AC line. When VCC reaches  $V_{CCH}$ , the internal charging circuit stops charging, the control logic initializes and the internal main MOSFET begins to switch. The auxiliary winding takes over the power supply. However, the initial auxiliary-winding positive voltage may not be large enough to charge VCC, causing VCC to drop. Instead, if the VCC voltage drops below  $V_{CCL}$  threshold, the internal charging circuit triggers and charges VCC to  $V_{CCH}$  again. This cycle repeats until the auxiliary winding voltage is high enough to power VCC.

If any fault occurs during this time, the switching and the internal charging circuit stops, and VCC drops. When VCC decreases below  $V_{CCEN}$ , the internal re-charge is enabled to auto-restart.

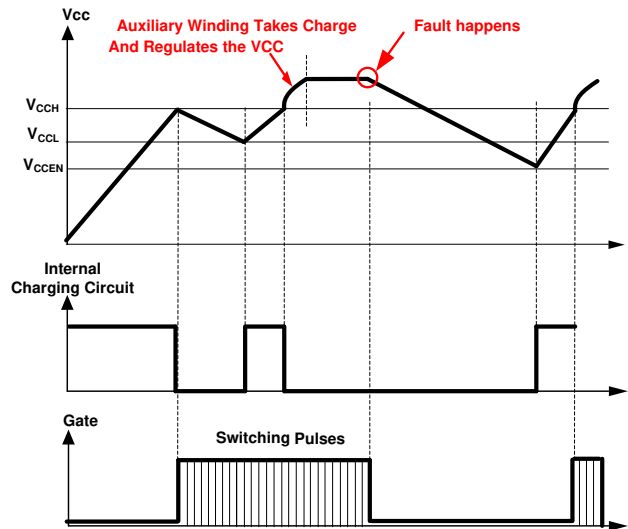

**Figure 5: VCC Timing Sequence**

**Auto Start**

The MP4056 contains an auto starter that starts timing when the MOSFET turns off. If ZCD fails to send a turn-on signal after  $t_{START}$ , the starter will automatically send a turn-on signal to avoid unnecessary shutdown.

**Minimum OFF Time**

MP4056 operates with a variable switching frequency; the frequency changes with the instantaneous input line voltage. In order to limit the maximum frequency and get a good EMI performance, the MP4056 employs an internal minimum off time.

**Leading-Edge Blanking**

In order to avoid premature switching-pulse termination due to the parasitic capacitances discharging when the MOSFET turns on, an internal leading-edge-blanking (LEB) time is introduced on S. The current comparator blocks the input path from S pin during the blanking time. Figure 6 shows the leading-edge blanking.

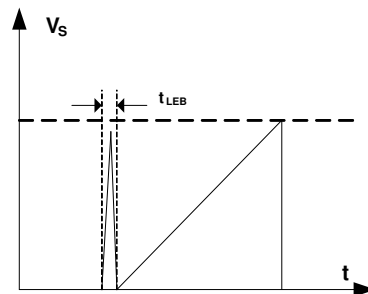

**Figure 6: Leading-Edge Blanking**

**Output Over-Voltage Protection (OVP)**

Output over-voltage protection (OVP) prevents the components from over-voltage damage. The auxiliary winding voltage’s positive plateau is proportional to the output voltage, so the OVP block monitors this auxiliary winding voltage to apply an OVP function, as shown in Figure 7. Once the ZCD pin voltage exceeds  $V_{ZCD\_OVP}$ , the OVP signal is triggered, the gate driver turns off, the IC works in its quiescent current mode. When the VCC voltage drops below the UVLO threshold, the IC shuts down and the system restarts. The output OVP set point is calculated as:

$$V_{out\_ovp} \cdot \frac{N_{aux}}{N_{sec}} \cdot \frac{R_{ZCD2}}{R_{ZCD1} + R_{ZCD2}} = V_{ZCD\_OVP}$$

Where:

$V_{out\_ovp}$  is the output OVP threshold,

$N_{aux}$  is the turns of auxiliary winding, and

$N_{sec}$  is the turns of secondary winding

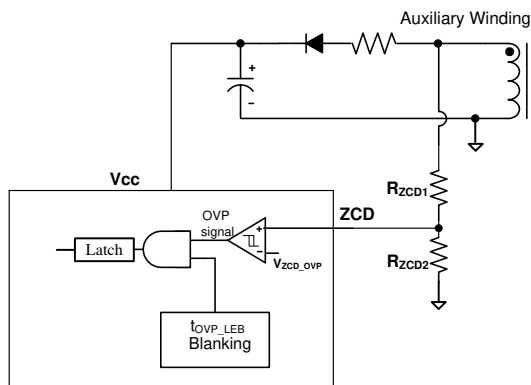

**Figure 7: OVP Sampling Circuit**

To avoid switch-off spikes mis-triggering OVP, OVP sampling has a  $t_{OVP\_LEB}$  blanking period, as shown in Figure 8.

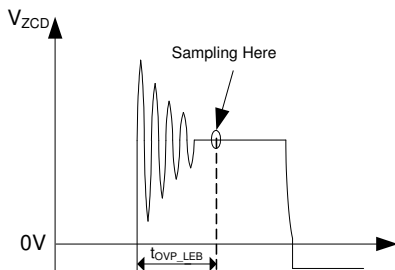

**Figure 8: ZCD Voltage and OVP Sampling**

**Cycle by Cycle Current Limit**

There is cycle by cycle current limit on the S pin, when the voltage on S pin reaches  $V_{S\_CLAMP\_H}$  after a blanking time, the switching will turn off to limit the peak current value.

**Over-Current Protection (OCP)**

The S pin has an internally-integrated comparator for inductor OCP. When the gate is on, the comparator is enabled. Over-current occurs when  $V_S$  exceeds  $V_{OCP}$  after a blanking time. The IC shuts down and restarts after VCC drops below UVLO. The OCP function block diagram is shown in Figure 9.

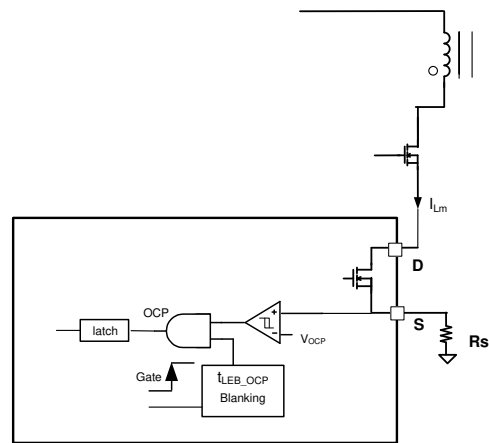

**Figure 9: Over-Current Protection Circuit**

**LED Short Circuit Protection (SCP)**

When the LED Short Circuit occurs, IC reduces the switching frequency to 7kHz. The output power at this condition is limited to a safe range.

**ZCD Pin Short Circuit Protection**

If ZCD pin voltage is less than  $V_{ZCD\_SC}$  lasts longer than  $t_{ZCD\_SC\_LEB}$ , it is recognized as ZCD pin short circuit. The MP4056 stops the switching until VCC drops below UVLO and restarts.

This prevents the components from over-voltage damage if LED load opens while ZCD shorts at the same time.

### Thermal Shutdown

To prevent IC from thermal damage, the MP4056 latches off the switching cycle when the junction temperature is higher than 150°C. When the VCC drops below UVLO, it restarts again.

### Adaptive Dimmer Type Detection

The MP4056 integrates adaptive dimmer type detection to accurately detect which kind of dimmer is connected at the system start-up, leading edge dimmer, trailing edge dimmer or no dimmer. The MP4056 works in different modes depending on these dimmer types to achieve the best dimmer compatibility at the highest performance.

### Phase-Cut-Based Dimming Control

The MP4056 implements phase-cut-based dimming control (both for leading edge and trailing edge dimmers). For leading edge dimmers, most of them are TRIAC-based. The TRIAC dimmer usually consists of a bi-directional SCR and an adjustable turn on phase. Figure 10 shows the leading-edge TRIAC dimmer waveforms.

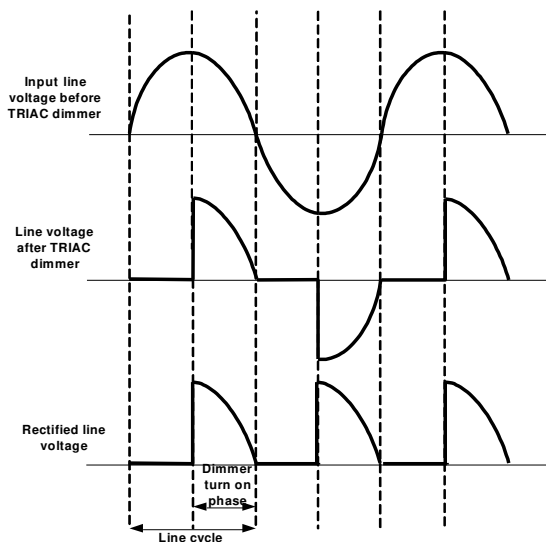

**Figure 10: Leading Edge Dimmer Waveforms**

For trailing edge dimmers, the waveforms are shown in Figure 11.

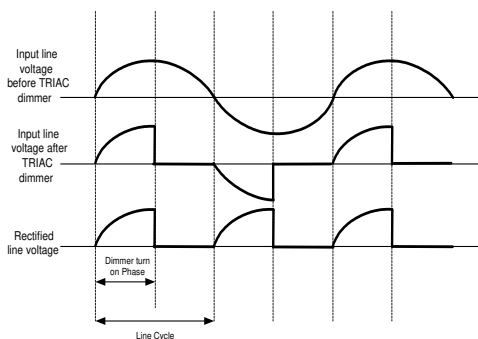

**Figure 11: Trailing Edge Dimmer Waveforms**

MP4056 detects the dimming turn-on cycle through the MULT pin. Based on the turn-on cycle, the control circuitry adjusts the internal reference voltage. MULT voltage exceeding  $V_{MULT\_ON}$  is recognized as a dimmer turn-on signal, MULT voltage below  $V_{MULT\_OFF}$  is recognized as a dimmer turn-off signal. MP4056 has a 30% line-cycle-detection blanking time at each line cycle. The real phase detector output adds this blanking time to determine the reference voltage, if it is higher than 100%, the reference voltage is clamped to 100%, as shown in Figure 12. This means if the turn-on cycle exceeds 70% of the line cycle, the reference maintains the maximum current value, which keeps the maximum output current with different dimmers is almost the same with the rated output current.

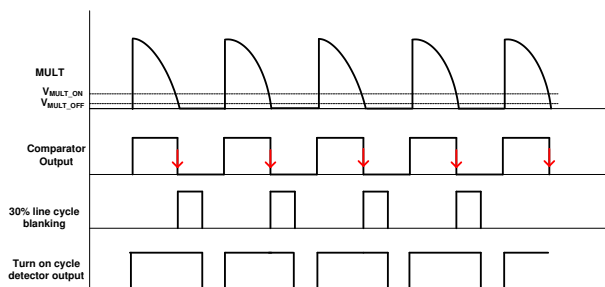

**Figure 12: Dimming Turn-On Cycle Detector**

When the turn-on cycle decreases to less than 70%, the internal reference voltage decreases, lowers the output current. As the dimming turn-on cycle decreases, the COMP voltage also decreases. For leading edge dimmers, once the COMP voltage reaches  $V_{COMPL\_LD}$ , it is clamped. The output current decreases slowly to maintain the TRIAC holding current and avoid random flicker. Figure 13 shows the relationship between the leading edge dimming turn-on phase and output current.

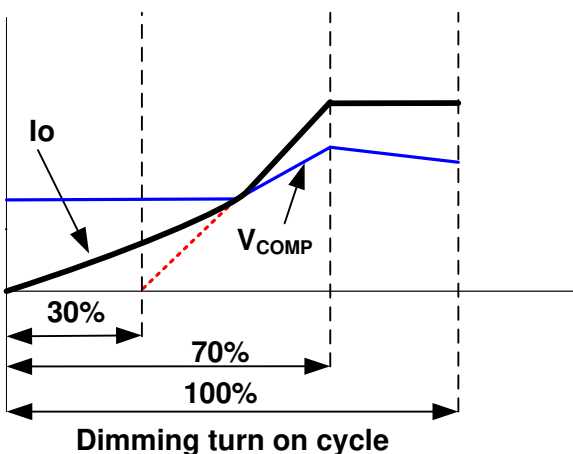

**Figure 13: Leading Edge Dimming Curve**

For trailing edge dimmers, there is no holding current, the COMP voltage is clamped at a lower level  $V_{COML\_TL}$  to get deeper dimming depth. Figure 14 shows the relationship between the trailing edge dimming turn-on phase and output current.

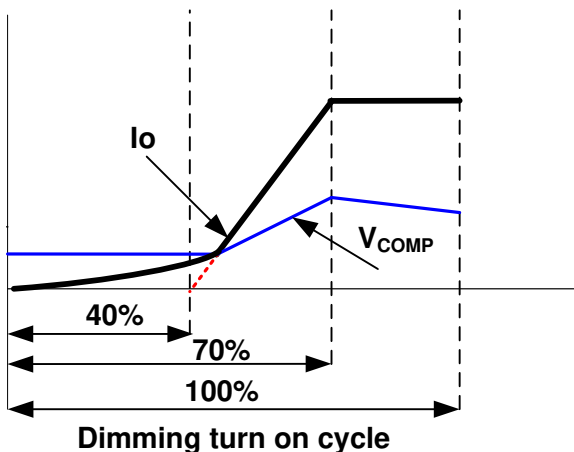

**Figure 14: Trailing Edge Dimming Curve**

### Dimming Pull-Down Current Source

There are three kinds of dimming pull down current source in MP4056. The  $I_{DP\_TL}$  current source is for trailing edge dimming, the other two (weak/strong) current sources are for leading edge dimming. The dimming pull down current is used to pull down the rectified line voltage to zero quickly to avoid any mis-detection on the MULT pin.

If the leading edge dimmer is detected, the dimming pull-down current source turns on when the MULT decreases to  $V_{MULT\_DP\_ON\_LD}$  and turns off until the MULT increases to  $V_{MULT\_DP\_OFF\_LD}$ . If trailing edge dimmer is detected, the dimming pull-down current source turns on when the

MULT decreases to  $V_{MULT\_DP\_ON\_TL}$  and turns off until the MULT increases to  $V_{MULT\_DP\_OFF\_TL}$ .

The weak/strong dimming pull down current source is selected through different resistance on the ZCD pin. Figure 15 shows the selected logic:

$$\text{If } I_{DP\_DET\_LD} * (R1+R2//R3) \geq V_{EN\_DP\_STR\_LD}$$

Strong dimming pull-down current source is selected; otherwise, weak dimming pull down current source is selected.

In real application design, the weak/strong dimming pull down current selection is related to the detailed application SPEC.

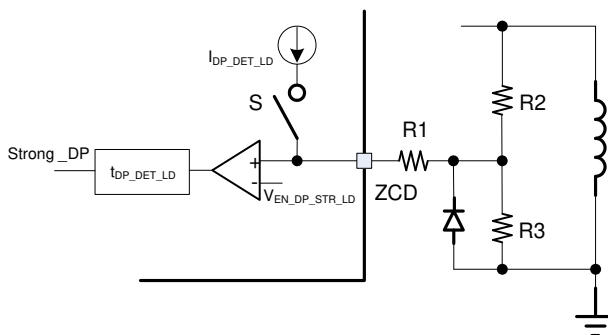

**Figure 15: Weak/Strong Dimming Pull Down Current Source Selection**

### Damping Circuit Control

If a leading edge dimmer or trailing edge dimmer is detected, the damping circuit is enabled to limit the inrush current at the moment dimmer turns on. If no dimmer is detected, the damping circuit is disabled by pulling up the damp pin voltage so the damping resistor is shorted by the damping MOSFET. The damp pin voltage begins to be pulled up if MULT voltage increases higher than  $V_{MULT\_DAMP\_ON}$  and begins to be pulled down when MULT voltage decreases lower than  $V_{MULT\_DAMP\_OFF}$ . The maximum pull up current source is  $100\mu A$  while the max pull down current source is  $400\mu A$ .

### Color Temperature and Brightness Control for Warm Sunset Dimming application

The color temperature and brightness control circuit is shown in figure 16.

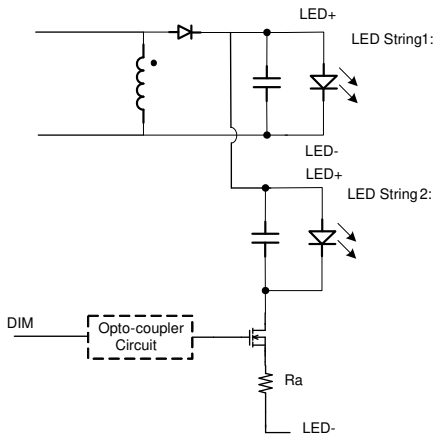

**Figure 16: Color Temperature and Brightness Control Circuit**

The DIM pin of MP4056 outputs a driving signal for an external MOSFET. The DIM signal logic waveforms are shown in Figure 17.

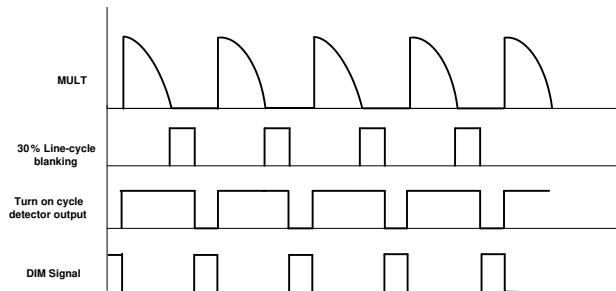

**Figure 17: Dim Signal Logic**

DIM turn-on signal is the compliment signal of the dimming turn-on signal. This means the longer the dimming turn-on cycle, the smaller the DIM turn-on cycle. When the dimming turn-on cycle is greater than 70%, the DIM stays low, and the output current flows only through the 1<sup>st</sup> LED string. As the dimming turn-on cycle decreases, the DIM turn-on duty cycle proportionally increases the 2<sup>nd</sup> LED string current. The total current through the 1<sup>st</sup> string and the 2<sup>nd</sup> string stays constant. This current balance achieves color temperature and brightness control. The maximum current through 2<sup>nd</sup> string is adjusted by changing the resistance of Ra.

**Dimming Depth Enlargement**

Driving a MOSFET to pull down a resistor from auxiliary winding to GND forms a dummy load, which to help distribute the output current. The DIM pin working timing makes the smaller dimming duty cycle is, the bigger dummy load

distribution current is, the dimming depth is enlarged. The dimming depth enlargement circuit is shown in figure 18.

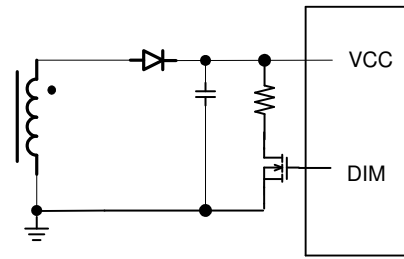

**Figure 18: Dimming Depth Enlargement circuit**

**Programmable Thermal Fold-back (NTC)**

The NTC pin is used as the LED programmable thermal fold-back. A NTC resistor is connected to this pin directly to monitor the LED temperature. The LED current reduces as the voltage drops on NTC. Figure 19 shows the NTC curve.

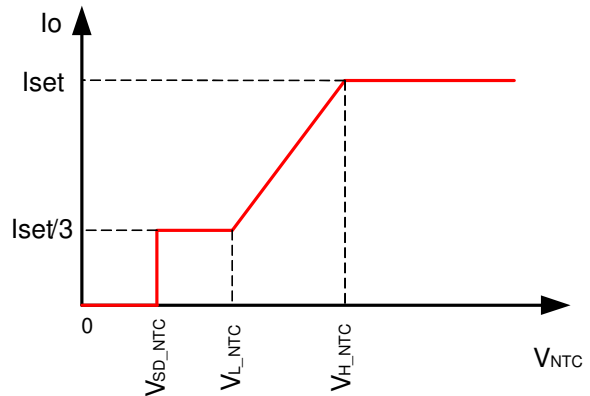

**Figure 19: NTC Curve**

If the voltage on the NTC pin is lower than the  $V_{SD\_NTC}$ , the LED current drops to the minimum value. The minimum output current is determined by the minimum on time (LEB time) of the main MOSFET.

**Analog dimming with PWM Input**

The MP4056 enables direct control of analog dimming. Applying a PWM signal (>200Hz) on NTC achieves analog dimming. The output current will linearly change with the PWM duty cycle from maximum to minimum. This feature dramatically reduces the BOM cost for the PWM dimming system.

## TYPICAL APPLICATION CIRCUITS

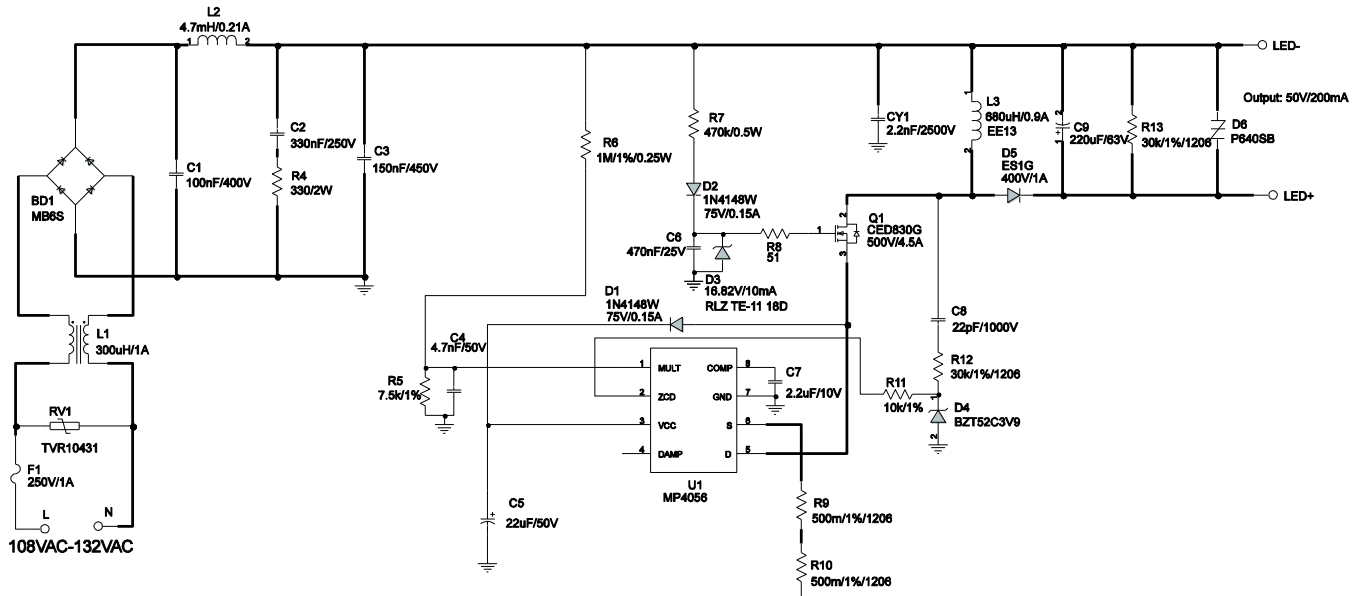

Figure 20: GU10 Bulb Driver, 120VAC/60Hz Input,  $V_O = 50V$ ,  $I_O = 200mA$ , Buck-Boost Converter, Low Bom Cost, EVB Model: EV4056-S-00A

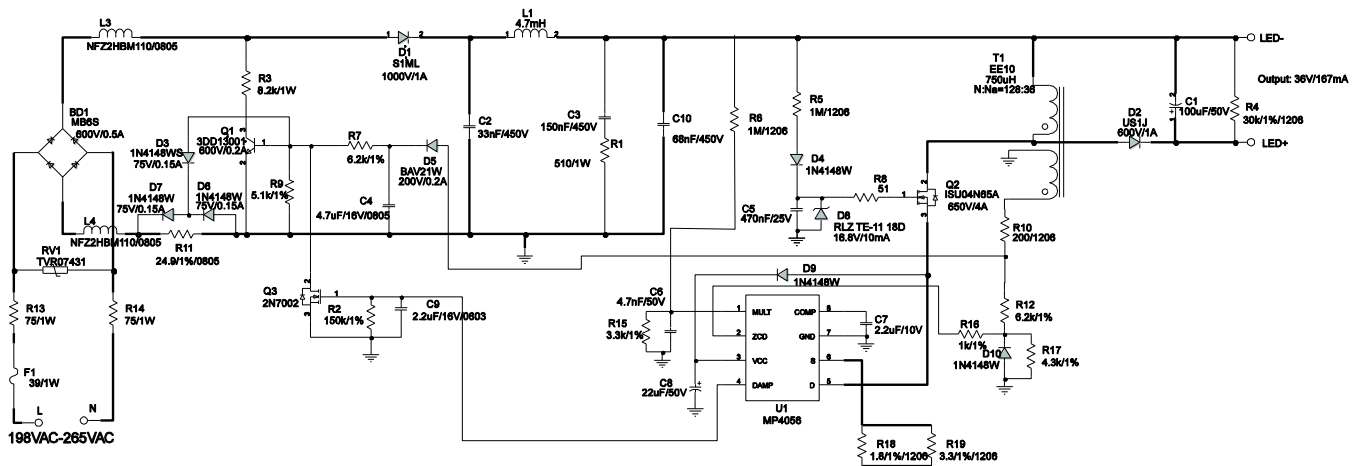
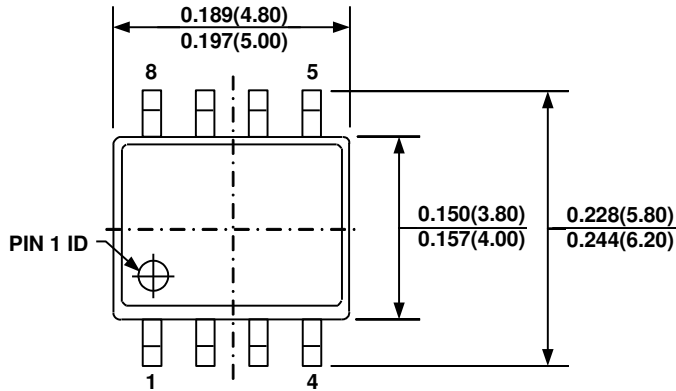

Figure 21: GU10 Bulb Driver, 230VAC/50Hz Input,  $V_O = 36V$ ,  $I_O = 167mA$ , Buck-Boost Converter, High Performance, EVB Model: EV4056-S-00B



**PACKAGE INFORMATION**

**SOIC8**



**TOP VIEW**

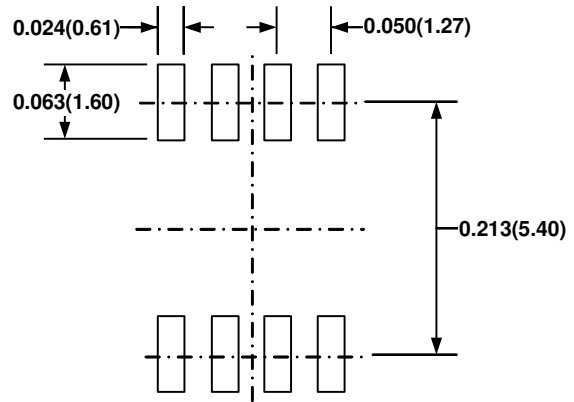

**RECOMMENDED LAND PATTERN**

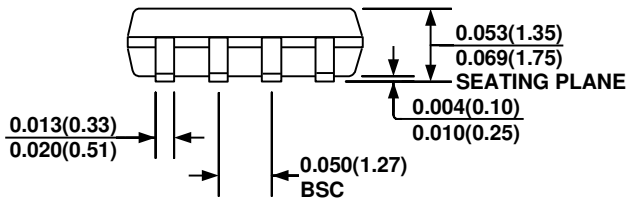

**FRONT VIEW**

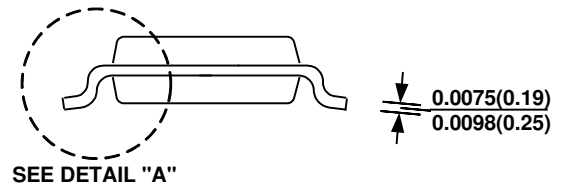

**SIDE VIEW**

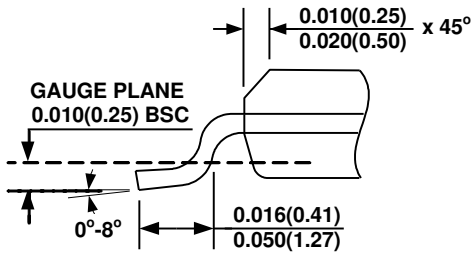

**DETAIL "A"**

**NOTE:**

- 1) CONTROL DIMENSION IS IN INCHES. DIMENSION IN BRACKET IS IN MILLIMETERS.
- 2) PACKAGE LENGTH DOES NOT INCLUDE MOLD FLASH, PROTRUSIONS OR GATE BURRS.
- 3) PACKAGE WIDTH DOES NOT INCLUDE INTERLEAD FLASH OR PROTRUSIONS.
- 4) LEAD COPLANARITY (BOTTOM OF LEADS AFTER FORMING) SHALL BE 0.004" INCHES MAX.
- 5) DRAWING CONFORMS TO JEDEC MS-012, VARIATION AA.
- 6) DRAWING IS NOT TO SCALE.



**MSOP10**

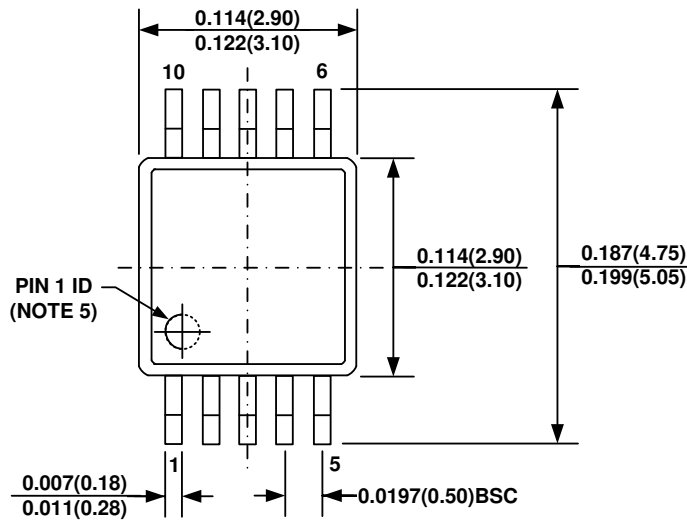

**TOP VIEW**

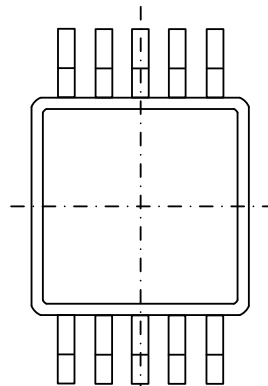

**BOTTOM VIEW**

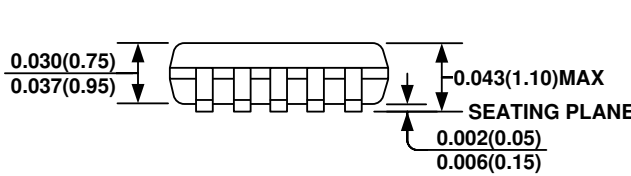

**FRONT VIEW**

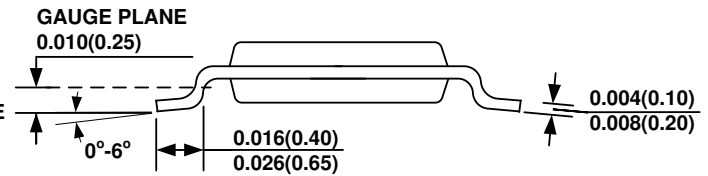

**SIDE VIEW**

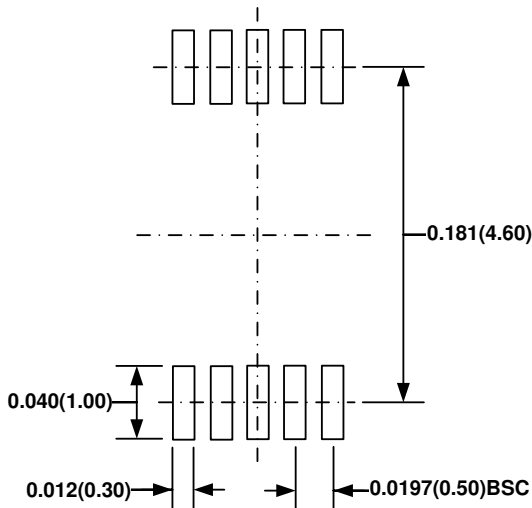

**RECOMMENDED LAND PATTERN**

**NOTE:**

- 1) CONTROL DIMENSION IS IN INCHES. DIMENSION IN BRACKET IS IN MILLIMETERS.
- 2) PACKAGE LENGTH DOES NOT INCLUDE MOLD FLASH, PROTRUSION OR GATE BURR.
- 3) PACKAGE WIDTH DOES NOT INCLUDE INTERLEAD FLASH OR PROTRUSION.
- 4) LEAD COPLANARITY (BOTTOM OF LEADS AFTER FORMING) SHALL BE 0.004" INCHES MAX.
- 5) PIN 1 IDENTIFICATION HAS THE HALF OR FULL CIRCLE OPTION.
- 6) DRAWING MEETS JEDEC MO-817, VARIATION BA.
- 7) DRAWING IS NOT TO SCALE.

**SOIC-14**

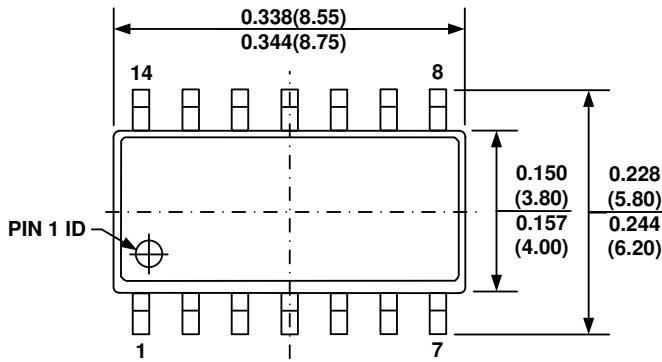

**TOP VIEW**

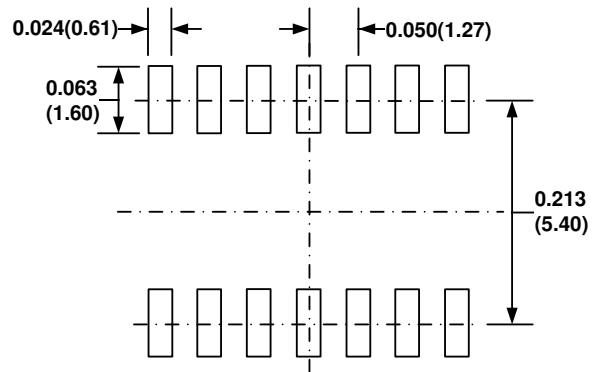

**RECOMMENDED LAND PATTERN**

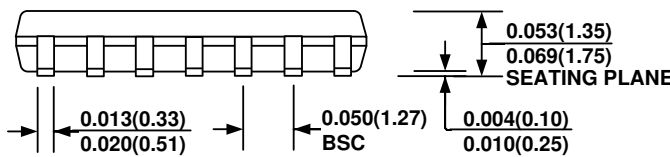

**FRONT VIEW**

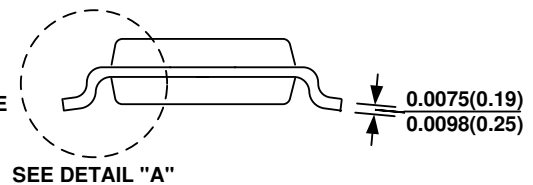

**SIDE VIEW**

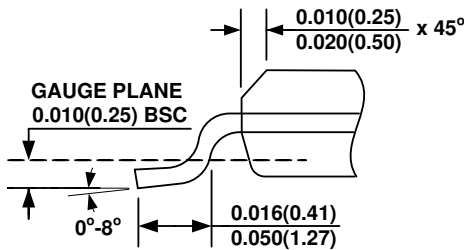

**DETAIL "A"**

**NOTE:**

- 1) CONTROL DIMENSION IS IN INCHES. DIMENSION IN BRACKET IS IN MILLIMETERS.
- 2) PACKAGE LENGTH DOES NOT INCLUDE MOLD FLASH, PROTRUSIONS OR GATE BURRS.
- 3) PACKAGE WIDTH DOES NOT INCLUDE INTERLEAD FLASH OR PROTRUSIONS.
- 4) LEAD COPLANARITY (BOTTOM OF LEADS AFTER FORMING) SHALL BE 0.004" INCHES MAX.
- 5) DRAWING CONFORMS TO JEDEC MS-012, VARIATION AB.
- 6) DRAWING IS NOT TO SCALE.

**NOTICE:** The information in this document is subject to change without notice. Users should warrant and guarantee that third party Intellectual Property rights are not infringed upon when integrating MPS products into any application. MPS will not assume any legal responsibility for any said applications.