

REVISIONS				
REV.	ECO. NO	DESCRIPTION	DATE	BY
E	3450	UPDATE 'M' PAD VIEW TO HAVE SQUARE CORNER, UPDATED ACCEPTS .062 PCB	2/28/2017	EP
F	4033	ADD 2M MOUNTING OPTION	4/18/2019	JH
H	4350	ADD S2837	4/7/2021	JH

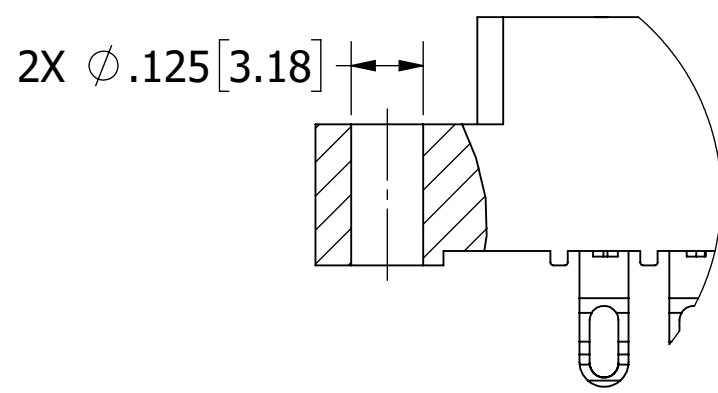
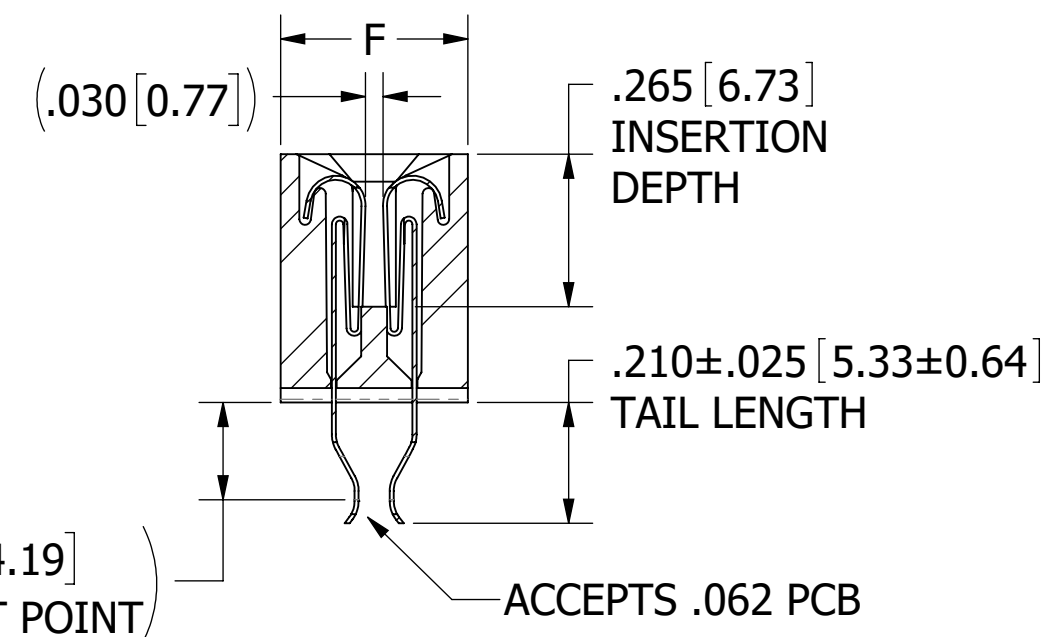
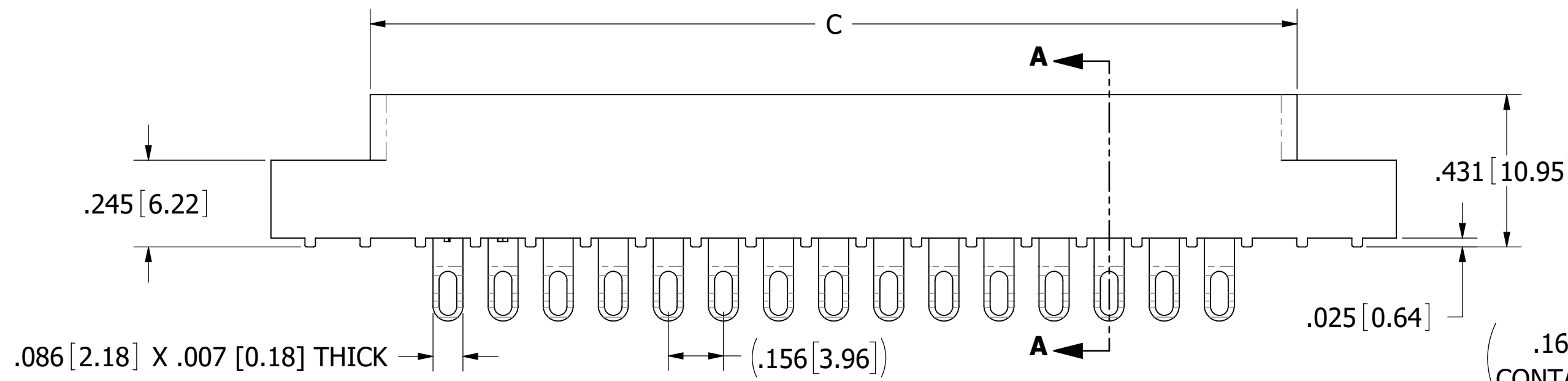
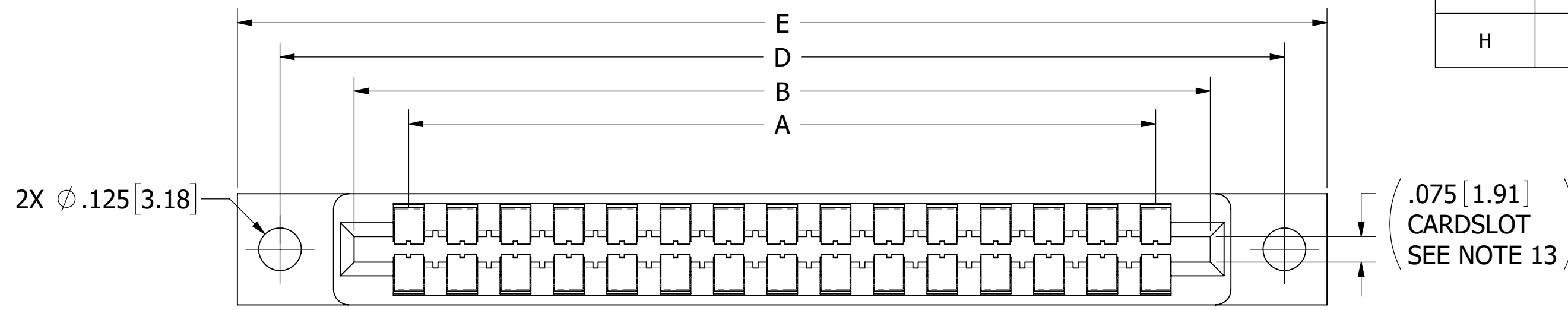

EMP _ _ 156- _ _ DPE-1(E) _ _ _

EMP _ _ 156- _ _ DPE-1(E) _ _ M

ADD 'M' TO END OF PART NUMBER FOR PADS ON ENDS OF CONNECTOR

CONTACT MARKINGS (LETTERS G, I, O & Q NOT USED)

SIZE 02 THRU 25
 1 2 3 ... 23 24 25
 A B C ... AA BB CC

SIZE 28 & 44
 1 2 3 ... 23 24 25
 A B C ... A B C

SIZE 36 & 43
 A B C ... A B C
 1 2 3 ... 23 24 25

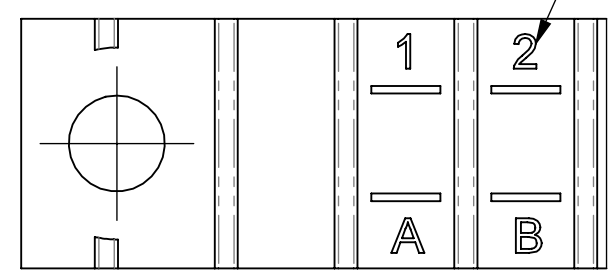

CONTACT ID

- NOTES:
- INSULATOR MATERIAL: SEE PART NUMBER CODING
 - CONTACT MATERIAL: SEE PART NUMBER CODING
 - PLATING: SEE PART NUMBER CODING
 - OPERATING TEMPERATURE: SEE PART NUMBER CODING
 - PROCESSING TEMP: SEE PART NUMBER CODING
 - UL FLAMMABILITY RATING: 94V-0
 - OPERATING VOLTAGE: 950 VAC
 - CURRENT RATING: 3 AMP
 - CONTACT RESISTANCE: 30 MILLI OHMS MAX
 - INSULATION RESISTANCE: 5000 MEGA OHMS
 - DURABILITY: 500 CYCLES MINIMUM
 - CONNECTOR IDENTIFICATION: THE PART SHALL BE MARKED WITH A PART NUMBER AND LOT CODE
 - BOARD THICKNESS ACCOMMODATED: .062 ± .008 [1.57 ± 0.20]
 - INSERTION FORCE: 16 OZ MAX PER CONTACT PAIR WHEN USING A .062 [1.57] TEST BLADE
 - INTERNAL INSPECTION TO BE PER SULLINS WORK INSTRUCTION WI-8.6-03
 - WITHDRAWAL FORCE: 1 OZ MIN PER CONTACT PAIR USING .062 [1.57] PCB
 - MODIFICATION: MICRO PLASTICS FLARED, CARD EXTENDER BEND FOR LOW PROFILE CONNECTOR, .055" INSIDE DIMENSION FOR .062" PCB. REVERSE CONTACT ID FOR 36 AND 43 POSITION

REF: _ _ M _ _ DSE _ -P13, P69, S1077, S1165, S2837

CUSTOMER COPY



UNLESS OTHERWISE SPECIFIED: DIMENSIONS ARE IN INCHES [MM]		DRAWN	DATE	NAME	
TOLERANCES: ANGULAR: ± 1° DECIMALS .XX = ± .02 [.5] .XXX = ± .005 [0.13] .XXXX = ± .0005 [0.013]		7/14/2009	JH	JH	
<small>THE INFORMATION HEREIN CONTAINS PROPRIETARY INFORMATION OF SULLINS ELECTRONICS AND IS NOT TO BE REPRODUCED, USED OR DISCLOSED TO OTHERS FOR ANY PURPOSE EXCEPT AS SPECIFICALLY AUTHORIZED IN WRITING BY AN OFFICER OF SULLINS ELECTRONICS.</small>					TITLE
					EDGE CARD, .156 CC, LP
					PART NUMBER
					EMP _ _ 156- _ _ DPE- _ _ (E) _ _ _
SIZE	CAGE CODE	DWG. NO.			REV
C	54453	C11270			H
SCALE: 3:1			SHEET 1 OF 3		

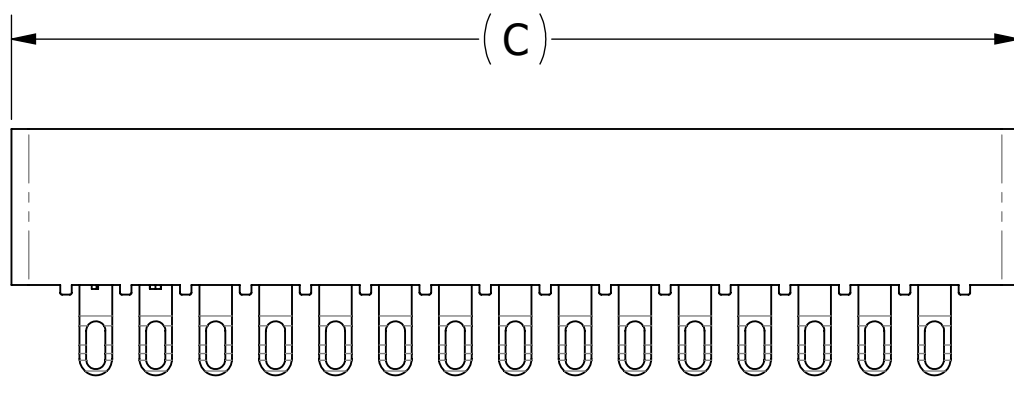
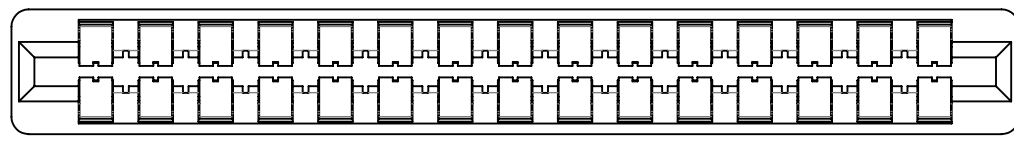

EMP -156- -DPE-4(E)

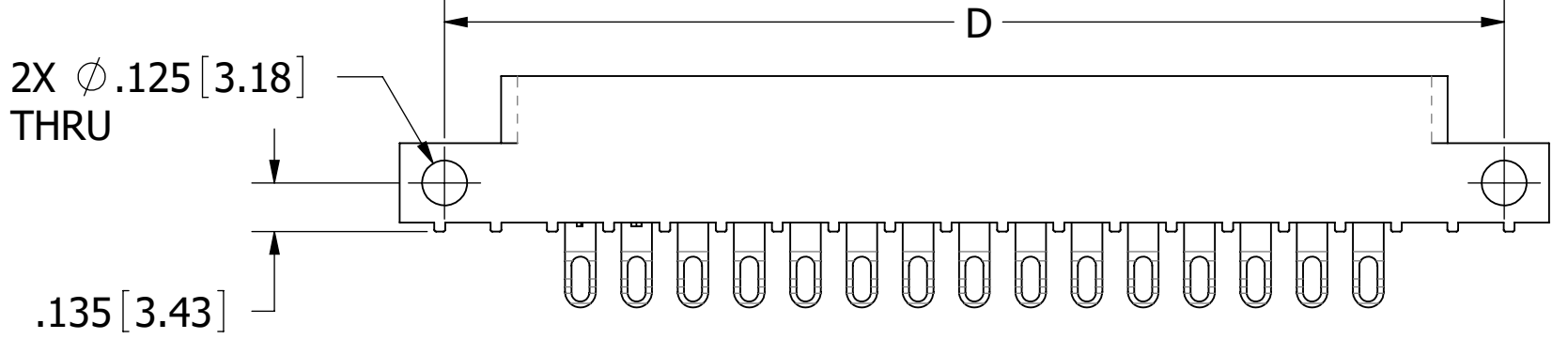
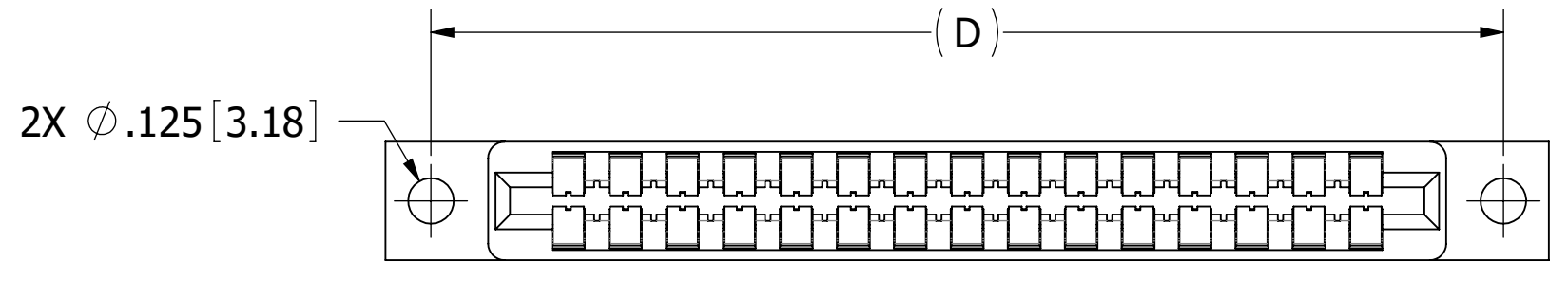

EMP -156- -DPE-8(E)

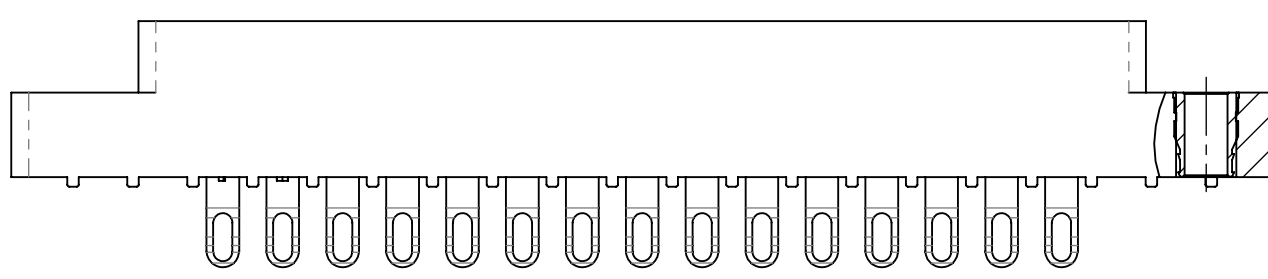
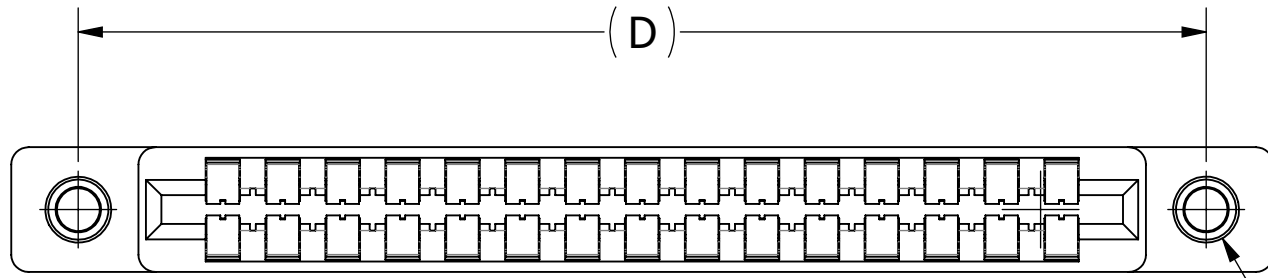

EMP -156- -DPE-2(E)

2X FLOATING BOBBIN
 Ø .116 [2.95] CLEARANCE
 HOLE FOR #4 SCREW

2X #4-40
 THREADED
 INSERTS

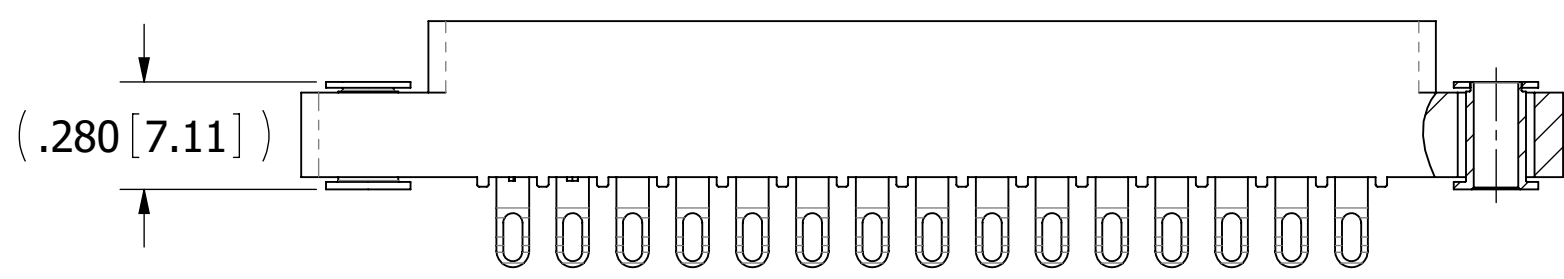
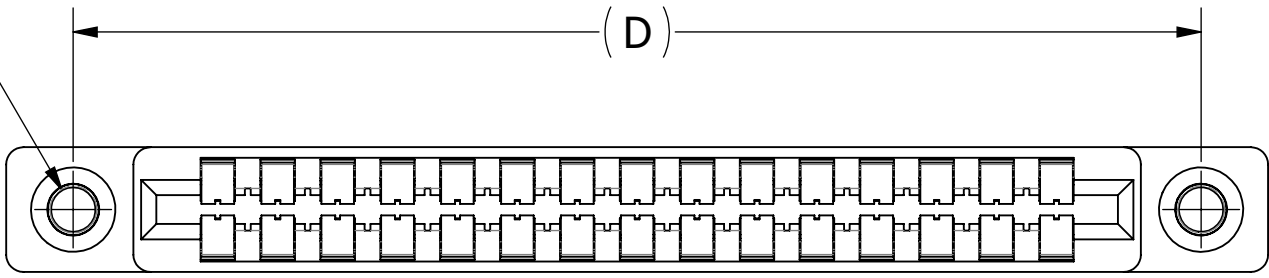

EMP -156- -DPE-3(E)

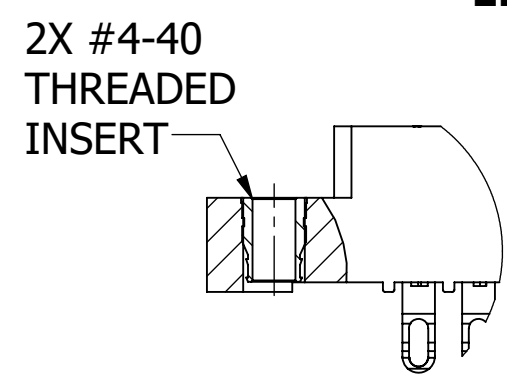

EMP -156- -DPE-2(E) -M

ADD 'M' TO END OF PART NUMBER
 FOR PADS ON ENDS OF CONNECTOR

CUSTOMER COPY



UNLESS OTHERWISE SPECIFIED: DIMENSIONS ARE IN INCHES [MM]	DRAWN	DATE	NAME	
		7/14/2009	JH	
TOLERANCES: ANGULAR: ± 1° DECIMALS .XX = ± .02 [.5] .XXX = ± .005 [.13] .XXXX = ± .0005 [.013]	THE INFORMATION HEREIN CONTAINS PROPRIETARY INFORMATION OF SULLINS ELECTRONICS AND IS NOT TO BE REPRODUCED, USED OR DISCLOSED TO OTHERS FOR ANY PURPOSE EXCEPT AS SPECIFICALLY AUTHORIZED IN WRITING BY AN OFFICER OF SULLINS ELECTRONICS.			TITLE
				EDGE CARD, .156 CC, LP
PART NUMBER				REV
EMP -156- -DPE- (E)				H
SIZE	CAGE CODE	DWG. NO.		
C	54453	C11270		
SCALE: 2:1		SHEET 2 OF 3		

PART NUMBER	NO. OF POS.	A ± .008[0.20]		B ± .008[0.20]		C ± .015[0.38]		D ± .010[0.25]		E ± .020[0.51]		E ± .020[0.51]		F + .005 [0.13]/-.015 [0.38]	
		IN	MM	IN	MM	IN	MM	IN	MM	IN	MM	IN	MM	IN	MM
		MOUNTING OPTION '4' ONLY													
EMP- 156-02-DPE- (E)	2	0.156	3.96	0.476	12.09	0.596	15.14								
EMP- 156-03-DPE- (E)	3	0.312	7.92	0.632	16.05	0.752	19.10								
EMP- 156-06-DPE- (E)	6	0.780	19.81	1.100	27.94	1.220	30.99	1.533	38.94	1.782	45.26	1.882	47.80		
EMP- 156-08-DPE- (E)	8	1.092	27.74	1.412	35.86	1.532	38.91	1.845	46.86	2.094	53.19	2.194	55.73		
EMP- 156-10-DPE- (E)	10	1.404	35.66	1.724	43.79	1.844	46.84	2.157	54.79	2.406	61.11	2.506	63.65		
EMP- 156-11-DPE- (E)	11	1.560	39.62	1.880	47.75	2.000	50.80	2.313	58.75	2.562	65.07	2.662	67.61		
EMP- 156-12-DPE- (E)	12	1.716	43.59	2.036	51.71	2.156	54.76	2.469	62.71	2.718	69.04	2.818	71.58	0.325	8.26
EMP- 156-15-DPE- (E)	15	2.184	55.47	2.504	63.60	2.624	66.65	2.937	74.60	3.186	80.92	3.286	83.46		
EMP- 156-18-DPE- (E)	18	2.652	67.36	2.972	75.49	3.092	78.54	3.405	86.49	3.654	92.81	3.754	95.35		
EMP- 156-22-DPE- (E)	22	3.276	83.21	3.596	91.34	3.716	94.39	4.029	102.34	4.278	108.66	4.378	111.20		
EMP- 156-24-DPE- (E)	24	3.588	91.14	3.908	99.26	4.028	102.31	4.341	110.26	4.590	116.59	4.690	119.13		
EMP- 156-25-DPE- (E)	25	3.744	95.10	4.064	103.23	4.184	106.27	4.497	114.22	4.746	120.55	4.846	123.09		
EMP- 156-28-DPE- (E)	28	4.212	106.98	4.532	115.11	4.652	118.16	4.965	126.11	5.214	132.44	5.314	134.98	0.438	11.13
EMP- 156-36-DPE- (E)	36	5.460	138.68	5.780	146.81	5.900	149.86	6.213	157.81	6.462	164.13	6.562	166.67		
EMP- 156-43-DPE- (E)	43	6.552	166.42	6.872	174.55	6.992	177.60	7.305	185.55	7.554	191.87	7.654	194.41	0.500	12.70
EMP- 156-44-DPE- (E)	44	6.708	170.38	7.028	178.51	7.148	181.56	7.461	189.51	7.710	195.83	7.810	198.37		

FOR CONNECTORS WITH THREADED INSERTS OR FLOATS

PART NUMBER CODING

EMP - 156 - DPE - (E)

- CONTACT MATERIAL**
 OMIT = PHOSPHOR BRONZE (SEE TABLE 2)
 Y = BERYLLIUM COPPER (SEE TABLE 3)
 OMIT WITH 'EMPP' PLATING CODE = SPINODAL (SEE TABLE 4)
- PLATING MODIFICATION CODE (SEE TABLE 1)**
- MODIFICATION CODE**
 E = OBSOLETE (CAN BE OMITTED)**
- MOUNTING STYLE**
 1 = .125" DIA. CLEARANCE HOLES
 2 = #4-40 THREADED INSERT
 3 = FLOATING BOBBIN
 4 = NO MOUNTING EARS
 8 = .125" DIA. SIDE HOLES
 1M = .125" DIA. CLEARANCE HOLES, PADS ON BOTH ENDS
 2M = #4-40 THREADED INSERT, PADS ON BOTH ENDS
- NUMBER OF POSITIONS (CONTACTS PER ROW)**
- INSULATOR MATERIAL**
 0 = PBT, BLUE
 2 = PBT, GREEN
 3 = PBT, BLACK
 4 = PA9T, BLACK
 1 = PPS, BROWN
 5 = PPS, BLACK
 6 = PPS, GREEN
 7 = PPS, BROWN
- PLATING (SEE TABLE 1)**

**OPTIONAL "E" CODE MEANS .020" LONGER CARD SLOT, NOW STANDARD, SEE DIMENSION 'B'

TABLE 1 (PLATING):

ALL PLATINGS HAVE .000050" MIN NICKEL UNDERPLATE

	CONTACT SURFACE	TERMINATION	PLATING MODIFICATION CODE
EMP, EMPP	.000010" GOLD OVERALL		OMIT
	.000030" GOLD	.000010" GOLD OVERALL	G
EMPSL	.000010" GOLD	.000100" PURE TIN, MATTE	K
	.000030" GOLD	.000100" PURE TIN, MATTE	GK
EMPL	.000100" PURE TIN, MATTE OVERALL		K

- EMPL AVAILABLE WITH PHOSPHOR BRONZE CONTACTS ONLY
- EMP, EMPSL AVAILABLE IN PHOSPHOR BRONZE OR BERYLLIUM COPPER
- EMPP = SPINODAL

TABLE 2 (PHOSPHOR BRONZE CONTACTS): EMP, EMPL, EMPSL

INSULATOR MATERIAL CODE	OPERATING TEMPERATURE	PROCESSING TEMPERATURE
0, 2, 3	-65°C TO +125°C	WAVE/MANUAL SOLDERING ONLY
1, 5, 6, 7	-65°C TO +125°C	260°C MAX FOR 20 SEC
4	-65°C TO +125°C	260°C MAX FOR 20 SEC

TABLE 3 (BERYLLIUM COPPER CONTACTS): EMP OR EMPSL WITH 'Y' MODIFICATION CODE

INSULATOR MATERIAL CODE	OPERATING TEMPERATURE	PROCESSING TEMPERATURE
0, 2, 3	-65°C TO +125°C	WAVE /MANUAL SOLDERING ONLY
1, 5, 6, 7	-65°C TO +150°C	260°C MAX FOR 20 SEC
4	-65°C TO +150°C	260°C MAX FOR 20 SEC

TABLE 4 (SPINODAL CONTACTS): EMPP

INSULATOR MATERIAL CODE	OPERATING TEMPERATURE	PROCESSING TEMPERATURE
1, 5, 6, 7	-65°C TO +200°C	260°C MAX FOR 20 SEC

CUSTOMER COPY

UNLESS OTHERWISE SPECIFIED: DIMENSIONS ARE IN INCHES [MM]	DRAWN	DATE	NAME	
		7/14/2009	JH	
TOLERANCES: ANGULAR: ± 1° DECIMALS .XX = ± .02 [.5] .XXX = ± .005 [.13] .XXXX = ± .0005 [.013]	THE INFORMATION HEREIN CONTAINS PROPRIETARY INFORMATION OF SULLINS ELECTRONICS AND IS NOT TO BE REPRODUCED, USED OR DISCLOSED TO OTHERS FOR ANY PURPOSE EXCEPT AS SPECIFICALLY AUTHORIZED IN WRITING BY AN OFFICER OF SULLINS ELECTRONICS.			TITLE
				EDGE CARD, .156 CC, LP
PART NUMBER				REV
EMP - 156 - DPE - (E)				H
SIZE	CAGE CODE	DWG. NO.		
C	54453	C11270		
SCALE: 2:1		SHEET 3 OF 3		

