

PANEL HOLE DIMENSION

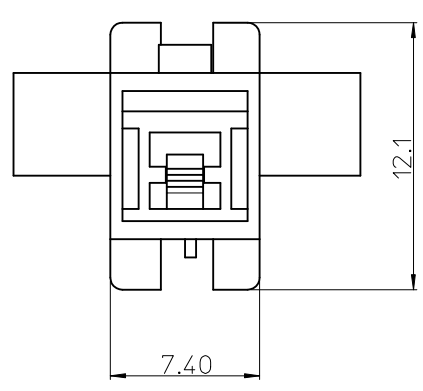
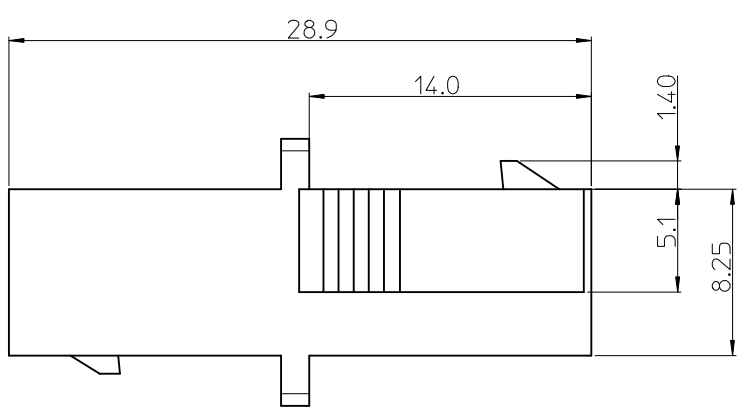

NOTES.

- MATERIAL & COLOR :
 35150-0110 : NATURAL, PBT, UNFILLED, UL94V-0
 35150-0119 : NATURAL, PC/PET, UNFILLED, UL94V-0
- MATED HOUSING : 35151-0110
- APPLICABLE TERMINAL : 35745-0*10
- APPLICABLE TPA : 35182-019*

NEW RELEASE EC NO: KOR2011-0016 DRWN: JHPARK01 2010/08/06 CHKD: SHCHU 2010/08/06 APPR: YUNSIKKIM 2010/08/06	QUALITY SYMBOLS	GENERAL TOLERANCES (UNLESS SPECIFIED)	DIMENSION STYLE	SCALE	DESIGN UNITS	THIRD ANGLE PROJECTION																									
	$\nabla=0$ $\square=0$	<table border="1"> <thead> <tr> <th></th> <th>mm</th> <th>INCH</th> </tr> </thead> <tbody> <tr> <td>4 PLACES</td> <td>± ---</td> <td>± ---</td> </tr> <tr> <td>3 PLACES</td> <td>± ---</td> <td>± ---</td> </tr> <tr> <td>2 PLACES</td> <td>± ---</td> <td>± ---</td> </tr> <tr> <td>1 PLACE</td> <td>± 0.3</td> <td>± ---</td> </tr> </tbody> </table>		mm	INCH	4 PLACES	± ---	± ---	3 PLACES	± ---	± ---	2 PLACES	± ---	± ---	1 PLACE	± 0.3	± ---	MM ONLY	4/1	METRIC											
		mm	INCH																												
	4 PLACES	± ---	± ---																												
3 PLACES	± ---	± ---																													
2 PLACES	± ---	± ---																													
1 PLACE	± 0.3	± ---																													
DESCRIPTION	<table border="1"> <thead> <tr> <th>REV</th> <th>DESCRIPTION</th> </tr> </thead> <tbody> <tr> <td>A</td> <td></td> </tr> </tbody> </table>	REV	DESCRIPTION	A		<table border="1"> <thead> <tr> <th>DRAWN BY</th> <th>DATE</th> <th>TITLE</th> </tr> </thead> <tbody> <tr> <td>WY. YANG</td> <td></td> <td>070 W/W RECEPTACLE HSG-1P</td> </tr> <tr> <th>CHECKED BY</th> <th>DATE</th> <td></td> </tr> <tr> <td>BK. CHOI</td> <td></td> <td></td> </tr> <tr> <th>APPROVED BY</th> <th>DATE</th> <td></td> </tr> <tr> <td>CW. LEE</td> <td></td> <td></td> </tr> </tbody> </table>	DRAWN BY	DATE	TITLE	WY. YANG		070 W/W RECEPTACLE HSG-1P	CHECKED BY	DATE		BK. CHOI			APPROVED BY	DATE		CW. LEE			<table border="1"> <thead> <tr> <th>MATERIAL NO.</th> <th>DOCUMENT NO.</th> <th>SHEET NO.</th> </tr> </thead> <tbody> <tr> <td>SEE NOTE</td> <td>SD-35150-0110</td> <td>1 OF 1</td> </tr> </tbody> </table>	MATERIAL NO.	DOCUMENT NO.	SHEET NO.	SEE NOTE	SD-35150-0110	1 OF 1
REV	DESCRIPTION																														
A																															
DRAWN BY	DATE	TITLE																													
WY. YANG		070 W/W RECEPTACLE HSG-1P																													
CHECKED BY	DATE																														
BK. CHOI																															
APPROVED BY	DATE																														
CW. LEE																															
MATERIAL NO.	DOCUMENT NO.	SHEET NO.																													
SEE NOTE	SD-35150-0110	1 OF 1																													
	DRAFT WHERE APPLICABLE MUST REMAIN WITHIN DIMENSIONS	<table border="1"> <thead> <tr> <th>SIZE</th> <th>THIS DRAWING CONTAINS INFORMATION THAT IS PROPRIETARY TO MOLEX INCORPORATED AND SHOULD NOT BE USED WITHOUT WRITTEN PERMISSION</th> </tr> </thead> <tbody> <tr> <td>A3</td> <td></td> </tr> </tbody> </table>	SIZE	THIS DRAWING CONTAINS INFORMATION THAT IS PROPRIETARY TO MOLEX INCORPORATED AND SHOULD NOT BE USED WITHOUT WRITTEN PERMISSION	A3																										
SIZE	THIS DRAWING CONTAINS INFORMATION THAT IS PROPRIETARY TO MOLEX INCORPORATED AND SHOULD NOT BE USED WITHOUT WRITTEN PERMISSION																														
A3																															