

Features

- 80C51 Compatible
 - Two I/O Ports
 - Two 16-bit Timer/Counters
 - 256 bytes RAM
- 4 Kbytes ROM or 4 Kbytes Flash Program Memory
- 256 bytes EEPROM (Stack Die Packaging Technology on SO20 Package)
- X2 Speed Improvement Capability (6 Clocks/Machine Cycle)
- 10-bit, 6 Channels A/D Converter
 - One-channel with Programmable Gain and Rectifying Amplifier (Accuracy +/- 5%)
 - Voltage Reference for A/D & External Analog
- Hardware Watchdog Timer
- Programmable I/O Mode: Standard C51, Input Only, Push-pull, Open Drain
- Asynchronous Port Reset
- Triple System Clock
 - Crystal or Ceramic Oscillator (24 MHz)
 - RC Oscillator (12 MHz), with Calibration Factor Using External R and C (Accuracy +/- 3.5% with Ideal R and C)
 - RC Oscillator, Low Power Consumption (12 MHz Low Accuracy)
 - Programmable Prescaler
- One PWM Unit Block With:
 - 16-bits Programmable Counter
 - 3 Independent Modules
- One PWM Unit Block with:
 - 16 bits Programmable Counter
 - 1 Module
- Interrupt Structure With:
 - 7 Interrupt Sources,
 - 4 interrupt Priority Levels
- Power Control Modes:
 - Idle Mode
 - Power-down Mode
 - Power Fail Detect, Power On Reset
 - Quiet mode for A to D Conversion
- Power Supply: 3 to 3.6V
- Temperature Range: -40 to 85° C
- Package: SO20, SO24 (upon request)

Description

The AT8xEB5114 is a high performance version of the 80C51 8-bit microcontroller in a Low Pin Count package.

The AT8xEB5114 retains all the features of the standard 80C51 with 4 Kbytes program memory, 256 bytes of internal RAM, a 7-source, 4-level interrupt system, an on-chip oscillator and two timers/counters. AT8xEB5114 may include a serial two wire interface EEPROM housed together with the microcontroller die in the same package.

The AT8xEB5114 is dedicated for analog interfacing applications. For this, it has a 10-bit, 6 channels A/D converter and two PWM units; these PWM blocks provide PWM generation with variable frequency and pulse width.

In addition, the AT8xEB5114 has a Hardware Watchdog Timer and an X2 speed improvement mechanism. The X2 feature allows to keep the same CPU power at a divided by two oscillator frequency. The prescaler allows to decrease CPU and peripherals clock frequency. The fully static design of the AT8xEB5114 allows to reduce system power consumption by bringing the clock frequency down to any value, even DC, without loss of data.



**Low-pin-count
8-bit
microcontroller
with A/D
converter**

**AT83EB5114
AT89EB5114**

Rev. 4311C-8051-02/08



The AT8xEB5114 has 3 software-selectable modes of reduced activity for further reduction in power consumption. In idle mode the CPU is frozen while the peripherals are still operating. In quiet mode, only the A/D converter is operating. In power-down mode the RAM is saved and all other functions are inoperative. Three oscillator sources, crystal, precision RC and low power RC, provide versatile power management.

The AT8xEB5114 is available in low pin count packages (ROM and flash versions).

Figure 1. Block Diagram

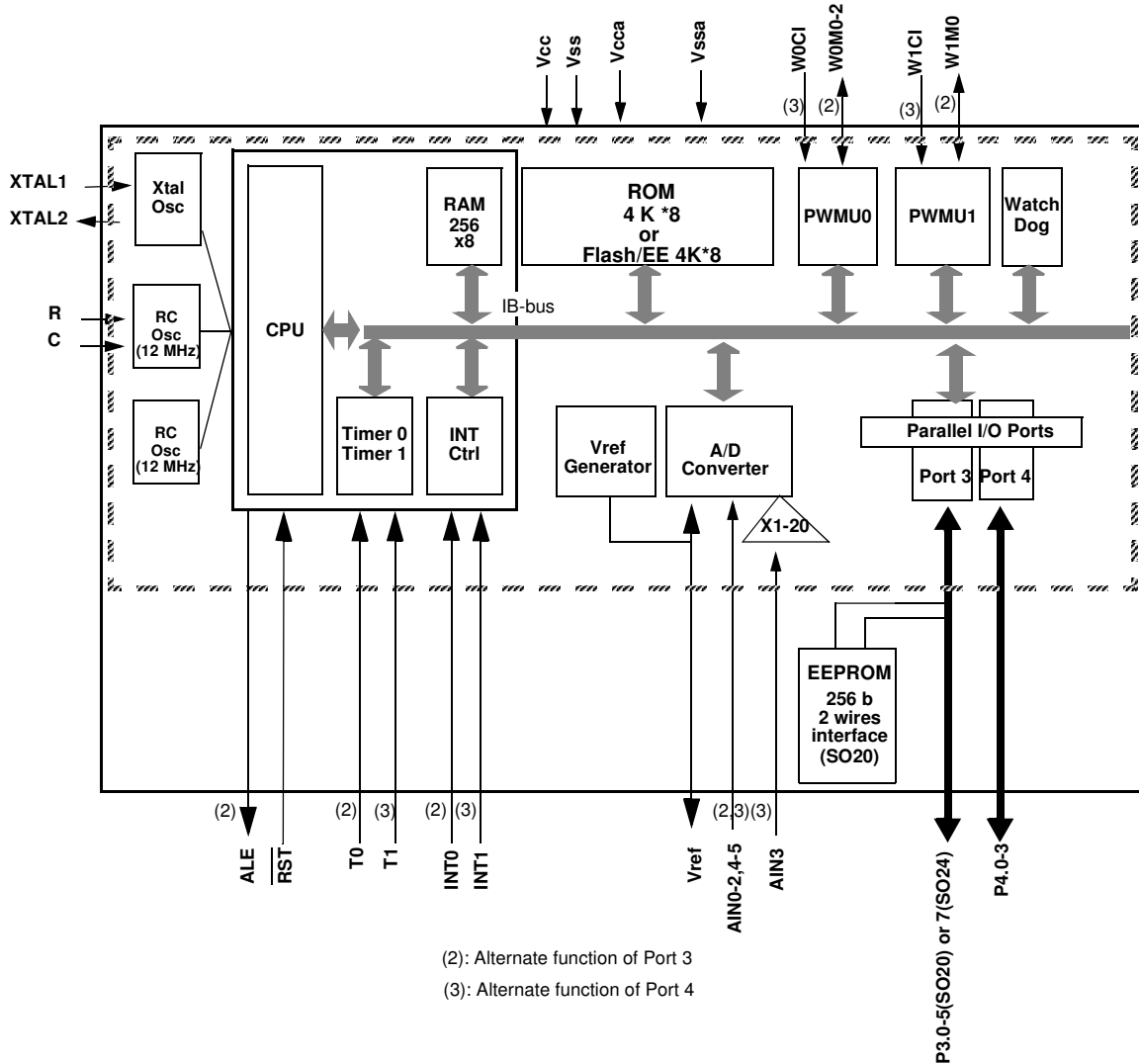

Pin Configuration

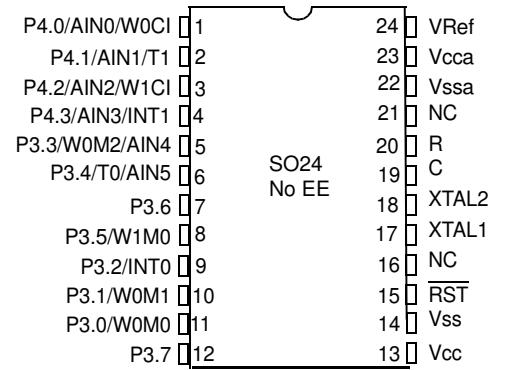
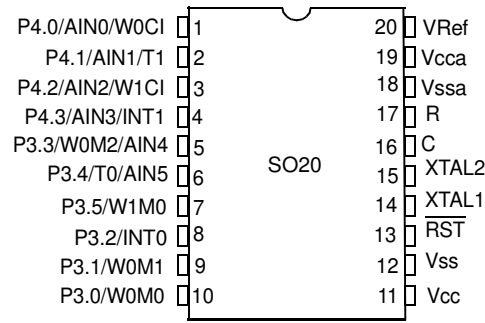



Pin Description

SO20	SO24	Mnemonic	Type	Name and Function
12	14	V _{SS}	Power	Ground: 0V reference
18	22	V _{SSA}	Power	Analog Ground: 0V reference for analog part
11	13	V _{CC}	Power	Power Supply: This is the power supply voltage for normal, idle and power-down operation.
19	23	V _{CCA}	Power	Analog Power Supply: This is the power supply voltage for analog part This pin must be connected to power supply.
20	24	VREF	Analog	VREF: A/D converter positive reference input, output of the internal voltage reference
14	17	XTAL1	I	Input to the inverting oscillator amplifier and input to the internal clock generator circuit
15	18	XTAL2	O	Output from the inverting oscillator amplifier. This pin can't be connected to the ground.
17	20	R	Analog	Resistor Input for the precision RC oscillator
16	19	C	Analog	Capacitor Input for the precision RC oscillator
13	15	$\overline{\text{RST}}$	I/O	Reset input with integrated pull-up A low level on this pin for two machine cycles while the oscillator is running, resets the device.
		P3.0-P3.7	I/O	Port 3: Port 3 is an 8-bit programmable I/O port with internal pull-ups. See "Port Types" on page 32. for a description of I/O ports. Port 3 also serves the special features of the 80C51 family, as listed below.
10	11		I/O	W0M0 (P3.0): External I/O for PWMU 0 module 0
9	10		I/O	W0M1 (P3.1): External I/O for PWMU 0 module 1
8	9		I/O	$\overline{\text{INT0}}$ (P3.2): External interrupt 0
5	5		I/O	W0M2 / AIN4 (P3.3): External I/O for PWMU 0 module 2. P3.3 is also an input of the analog to digital converter.
6	6		I/O	T0 / AIN5(P3.4): Timer 0 external input. P3.4 is also an input of the analog to digital converter.
7	8		I/O	W1M0 (P3.5): External I/O for PWMU 1 module 0, can also be used to output the external clocking signal
		P4.0-P4.3	I/O	Port 4: Port 4 is an 4-bit programmable I/O port with internal pull-ups. See "Port Types" on page 32. for a description of I/O ports. Port 4 is also the input port of the Analog to digital converter
1	1		I/O	AIN0 (P4.0): A/D converter input 0 W0CI: Count input of PWMU0
2	2		I/O	AIN1 (P4.1): A/D converter input 1 T1: Timer 1 external input
3	3		I/O	AIN2 (P4.2): A/D converter input 2 W1CI: Count input of PWMU1
4	4		I/O	AIN3 (P4.3): A/D converter input 3, programmable gain INT1: External interrupt 1

SFR Mapping

The Special Function Registers (SFRs) of the AT8xEB5114 belong to the following categories:

- C51 core registers: ACC, AUXR, AUXR1, B, DPH, DPL, PSW, SP, FCON, HSB
- I/O port registers: P3, P4, P3M1, P3M2, P4M1
- Timer registers: TCON, TH0, TH1, TL0, TL1, TMOD
- Power and clock control registers: CKCON, CKRL, CKSEL, OSCBFA, OSCCON, PCON
- Interrupt system registers: IEN0, IPH0, IPL0, IOR
- WatchDog Timer: WDTRST, WDTPRG
- PWM0 registers: W0CH, W0CL, W0CON, W0FH, W0FL, W0IC, W0MOD, W0R0H, W0R0L, W0R1H, W0R1L, W0R2H, W0R2L
- PWM1 registers: W1CH, W1CL, W1CON, W1FH, W1FL, W1IC, W1R0H, W1R0L
- ADC registers: ADCA, ADCF, ADCLK, ADCON, ADDH, ADDL

Table 1. SFR Addresses and Reset Values

	0/8	1/9	2/A	3/B	4/C	5/D	6/E	7/F	
F8h	W1CON XXX0 0000		W1FH 0000 0000	W1FL 0000 0000	W1CH 0000 0000	W1CL 0000 0000	W1C 0000 0000		FFh
F0h	B 0000 0000		ADCLK 0000 0000	ADCON 0000 0000	ADDL XXXXXX00	ADDH 0000 0000	ADCF 0000 0000	ADCA 0000 0000	F7h
E8h	W0CON 00XX 0000	W0MOD 00XX X000	W0FH 0000 0000	W0FL 0000 0000	W0CH 0000 0000	W0CL 0000 0000	W0IC 0000 0000	HSB 1111 XX11	EFh
E0h	ACC 0000 0000				P3M2 0000 0000				E7h
D8h		W0R0H 0000 0000	W0R0L 0000 0000	W0R1H 0000 0000	W0R1L 0000 0000	W0R2H 0000 0000	W0R2L 0000 0000		DFh
D0h	PSW 0000 0000	FCON 1111 1111				P3M1 0000 0000	P4M1 0000 0000		D7h
C8h		W1R0H 0000 0000	W1R0L 0000 0000						CFh
C0h	P4 XXXX 1111								C7h
B8h	IPL0 X000 0000								BFh
B0h	P3 1111 1111							IPH0 X000 0000	B7h
A8h	IEN0 0000 0000								AFh
A0h			AUXR1 XXXX 0XX0			IOR XXXXXX00	WDTRST XXXXXXXX	WDTPRG XXXX X000	A7h
98h								OSCBFA 0111 0110	9Fh
90h								CKRL XXXX 1000	97h
88h	TCON 0000 0000	TMOD 0000 0000	TL0 0000 0000	TL1 0000 0000	TH0 0000 0000	TH1 0000 0000	AUXR 0XX0 XXX0	CKCON XXXX XXX0	8Fh
80h		SP 0000 0111	DPL 0000 0000	DPH 0000 0000		CKSEL XXXX XXCC	OSCCON XXXX XXCC	PCON 00XX XX00	87h
	0/8	1/9	2/A	3/B	4/C	5/D	6/E	7/F	

Note: 1. "C", value defined by the Hardware Security Byte, see Table 2 on page 15

Mnemonic	Add	Name	7	6	5	4	3	2	1	0
ACC	E0h	Accumulator								
ADCA	F7h	ADC Amplifier Configuration	-	-	-	-	-	AC3E	AC3G1	AC3G0
ADCF	F6h	ADCF Register	-	-	CH5	CH4	CH3	CH2	CH1	CH0
ADCLK	F2h	ADC Clock Prescaler	SELREF	PRS6	PRS5	PRS4	PRS3	PRS2	PRS1	PRS0
ADCON	F3h	ADC Control Register	QUIETM	PSIDLE	ADEN	ADEOC	ADSST	SCH2	SCH1	SCH0
ADDH	F5h	ADC Data High Byte Register	ADAT9	ADAT8	ADAT7	ADAT6	ADAT5	ADAT4	ADAT3	ADAT2
ADDL	F4h	ADC Data Low Byte Register	-	-	-	-	-	-	ADAT1	ADAT0
AUXR	8Eh	Auxiliary Register	DPU	-	-	LOWVD	-	-	-	-
AUXR1	A2h	Auxiliary Register 1	-	-	-	-	-	-	-	DPS
B	F0h	B Register								
CKCON	8Fh	Clock control Register	-	-	-	-	-	-	-	X2
CKRL	97h	Clock Prescaler Register	-	-	-	-	CKRL3	CKRL2	CKRL1	CKRL0
CKSEL	85h	Clock Selection register	-	-	-	-	-	-	CKS1	CKS0
DPH	83h	Data pointer High Byte								
DPL	82h	Data pointer Low Byte								
FCON	D1h	Auxiliary Register	FPL3	FPL2	FPL1	FPL0	FPS	FMOD1	FMOD0	FBUSY
HSB	EFh	Hardware Security Byte	X2	RST_OSC1	RST_OSC0	RST_OCLK	-	-	LB1	LB0
IEN0	A8h	Interrupt Enable Register	EA	EADC	EW1	EW0	ET1	EX1	ET0	EX0
IOR	A5h	Interrupt Option Register	-	-	-	-	-	-	ESB1	ESB0
IPH0	B7h	Interrupt Priority register	-	PADCH	PW1H	PW0H	PT1H	PX1H	PT0H	PX0H
IPL0	B8h	Interrupt Priority Register	-	PADC	PW1	PW0	PT1	PX1	PT0	PX0
OSCBFA	9Fh	Oscillator B Frequency Adjust	OSCBFA7	OSCBFA6	OSCBFA5	OSCBFA4	OSCBFA3	OSCBFA2	OSCBFA1	OSCBFA0
OSCCON	86h	Clock Control Register	-	-	-	OSCBRY	LCKEN	OSCCEN	OSCBEN	OSCAEN
P3	B0h	Port 3 Register								
P3M1	D5h	Port 3 Output Configuration	P3M1.7	P3M1.6	P3M1.5	P3M1.4	P3M1.3	P3M1.2	P3M1.1	P3M1.0
P3M2	E4h	Port 3 Output Configuration	P3M2.7	P3M2.6	P3M2.5	P3M2.4	P3M2.3	P3M2.2	P3M2.1	P3M2.0
P4	C0h	Port 4 register								
P4M1	D6h	Port 4 Output Configuration	P4M1.7	P4M1.6	P4M1.5	P4M1.4	P4M1.3	P4M1.2	P4M1.1	P4M1.0
PCON	87h	Power Modes Control Register	SMOD1	SMOD0	-	-	GF1	GF0	PD	IDL
PSW	D0h	Program Status Word	CY	AC	F0	RS1	RS0	OV	F1	P
SP	81h	Stack pointer								
TCON	88h	Timer/Counter Control Register	TF1	TR1	TF0	TR0	IE1	IT1	IE0	IT0
TH0	8Ch	Timer 0 High Byte Registers	TH0.7	TH0.6	TH0.5	TH0.4	TH0.3	TH0.2	TH0.1	TH0.0
TH1	8Dh	Timer 1 High Byte Registers	TH1.7	TH1.6	TH1.5	TH1.4	TH1.3	TH1.2	TH1.1	TH1.0
TL0	8Ah	Timer 0 Low Byte Registers	TL0.7	TL0.6	TL0.5	TL0.4	TL0.3	TL0.2	TL0.1	TL0.0
TL1	8Bh	Timer 1 Low Byte Registers	TL1.7	TL1.6	TL1.5	TL1.4	TL1.3	TL1.2	TL1.1	TL1.0



Mnemonic	Add	Name	7	6	5	4	3	2	1	0
TMOD	89h	Timer/Counter Mode Register	GATE1	C/T1#	M11	M01	GATE0	C/T0#	M10	M00
W0CH	ECh	PWMU0 Counter High Control	W0C15	W0C14	W0C13	W0C12	W0C11	W0C10	W0C9	W0C8
W0CL	EDh	PWMU0 Counter Low Control	W0C7	W0C6	W0C5	W0C4	W0C3	W0C2	W0C1	W0C0
W0CON	E8h	PWMU0 Control Register	W0UP	W0R	-	-	W0OS	W0EN2	W0EN1	W0EN0
W0FH	EAh	PWMU0 Frequency High Control	W0F15	W0F14	W0F13	W0F12	W0F11	W0F10	W0F9	W0F8
W0FL	EBh	PWMU0 Frequency Low Control	W0F7	W0F6	W0F5	W0F4	W0F3	W0F2	W0F1	W0F0
W0IC	EEh	PWMU0 Interrupt Configuration	W0CF	W0CF2	W0CF2	W0CF0	W0ECF	W0ECF2	W0ECF1	W0ECF0
W0MOD	E9h	PWMU0 Counter Mode Register	W0CPS1	W0CPS0	-	-	-	W0INV2	W0INV1	W0INV0
W0R0H	D9h	PWMU0 Module 0 High Toggle	W0R0H15	W0R0H14	W0R0H13	W0R0H12	W0R0H11	W0R0H10	W0R0H9	W0R0H8
W0R0L	DAh	PWMU0 Module 0 Low Toggle	W0R0H7	W0R0H6	W0R0H5	W0R0H4	W0R0H3	W0R0H2	W0R0H1	W0R0H0
W0R1H	DBh	PWMU0 Module 1 High Toggle	W0R1H15	W0R1H14	W0R1H13	W0R1H12	W0R1H11	W0R1H10	W0R1H9	W0R1H8
W0R1L	DCh	PWMU0 Module1 Low Toggle	W0R1H7	W0R1H6	W0R1H5	W0R1H4	W0R1H3	W0R1H2	W0R1H1	W0R1H0
W0R2H	DDh	PWMU0 Module 2 High Toggle	W0R2H15	W0R2H14	W0R2H13	W0R2H12	W0R2H11	W0R2H10	W0R2H9	W0R2H8
W0R2L	DEh	PWMU0 Module 2 Low Toggle	W0R2H7	W0R2H6	W0R2H5	W0R2H4	W0R2H3	W0R2H2	W0R2H1	W0R2H0
W1CH	FCh	PWMU1 Counter High Control	W1C15	W1C14	W1C13	W1C12	W1C11	W1C10	W1C9	W1C8
W1CL	FDh	PWMU1 Counter Low Control	W1C7	W1C6	W1C5	W1C4	W1C3	W1C2	W1C1	W1C0
W1CON	F8h	PWMU1 Control Register	W1UP	W1R	-	W1OCLK	W1CPS1	W1CPS0	W1INV0	W1EN0
W1FH	FAh	PWMU1 Frequency High Control	W1F15	W1F14	W1F13	W1F12	W1F11	W1F10	W1F9	W1F8
W1FL	FBh	PWMU1 Frequency Low Control	W1F7	W1F6	W1F5	W1F4	W1F3	W1F2	W1F1	W1F0
W1IC	FEh	PWMU1 Interrupt Configuration	W1CF	-	-	W1CF0	W1ECOF	-	-	W0ECF0
W1R0H	C9h	PWMU1 Module 0 High Toggle	W1R0H15	W1R0H14	W1R0H13	W1R0H12	W1R0H11	W1R0H10	W1R0H9	W1R0H8
W1R0L	CAh	PWMU1 Module 0 Low Toggle	W1R0H7	W1R0H6	W1R0H5	W1R0H4	W1R0H3	W1R0H2	W1R0H1	W1R0H0
WDTRST	A6h	Watchdog Timer enable Register								
WDTPRG	A7h	WatchDog Timer Duration Prg	-	-	-	-	-	S2	S1	S0

Power Monitor

The Power Monitor function supervises the evolution of the voltages feeding the microcontroller, and if needed, suspends its activity when the detected value is out of specification.

It warrants proper startup when AT8xEB5114 is powered up and prevents code execution errors when the power supply becomes lower than the functional threshold.

This chapter describes the functions of the power monitor.

Description

In order to startup and to properly maintain the microcontroller operation, Vcc has to be stabilized in the Vcc operating range and the oscillator has to be stabilized with a nominal amplitude compatible with logic threshold.

In order to be sure the oscillator is stabilized, there is an internal counter which maintains the reset during 1024 clock periods in case the oscillator selected is the OSC A and 64 clock periods in case the oscillator used is OSC B or OSC C.

This control is carried out during three phases: the power-up, normal operation and stop. In accordance with the following requirements:

- it guarantees an operational Reset when the microcontroller is powered-up, and
- a protection if the power supply goes below minimum operating Vcc

Figure 2. Power Monitor Block Diagram

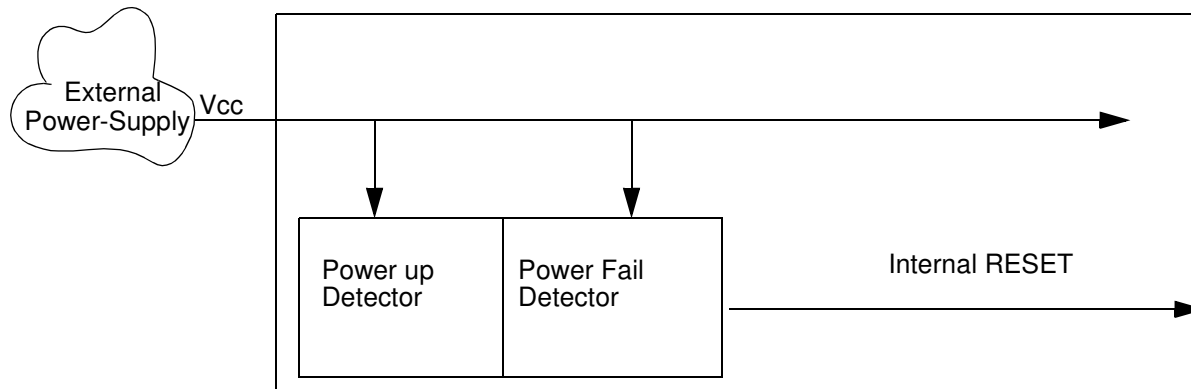

Power Monitor diagram

The Power Monitor monitors the power-supply in order to detect any voltage drops which are not in the target specification. The power monitor block verifies two kinds of situation that may occur:

- during the power-up condition, when Vcc reaches the product specification,
- during a steady-state condition, when Vcc is at nominal value but disturbed by any undesired voltage drops.

Figure 2 shows some configurations which can be handled by the Power Monitor.

Figure 3. Power-Up and Steady-state Conditions Monitored

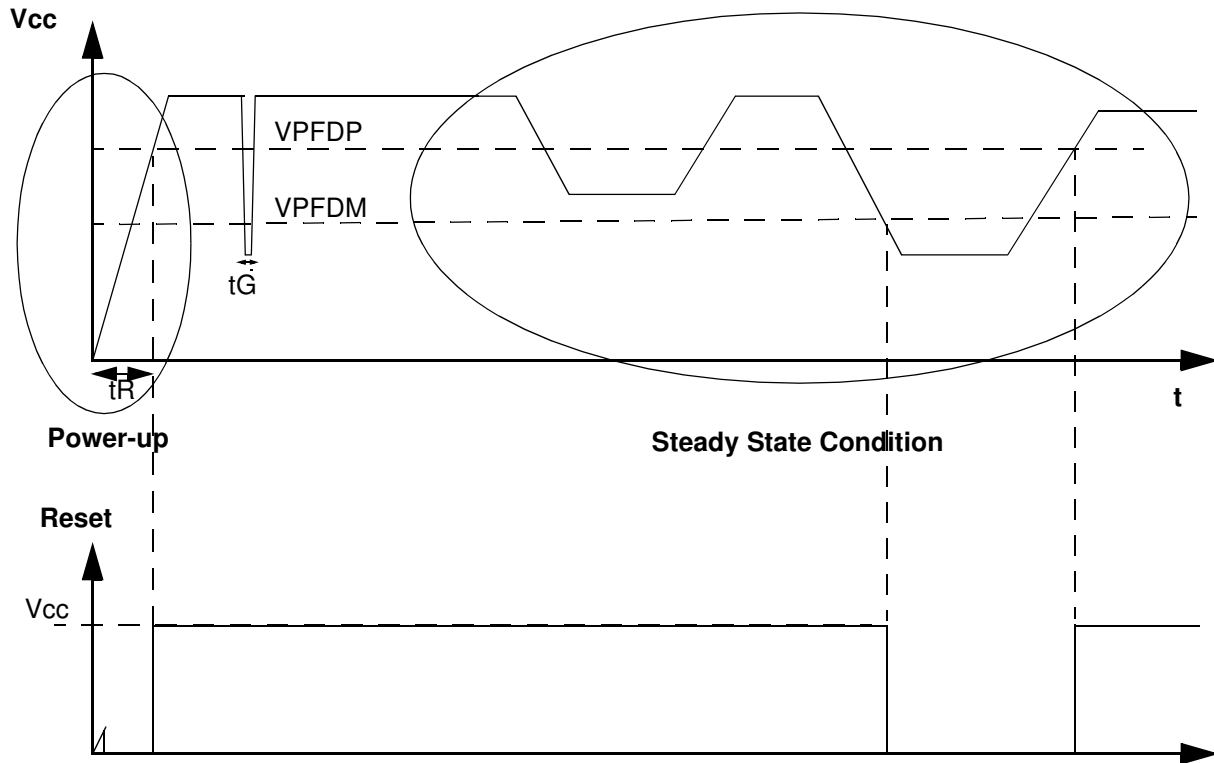

The POR/PFD forces the CPU into reset mode when VCC reaches a voltage condition which is out of specification.

The thresholds and their functions are:

- VPFDP: the Vcc has reached a minimum functional value at power-up. The circuit leaves the RESET mode
- VPFDM: the Vcc has reached a low threshold functional value for the microcontroller. An internal RESET is set.

Glitch filtering prevents the system from RESET when short duration glitches are carried on Vcc power-supply (See “Electrical Characteristics” on page 84.).

In case Vcc is below VPFDP, LOWVD bit in AUXR (See Table 12 on page 23) is cleared by hardware. This bit allows the user to know if the voltage is below VPFDP.

Note: For proper reset operation V_{CCA} and V_{CC} must be considered together (same power source). However, to improve the noise immunity, it is better to have two decoupling networks close to power pins (one for V_{CCA}/V_{SSA} pair and one for V_{CC}/V_{SS} pair).

Clock System

Overview

The AT8xEB5114 oscillator system provides a reliable clocking system with full mastering of speed versus CPU power trade-off. Several clock sources are possible:

- External clock input
- High speed crystal or ceramic oscillator
- Integrated accurate oscillator with external R and C.
- Low power consumption Integrated RC oscillator without external components.

The AT8xEB5114 needs 6 clock periods per machine cycle when the X2 function is set. However, the selected clock source can be divided by 2-32 before clocking the CPU and the peripherals.

By default, the active oscillator after reset is the high speed crystal/ceramic oscillator. Any two bits in a hardware configuration byte programmed by a Flash programmer or by metal mask can activate any other one.

The clock system is controlled by several SFR registers: CKCON, CKSEL, CKRL, OSCON, PCON and HSB which is the hardware security byte.

Blocks Description

The AT8xEB5114 includes three oscillators:

- Crystal oscillator optimized for 24 MHz.
- 1 accurate oscillator with a typical frequency of 12 MHz.
- 1 low power oscillator with a typical frequency of 14 MHz.

Figure 4. Functional Block Diagram

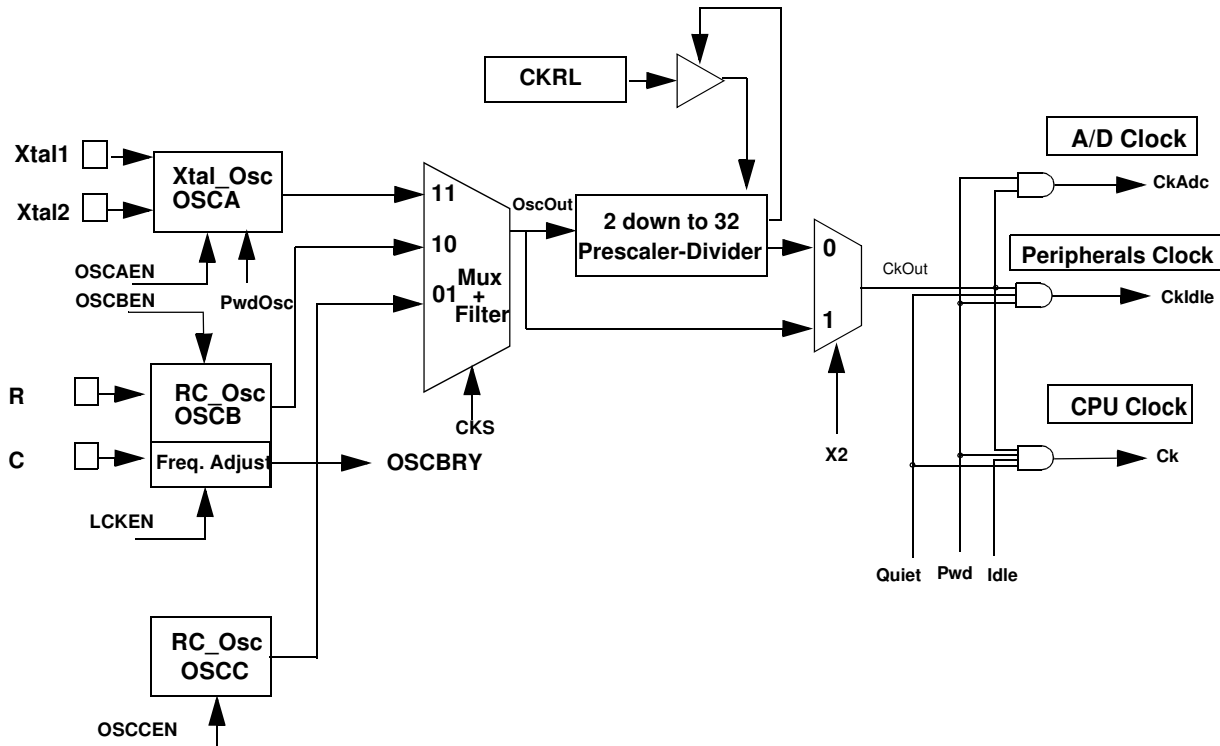

Crystal Oscillator: OSCA

The crystal oscillator uses two external pins, XTAL1 for input and XTAL2 for output.

OSCAEN in OSCCON register is an enable signal for the crystal oscillator or for the external oscillator input that can be provided on XTAL1.

High Accurate RC Oscillator: OSCB

The high accuracy RC oscillator needs external R and C components to assure the proper accuracy; its typical frequency is 12 MHz. Frequency accuracy is a function of external R and C accuracy. It is recommended to use 0.5% or better for R and 1% for C components. (Typical values are R = 49.9 K and C = 560 pF)

This oscillator has two modes.

- OSCBEN = 1 and LCKEN = 0: Standard accuracy mode(Typical frequency 12 MHz)
- OSCBEN = 1 and LCKEN = 1: High accuracy mode (Typical frequency 12 MHz).
The OSCB oscillator is based on a low frequency RC oscillator and a VCO. When locked, the oscillator frequency is defined by the following formula:
 $F = 3 \cdot [\text{OSCBFA} + 1] / (R \cdot C)$. with C including parasitic capacitances.
Because the oscillator is based on a PLL, it needs several periods to reach its final accuracy. As soon as this accuracy is reached, the OSCBRY bit in OSCCON register is set by hardware.
The internal frequency is locked on the external RC time constant. So it is possible to adjust frequency by lower than 1% steps with the OSCBFA register. However the frequency adjustment is limited to +/-15% around 12 MHz.
The frequency can be adjusted until 15% around 12 MHz by OSCBFA Register.

OSCBEN and LCKEN are in the OSCCON register.

Low Power Consumption Oscillator: OSCC

The low power consumption RC oscillator doesn't need any external components. Moreover its consumption is very low. Its typical frequency is 14 MHz. Note that this on-chip oscillator has a +/- 40% frequency tolerance and may not be suitable for use in certain applications.

OSCC is set by OSCCEN bit in OSCCON.

Clock Selector

CKS1 and CKS0 bits in CKSEL register are used to select the clock source.

OSCCEN bit in OSCCON register is used to enable the low power consumption RC oscillator.

OSCBEN bit in OSCCON register is used to enable the high accurate RC oscillator.

OSCAEN bit in OSCCON register is used to enable the crystal oscillator or the external oscillator input.

X2 Feature

The AT8xEB5114 core needs only 6 clock periods per machine cycle. This feature called "X2" provides the following advantages:

- Divides frequency crystals by 2 (cheaper crystals) while keeping same CPU power.
- Saves power consumption while keeping same CPU power (oscillator power saving).
- Saves power consumption by dividing dynamically the operating frequency by 2 in operating and idle modes.
- Increases CPU power by 2 while keeping same crystal frequency.

In order to keep the original C51 compatibility, a divider by 2 is inserted between the XTAL1 signal and the main clock input of the core (phase generator). This divider may be enabled or disabled by software.

Description

The clock for the whole circuit and peripherals is first divided by two before being used by the CPU core and the peripherals.

This allows any cyclic ratio to be accepted on XTAL1 input. In X2 mode, as this divider is bypassed, the signals on XTAL1 must have a cyclic ratio from 40 to 60%.

Figure 4 shows the clock generation block diagram. X2 bit is validated on the rising edge of the XTAL1÷2 to avoid glitches when switching from X2 to standard mode. Figure 5 shows the switching mode waveforms.

Figure 5. Mode Switching Waveforms

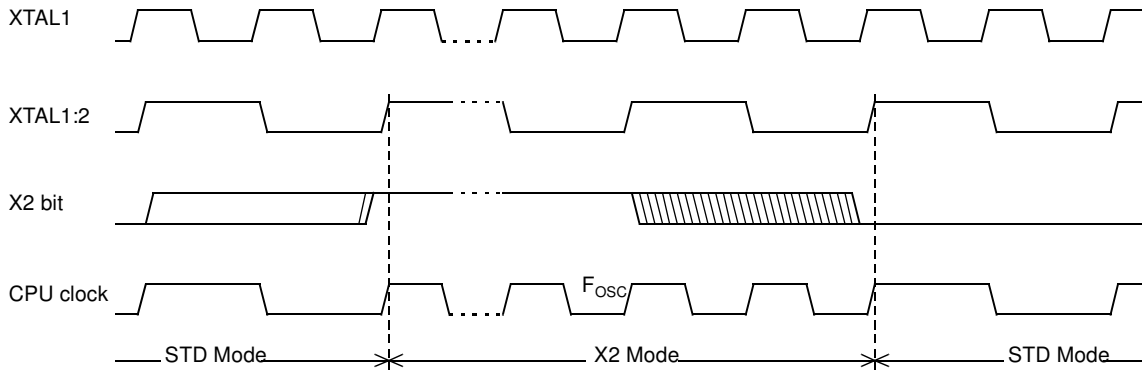

The X2 bit in the CKCON register (see Table 7 on page 18) allows to switch from 12 clock periods per instruction to 6 clock periods and vice versa.

Clock Prescaler

Before supplying the CPU and the peripherals, the main clock is divided by a factor from 2 to 32, as defined by the CKRL register (see Table 6 on page 18). The CPU needs from 12 to 16*12 clock periods per instruction. This allows:

- to accept any cyclic ratio on XTAL1 input.
- to reduce CPU power consumption.

Note: The number of bits of the prescaler is optimized in order to provide a low power consumption in low speed mode (see Section “Electrical Characteristics”, page 84).

Prescaler Divider on Reset

A hardware RESET selects the start oscillator depending on the RST1_OSC and RST0_OSC bits contained on the Hardware Security Byte register (see Table 2 on page 15). It also selects the prescaler divider as follows:

- CKRL = 8h: internal clock = OscOut / 16 (slow CPU speed at reset, thus lower power consumption)
- X2 = 0,
- SEL_OSC1 and SEL_OSC0 bits selects OSCA, OSCB or OSCC, depending on the value of the RST_OSC1 and RST_OSC0 configuration bits.
- After Reset, any value between Fh down to 0h can be written by software into CKRL sfr in order to divide frequency of the selected oscillator:
 - CKRL = 0h: minimum frequency = OscOut / 32
 - CKRL = Fh: maximum frequency = OscOut / 2

The frequency of the CPU and peripherals clock CkOut is related to the frequency of the main oscillator OscOut by the following formula:

$$F_{CkOut} = F_{OscOut} / (32 - 2*CKRL)$$

Some examples can be found in the table below:

F_{OscOut} MHz	X2	CKRL	F_{CkOut} Mhz
12	0	F	6
12	0	E	3
12	1	x	12

- A software instruction which set X2 bit disables the prescaler/divider, so the internal clock is either OSCA, OSCB or OSCC depending on SEL_OSC1 and SEL_OSC0 bits.

Registers

Hardware Security Byte

The security byte sets the starting microcontroller options and the security levels. The default options are X1 mode, Oscillator A and divided by 16 prescaler.

Table 2. Hardware Security Byte (HSB)
Power configuration Register - HSB (S:EFh)

7	6	5	4	3	2	1	0
X2	RST_OSC1	RST_OSC0	RST_OCLK	CKRLRV	-	LB1	LB0
Bit Number	Bit Mnemonic	Description					
7	X2	X2 Mode Clear to force X2 mode (CkOut = OscOut) Set to use the prescaler mode (CkOut = OscOut / (2*(16-M)))					
6	RST_OSC1	Oscillator bit 1 on reset and Oscillator bit 0 on reset 11: allows OSCA 10: allows OSCB 01: allows OSCC 00: reserved					
5	RST_OSC0						
4	RST_OCLK	Output clocking signal after RESET Clear to start the microcontroller with a low level on P3.5 followed by an output clocking signal on P3.5 as soon as the microcontroller is started. This signal has is a 1/3 high 2/3 low signal. Its frequency is equal to (CKout / 3). Set to start on normal conditions: No signal on P3.5 which is pulled up.					
3	CKRLRV	CKRL Reset Value If set, the microcontroller starts with the prescaler reset value = XXXX 1000 (OscOut = CkOut/16). If clear, the microcontroller starts with a prescaler reset value = XXXX 1111 (OscOut = CkOut/2).					
2	-	Reserved					
1-0	LB1-0	User Program Lock Bits See Table 61 on page 81					

HSB = 1111 1X11b

Clock Control Register

The clock control register is used to define the clock system behavior.

Table 3. OSCON Register
OSCCON - Clock Control Register (86h)

7	6	5	4	3	2	1	0
-	-	OSCARY	OSCBRY	LCKEN	OSCCEN	OSCBEN	OSCAEN
Bit Number	Bit Mnemonic	Description					
7	-	Reserved The value read from this bit is indeterminate. Do not set this bit.					
6	-	Reserved The value read from this bit is indeterminate. Do not set this bit.					
5	OSCARY	Oscillator A Ready When set, this bit indicates that Oscillator A is ready to be used.					
4	OSCBRY	Oscillator B Ready When set, this bit indicates that Oscillator B is ready to be used in high accurate mode.					
3	LCKEN	Lock Enable When set, this bit allows to increase the accuracy of OSCB by locking this oscillator on external RC time constant.					
2	OSCCEN	Enable low power consumption RC oscillator This bit is used to enable the low power consumption oscillator 0: The oscillator is disabled 1: The oscillator is enabled.					
1	OSCBEN	Enable high accuracy RC oscillator This bit is used to enable the high accurate RC oscillator 0: The oscillator is disabled 1: The oscillator is enabled.					
0	OSCAEN	Enable crystal oscillator This bit is used to enable the crystal oscillator 0: The oscillator is disabled 1: The oscillator is enabled.					

Reset Value = XXX0

0"RST_OSC1.RST_OSC0""RST_OSC1.RST_OSC0""RST_OSC1.RST_OSC0" b

Not bit addressable

Note: Before changing oscillator selection in CKSEL, be sure that the oscillator you select is started. OSCA is ready as soon as OSCARY is set by hardware, OSCB and OSCC are ready after 4 clock periods. In case you want to use OSCB locked, be sure that OSCB is started before setting LCKEN bit. Then, wait until OSCBRY is set by hardware to be sure that the accurate frequency is reached.

Oscillator B Frequency Adjust Register

The OSCB Frequency Adjust register is used to adjust the frequency in case of external components inaccuracies. It allows a frequency variation about 15% around 12 MHz with a step of around 1%.

Table 4. OSCBFA Register
OSCBFA- Oscillator B Frequency Adjust Register (9Fh)

7	6	5	4	3	2	1	0
OSCBFA7	OSCBFA6	OSCBFA5	OSCBFA4	OSCBFA3	OSCBFA2	OSCBFA1	OSCBFA0
Bit Number	Bit Mnemonic	Description					
7-0	OSCBFA 7-0	OSCB Frequency adjust The reset value to have 12 MHz is 0111 0110. It is possible to modify this value in order to increase or decrease the frequency.					

Reset Value = 0111 0110b
Not bit addressable

Clock Selection Register

The clock selection register is used to define the clock system behavior.

Table 5. CKSEL Register
CKSEL - Clock Selection Register (85h)

7	6	5	4	3	2	1	0
-	-	-	-	-	-	CKS1	CKS0
Bit Number	Bit Mnemonic	Description					
7	-	Reserved The value read from this bit is indeterminate. Do not set this bit.					
6	-	Reserved The value read from this bit is indeterminate. Do not set this bit.					
5	-	Reserved The value read from this bit is indeterminate. Do not set this bit.					
4	-	Reserved The value read from this bit is indeterminate. Do not set this bit.					
3	-	Reserved The value read from this bit is indeterminate. Do not set this bit.					
2	-	Reserved The value read from this bit is indeterminate. Do not set this bit.					
1	CKS1	Active Clock Selector 1 and Active Clock Selector 0 These bits are used to select the active oscillator 11: The crystal oscillator is selected 10: The high accuracy RC oscillator is selected 01: The low power consumption RC oscillator is selected 00: Reserved					
0	CKS0						

Reset Value = XXXX XX"RST_OSC1" "RST_OSC0" b
Not bit addressable

Clock Prescaler Register

This register is used to reload the clock prescaler of the CPU and peripheral clock.

Table 6. CKRL Register
CKRL - Clock prescaler Register (97h)

7	6	5	4	3	2	1	0
-	-	-	-	M			

Bit Number	Bit Mnemonic	Description
7-4	-	Reserved
3-0	CKRL	0000b: Division factor equal 32 1111b: Division factor equal 2 M: Division factor equal $2^{(16-M)}$

Reset Value = XXXX 1000b
Not bit addressable

Clock Control Register

This register is used to control the X2 mode of the CPU and peripheral clock.

Table 7. CKCON Register
CKCON - Clock Control Register (8Fh)

7	6	5	4	3	2	1	0
-	-	-	-	-	-	-	X2

Bit Number	Bit Mnemonic	Description
7-1	-	Reserved
0	X2	X2 Mode Set to force X2 mode (CkOut = OscOut) Clear to use the prescaler mode (CkOut = OscOut / ($2^{(16-M)}$))

Reset Value = 0000 0000b
Not bit addressable

Power Modes

Overview

As seen in the previous chapter it is possible to modify the AT8xEB5114 clock management in order to have less consumption.

For applications where power consumption is a critical factor, three power modes are provided:

- Normal (running) mode
- Idle mode
- Power-down mode

In order to increase ADC accuracy, a Quiet mode also exists. This mode is a pseudo idle mode in which the CPU and all the peripherals except the AD converter are disabled.

Power modes are controlled by PCON SFR register.

Operating Modes

Table 8 summarizes all the power modes and states that AT8xEB5114 can encounter. It shows which parts of AT8xEB5114 are running depending on the operating mode.

Table 8. Operating Modes

Operating Mode	Prescaler	Oscillator	POR	CPU	Peripherals
Power Down			X		
Under Reset		A, B or C	X		
Start	X	A, B or C	X	X	
Running	(X)	A, B or C	X	X	X
Idle	(X)	A, B or C	X		X
Quiet	(X)	A, B or C	X		only ADC

Normal Mode

In normal mode, the oscillator, the CPU and the peripherals are running. The prescaler can also be activated.

- The CPU and the peripherals clock depends on the software selection using CKCON, OSCCON, CKSEL and CKRL registers
- CKS bits select either OSCA, OSCB, or OSCC
- CKRL register determines the frequency of the selected clock, unless X2 bit is set. In this case the prescaler/divider is not used, so CPU core needs only 6-clock periods per machine cycle.

It is always possible to switch dynamically by software from one to another oscillator by changing CKS bits, a synchronization cell allows to avoid any spike during transition.

Idle Mode

The idle mode allows to reduce consumption by freezing the CPU. All the peripherals continue running.

Entering Idle Mode

An instruction that sets PCON.0 causes that to be the last instruction executed before going into Idle mode.

In Idle mode, the internal clock signal is gated off to the CPU, but not to the interrupt, and the peripheral functions. The CPU status is entirely preserved: the Stack Pointer, Program Counter, Program Status Word, Accumulator and all other registers maintain

their data during Idle. The port pins hold the logical states they had at the time Idle was activated. ALE and PSEN are held at logic high levels. The different operating modes are summarized on Table 10 on page 21.

Exit from Idle Mode

There are two ways to terminate idle mode. Activation of any enabled interrupt will cause PCON.0 to be cleared by hardware, terminating Idle mode. The interrupt will be serviced, and following RETI the next instruction to be executed will be the one following the instruction that put the device into idle. Exit from idle mode will leave the oscillators control bits on OSCON and CKS registers unchanged.

The flag bits GF0 and GF1 can be used to give an indication if an interrupt occurred during normal operation or during an Idle mode. For example, an instruction that activates Idle mode can also set one or both flag bits. When Idle is terminated by an interrupt, the interrupt service routine can examine the flag bits.

The other way of terminating the Idle mode is with a hardware reset. Since the clock oscillator is still running, the hardware reset needs to be held active for only two machine cycles (24 oscillator periods) to complete the reset.

In both cases, PCON.0 is cleared by hardware.

Quiet Mode

The quiet mode is a pseudo idle mode in which the CPU and all the peripherals except the AD converter are down. For more details, See “Analog-to-Digital Converter (ADC)” on page 57.

Power-down Mode

To save maximum power, a power-down mode can be invoked by software (refer to Table 11 on page 22). In power-down mode, the oscillator is stopped and the instruction that invoked power-down mode is the last instruction executed. The internal RAM and SFRs retain their value until the power-down mode is terminated. V_{CC} can be lowered to save further power.

Entering Power-down Mode

An instruction that sets PCON.1 causes that to be the last instruction executed before going into the power-down mode.

The ports status under power-down is the previous status before entering this power mode.

Exit from Power-down Mode

Either a hardware reset or an external interrupt (low level) on $\overline{INT0}$ or $\overline{INT1}$ (if enabled) can cause an exit from power-down. To properly terminate power-down, the reset or external interrupt should not be executed before V_{CC} is restored to its normal operating level and must be held active long enough for the oscillator to restart and stabilize.

Exit from power-down by external interrupt does not affect the SFRs and the internal RAM content.

Figure 6. Power-down Exit Waveform

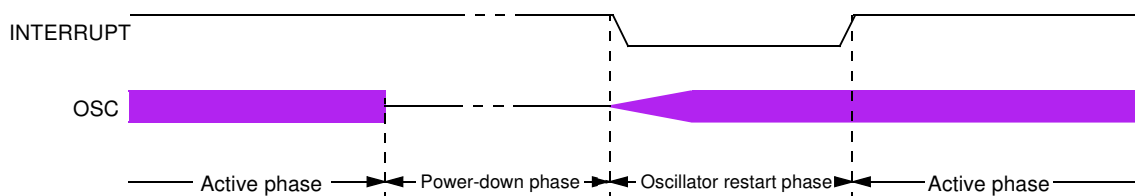

By a hardware Reset, the CPU will restart in the mode defined by the RST_OSC1 and RST_OSC0 bits in HSB.

By INT1 and INT0 interruptions (if enabled), the oscillators control bits on OSCON and CKSEL will be kept, so the selected oscillator before entering in power-down mode will be activated. Only external interrupts INT0 and INT1 are useful to exit from power-down.

Note: Exit from power down mode doesn't depend on IT0 and IT1 configurations. It is only possible to exit from power down mode on a low level on these pins.

Holding the pin low restarts the oscillator but bringing the pin high completes the exit as detailed in Figure 6. When both interrupts are enabled, the oscillator restarts as soon as one of the two inputs is held low and power down exit will be completed when the first input is released. In this case the higher priority interrupt service routine is executed.

Table 9 shows the state of ports during idle and power-down modes.

Table 9. Ports State

Mode	Program Memory	Port3	Port4
Idle	Internal	Port Data	Port Data
Power Down	Internal	Port Data	Port Data

Table 10. Operating Modes

PD	IDLE	CKS1	CKS0	OSCCEN	OSCBEN	OSCAEN	Selected Mode	Comment
0	0	1	1	X	X	1	NORMAL MODE A	OSCA: XTAL clock
X	X	1	1	X	X	0	INVALID	no active clock
0	0	1	0	X	1	X	NORMAL MODE B,	OSCB: high accuracy RC clock
X	X	1	0	X	0	X	INVALID	no active clock
0	0	0	1	1	X	X	NORMAL MODE C,	OSCC: low consumption RC clock
X	X	0	1	0	X	X	INVALID	no active clock
0	1	1	1	X	X	1	IDLE MODE A	The CPU is off, OSCA supplies the peripherals
0	1	1	0	X	1	X	IDLE MODE B	The CPU is off, OSCB supplies the peripherals
0	1	0	1	1	X	X	IDLE MODE C	The CPU is off, OSCC supplies the peripherals
1	X	X	X	X	X	X	POWER DOWN	The CPU is off, OSCA, OSCB and OSCC are stopped

Power Modes Control Registers

Table 11. PCON Register
PCON (S:87h)
Power configuration Register

7	6	5	4	3	2	1	0
-	-	-	-	GF1	GF0	PD	IDL

Bit Number	Bit Mnemonic	Description
7		Reserved
6		Reserved
5		Reserved
4		Reserved
3	GF1	General Purpose flag 1 Set and Cleared by user for general purpose usage.
2	GF0	General Purpose flag 0 Set and Cleared by user for general purpose usage.
1	PD	Power-down Mode bit Cleared by hardware when an interrupt or reset occurs. Set to activate the Power-down mode. If IDL and PD are both set, PD takes precedence.
0	IDL	Idle Mode bit Cleared by hardware when an interrupt or reset occurs. Set to activate the Idle mode. If IDL and PD are both set, PD takes precedence.

Reset Value = 00XX XX00b

AUXR Register

Table 12. AUXR Register
AUXR - Auxiliary Register (8Eh)

7	6	5	4	3	2	1	0
DPU	-	-	LOWVD	-	-	-	-

Bit Number	Bit Mnemonic	Description
7	DPU	Disable Pull up Set to disable each pull up on all ports. Clear to connect all pull-ups on each port.
6	-	Reserved The value read from this bit is indeterminate. Do not set this bit.
5	-	Reserved The value read from this bit is indeterminate. Do not set this bit.
4	LOWVD	Low Voltage Detection This bit is clear by hardware when the supply voltage is under V _{pfdp} value. This bit is set by hardware as soon the supply voltage is greater than V _{pfdp} value.
3-1	-	Reserved The value read from this bit is indeterminate. Do not set this bit.
0	-	Reserved The value read from this bit is indeterminate. Do not set this bit.

Reset Value = 0XX0 XXXXb
Not bit addressable

Timers/Counters

Introduction

The AT8xEB5114 implements two general-purpose, 16-bit Timers/Counters. Although they are identified as Timer 0, Timer 1, they can be independently configured each to operate in a variety of modes as a Timer or as an event Counter. When operating as a Timer, a Timer/Counter runs for a programmed length of time, then issues an interrupt request. When operating as a Counter, a Timer/Counter counts negative transitions on an external pin. After a preset number of counts, the Counter issues an interrupt request.

The Timer registers and associated control registers are implemented as addressable Special Function Registers (SFRs). Two of the SFRs provide programmable control of the Timers as follows:

- Timer/Counter mode control register (TMOD) and Timer/Counter control register (TCON) control both Timer 0 and Timer 1.

The various operating modes of each Timer/Counter are described below.

Timer/Counter Operations

A basic operation is Timer registers THx and TLx ($x = 0, 1$) connected in cascade to form a 16-bit Timer. Setting the run control bit (TRx) in the TCON register (see Figure 15) turns the Timer on by allowing the selected input to increment TLx. When TLx overflows it increments THx and when THx overflows it sets the Timer overflow flag (TFx) in the TCON register. Setting the TRx does not clear the THx and TLx Timer registers. Timer registers can be accessed to obtain the current count or to enter preset values. They can be read at any time but the TRx bit must be cleared to preset their values, otherwise the behavior of the Timer/Counter is unpredictable.

The C/Tx# control bit selects Timer operation or Counter operation by selecting the divided-down system clock or the external pin Tx as the source for the counted signal. The TRx bit must be cleared when changing the operating mode, otherwise the behavior of the Timer/Counter is unpredictable.

For Timer operation ($C/Tx\# = 0$), the Timer register counts the divided-down system clock. The Timer register is incremented once every peripheral cycle.

For Counter operation ($C/Tx\# = 1$), the Timer register counts the negative transitions on the external input pin Tx. The external input is sampled during every S5P2 state. The Programmer's Guide describes the notation for the states in a peripheral cycle. When the sample is high in one cycle and low in the next one, the Counter is incremented. The new count value appears in the register during the next S3P1 state after the transition has been detected. Since it takes 12 states (24 oscillator periods in X1 mode) to recognize a negative transition, the maximum count rate is 1/24 of the oscillator frequency in X1 mode. There are no restrictions on the duty cycle of the external input signal, but to ensure that a given level is sampled at least once before it changes, it should be held for at least one full peripheral cycle.

Timer 0

Timer 0 functions as either a Timer or an event Counter in four operating modes. Figure 7 to Figure 10 show the logic configuration of each mode.

Timer 0 is controlled by the four lower bits of the TMOD register (see Figure 16) and bits 0, 1, 4 and 5 of the TCON register (see Figure 15). The TMOD register selects the method of Timer gating (GATE0), Timer or Counter operation (T/C0#) and the operating mode (M10 and M00). The TCON register provides Timer 0 control functions: overflow flag (TF0), run control bit (TR0), interrupt flag (IE0) and interrupt type control bit (IT0).

For normal Timer operation ($GATE0 = 0$), setting TR0 allows TL0 to be incremented by the selected input. Setting GATE0 and TR0 allows external pin INT0# to control Timer

operation.

Timer 0 overflow (count rolls over from all 1s to all 0s) sets the TF0 flag and generates an interrupt request.

It is important to stop the Timer/Counter before changing modes.

Mode 0 (13-bit Timer)

Mode 0 configures Timer 0 as a 13-bit Timer which is set up as an 8-bit Timer (TH0 register) with a modulo-32 prescaler implemented with the lower five bits of the TL0 register (see Figure 7). The upper three bits of the TL0 register are indeterminate and should be ignored. Prescaler overflow increments the TH0 register.

Figure 7. Timer/Counter x (x= 0 or 1) in Mode 0

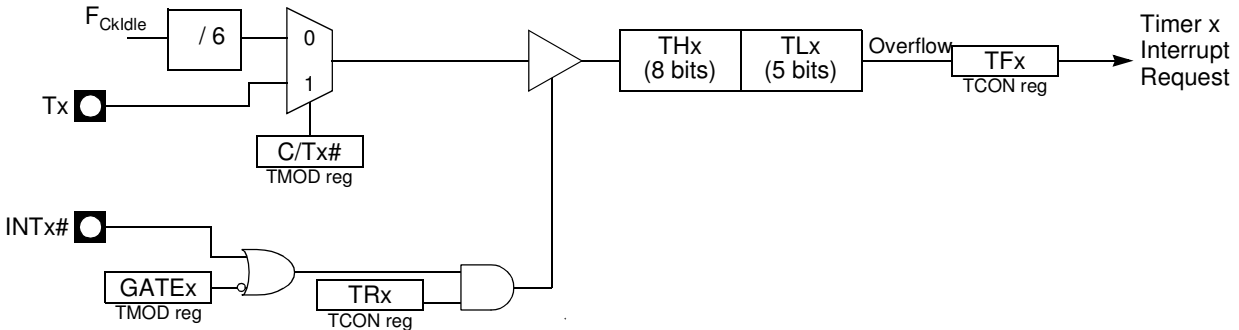

Mode 1 (16-bit Timer)

Mode 1 configures Timer 0 as a 16-bit Timer with the TH0 and TL0 registers connected in a cascade (see Figure 8). The selected input increments the TL0 register.

Figure 8. Timer/Counter x (x = 0 or 1) in Mode 1

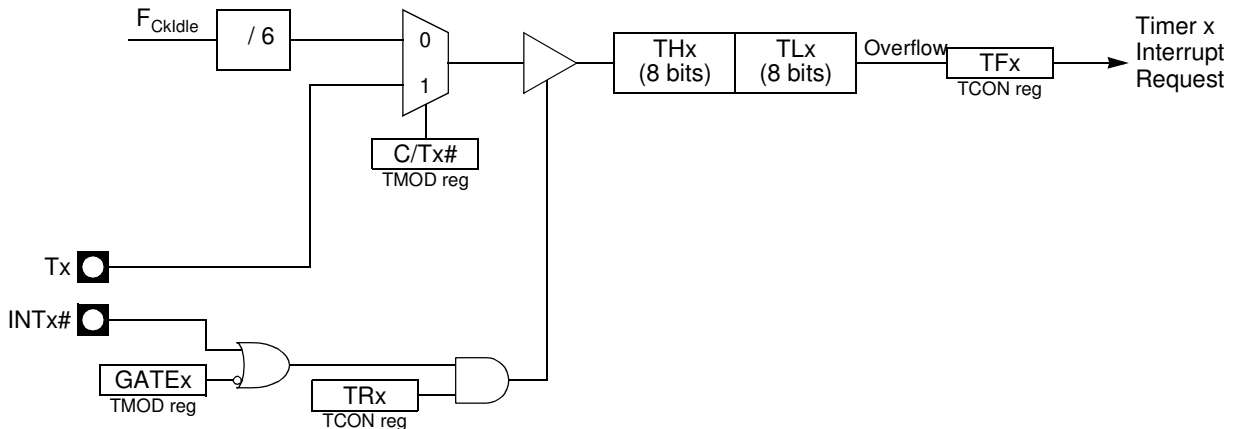

Mode 2 (8-bit Timer with Auto-Reload)

Mode 2 configures Timer 0 as an 8-bit Timer (TL0 register) that automatically reloads from the TH0 register on overflow (see Figure 9). TL0 overflow sets the TF0 flag in the TCON register and reloads TL0 with the contents of TH0, which is preset by the software. When the interrupt request is serviced, the hardware clears TF0. The reload leaves TH0 unchanged. The next reload value may be changed at any time by writing it to the TH0 register.

Figure 9. Timer/Counter x (x = 0 or 1) in Mode 2

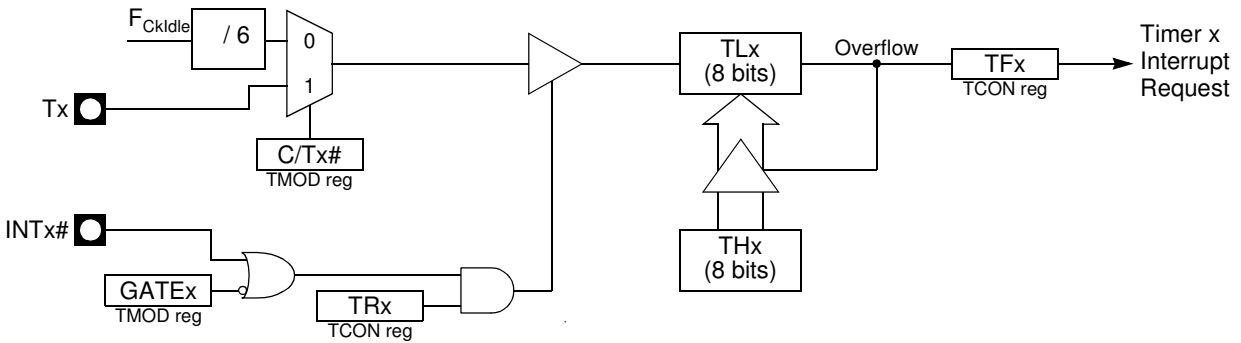

Mode 3 (Two 8-bit Timers)

Mode 3 configures Timer 0 so that registers TL0 and TH0 operate as 8-bit Timers (see Figure 10). This mode is provided for applications requiring an additional 8-bit Timer or Counter. TL0 uses the Timer 0 control bits C/T0# and GATE0 in the TMOD register, and TR0 and TF0 in the TCON register in the normal manner. TH0 is locked into a Timer function (counting F_{UART}) and takes over use of the Timer 1 interrupt (TF1) and run control (TR1) bits. Thus, operation of Timer 1 is restricted when Timer 0 is in mode 3.

Figure 10. Timer/Counter 0 in Mode 3: Two 8-bit Counters

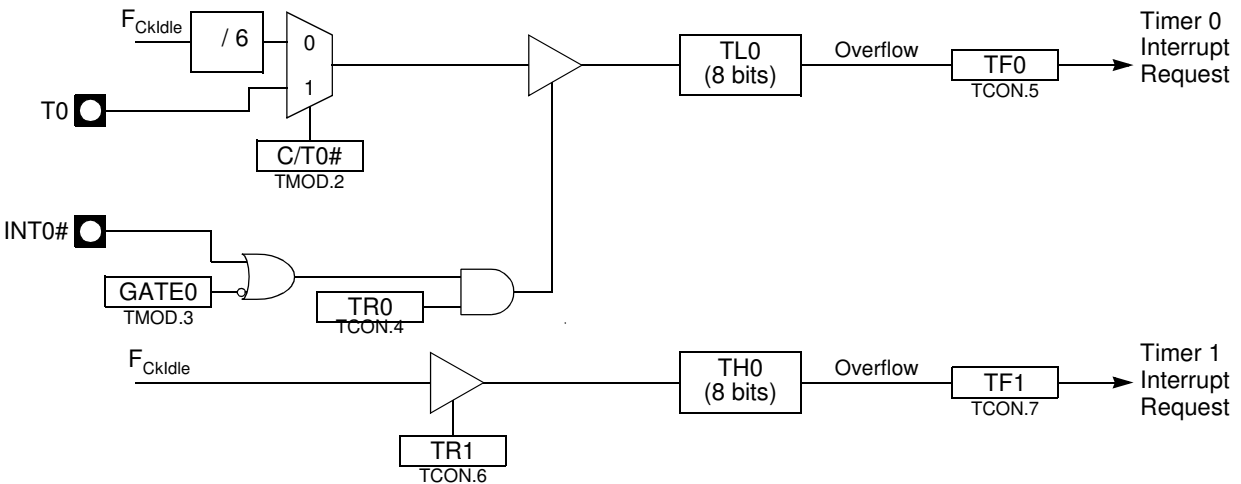

Timer 1

Timer 1 is identical to Timer 0 except for Mode 3 which is a hold-count mode. The following comments help to understand the differences:

- Timer 1 functions as either a Timer or an event Counter in the three operating modes. Figure 7 to Figure 9 show the logical configuration for modes 0, 1, and 2. Mode 3 of Timer 1 is a hold-count mode.
- Timer 1 is controlled by the four high-order bits of the TMOD register (see Figure 16) and bits 2, 3, 6 and 7 of the TCON register (see Figure 15). The TMOD register selects the method of Timer gating (GATE1), Timer or Counter operation (C/T1#) and the operating mode (M11 and M01). The TCON register provides Timer 1 control functions: overflow flag (TF1), run control bit (TR1), interrupt flag (IE1) and the interrupt type control bit (IT1).
- Timer 1 can serve as the Baud Rate Generator for the Serial Port. Mode 2 is best suited for this purpose.

- For normal Timer operation (GATE1= 0), setting TR1 allows TL1 to be incremented by the selected input. Setting GATE1 and TR1 allows external pin INT1# to control Timer operation.
- Timer 1 overflow (count rolls over from all 1s to all 0s) sets the TF1 flag and generates an interrupt request.
- When Timer 0 is in mode 3, it uses Timer 1's overflow flag (TF1) and run control bit (TR1). For this situation, use Timer 1 only for applications that do not require an interrupt (such as a Baud Rate Generator for the Serial Port) and switch Timer 1 in and out of mode 3 to turn it off and on.
- It is important to stop the Timer/Counter before changing modes.

Mode 0 (13-bit Timer)

Mode 0 configures Timer 1 as a 13-bit Timer, which is set up as an 8-bit Timer (TH1 register) with a modulo-32 prescaler implemented with the lower 5 bits of the TL1 register (see Figure 7). The upper 3 bits of TL1 register are indeterminate and should be ignored. Prescaler overflow increments the TH1 register.

Mode 1 (16-bit Timer)

Mode 1 configures Timer 1 as a 16-bit Timer with TH1 and TL1 registers connected in cascade (see Figure 8). The selected input increments the TL1 register.

Mode 2 (8-bit Timer with Auto-Reload)

Mode 2 configures Timer 1 as an 8-bit Timer (TL1 register) with automatic reload from the TH1 register on overflow (see Figure 9). TL1 overflow sets the TF1 flag in the TCON register and reloads TL1 with the contents of TH1, which is preset by the software. The reload leaves TH1 unchanged.

Mode 3 (Halt)

Placing Timer 1 in mode 3 causes it to halt and hold its count. This can be used to halt Timer 1 when the TR1 run control bit is not available i.e. when Timer 0 is in mode 3.

Registers

Table 13. TCON (S:88h)
Timer/Counter Control Register

7	6	5	4	3	2	1	0
TF1	TR1	TF0	TR0	IE1	IT1	IE0	IT0
Bit Number	Bit Mnemonic	Description					
7	TF1	Timer 1 Overflow flag Cleared by the hardware when processor vectors to interrupt routine. Set by the hardware on Timer 1 register overflows.					
6	TR1	Timer 1 Run Control bit Clear to turn off Timer/Counter 1. Set to turn on Timer/Counter 1.					
5	TF0	Timer 0 Overflow flag Cleared by the hardware when processor vectors to interrupt routine. Set by the hardware on Timer 0 register overflows.					
4	TR0	Timer 0 Run Control bit Clear to turn off Timer/Counter 0. Set to turn on Timer/Counter 0.					
3	IE1	Interrupt 1 Edge flag Cleared by the hardware as soon as the interrupt is processed. Set by the hardware when external interrupt is detected on the $\overline{INT1}$ pin.					
2	IT1	Interrupt 1 Type Control bit Clear to select low level active for external interrupt 1 ($\overline{INT1}$). Set to select sensitive edge trigger for external interrupt 1. The sensitive edge (Rising or Falling) is determined by ESB1 value (Edge Selection Bit 1) in IOR (Interrupt Option Register).					
1	IE0	Interrupt 0 Edge flag Cleared by the hardware as soon as the interrupt is processed. Set by the hardware when external interrupt is detected on $\overline{INT0}$ pin.					
0	IT0	Interrupt 0 Type Control bit Clear to select low level active trigger for external interrupt 0 ($\overline{INT0}$). Set to select sensitive edge trigger for external interrupt 0. The sensitive edge (Rising or Falling) is determined by ESB0 (Edge Selection Bit 0) in IOR (Interrupt Option Register).					

Reset Value = 0000 0000b

Table 14. IOR (S:A5h)
Interrupt Option Register.

7	6	5	4	3	2	1	0
-	-	-	-	-	-	ESB1	ESB0

Bit Number	Bit Mnemonic	Description
7-2	-	Reserved The value read from this bit is indeterminate. Do not set this bit.
1	ESB1	Edge Selection bit for $\overline{\text{INT1}}$ Clear to select falling edge sensitive for $\overline{\text{INT1}}$ pin. Set to select rising edge sensitive for $\overline{\text{INT1}}$ pin.
0	ESB0	Edge Selection bit for $\overline{\text{INT0}}$ Clear to select falling edge sensitive for $\overline{\text{INT0}}$ pin. Set to select rising edge sensitive for $\overline{\text{INT0}}$ pin.

Reset Value = XXXX XX00b

Table 15. TMOD Register
TMOD (S:89h)
 Timer/Counter Mode Control Register.

	7	6	5	4	3	2	1	0
	GATE1	C/T1#	M11	M01	GATE0	C/T0#	M10	M00

Bit Number	Bit Mnemonic	Description																									
7	GATE1	Timer 1 Gating Control bit Clear to enable Timer counter 1 whenever TR1 bit is set. Set to enable Timer counter 1 only while INT1# pin is high and TR1 bit is set.																									
6	C/T1#	Timer 1 Counter/Timer Select bit Clear for Timer operation: Timer 1 counts the divided-down system clock. Set for Counter operation: Timer 1 counts negative transitions on external pin T1.																									
5	M11	Timer 1 Mode Select bits																									
4	M01	<table border="0" style="width:100%; border-collapse: collapse;"> <tr> <td style="width:10%;"></td> <td style="width:10%;"><u>M11</u></td> <td style="width:10%;"><u>M01</u></td> <td style="width:10%;"><u>Operating mode</u></td> <td></td> </tr> <tr> <td></td> <td>0</td> <td>0</td> <td>Mode 0:</td> <td>8-bit Timer/Counter (TH1) with 5-bit prescaler (TL1).</td> </tr> <tr> <td></td> <td>0</td> <td>1</td> <td>Mode 1:</td> <td>16-bit Timer/Counter.</td> </tr> <tr> <td></td> <td>1</td> <td>0</td> <td>Mode 2:</td> <td>8-bit auto-reload Timer/Counter (TL1). Reloaded from TH1 at overflow.</td> </tr> <tr> <td></td> <td>1</td> <td>1</td> <td>Mode 3:</td> <td>Timer 1 halted. Retains count.</td> </tr> </table>		<u>M11</u>	<u>M01</u>	<u>Operating mode</u>			0	0	Mode 0:	8-bit Timer/Counter (TH1) with 5-bit prescaler (TL1).		0	1	Mode 1:	16-bit Timer/Counter.		1	0	Mode 2:	8-bit auto-reload Timer/Counter (TL1). Reloaded from TH1 at overflow.		1	1	Mode 3:	Timer 1 halted. Retains count.
	<u>M11</u>	<u>M01</u>	<u>Operating mode</u>																								
	0	0	Mode 0:	8-bit Timer/Counter (TH1) with 5-bit prescaler (TL1).																							
	0	1	Mode 1:	16-bit Timer/Counter.																							
	1	0	Mode 2:	8-bit auto-reload Timer/Counter (TL1). Reloaded from TH1 at overflow.																							
	1	1	Mode 3:	Timer 1 halted. Retains count.																							
3	GATE0	Timer 0 Gating Control bit Clear to enable Timer counter 0 whenever TR0 bit is set. Set to enable Timer counter 0 only while INT0# pin is high and TR0 bit is set.																									
2	C/T0#	Timer 0 Counter/Timer Select bit Clear for Timer operation: Timer 0 counts the divided-down system clock. Set for Counter operation: Timer 0 counts negative transitions on external pin T0.																									
1	M10	Timer 0 Mode Select bit																									
0	M00	<table border="0" style="width:100%; border-collapse: collapse;"> <tr> <td style="width:10%;"></td> <td style="width:10%;"><u>M10</u></td> <td style="width:10%;"><u>M00</u></td> <td style="width:10%;"><u>Operating mode</u></td> <td></td> </tr> <tr> <td></td> <td>0</td> <td>0</td> <td>Mode 0:</td> <td>8-bit Timer/Counter (TH0) with 5-bit prescaler (TL0).</td> </tr> <tr> <td></td> <td>0</td> <td>1</td> <td>Mode 1:</td> <td>16-bit Timer/Counter.</td> </tr> <tr> <td></td> <td>1</td> <td>0</td> <td>Mode 2:</td> <td>8-bit auto-reload Timer/Counter (TL0). Reloaded from TH0 at overflow</td> </tr> <tr> <td></td> <td>1</td> <td>1</td> <td>Mode 3:</td> <td>TL0 is an 8-bit Timer/Counter</td> </tr> </table> TH0 is an 8-bit Timer using Timer 1's TR0 and TF0 bits.		<u>M10</u>	<u>M00</u>	<u>Operating mode</u>			0	0	Mode 0:	8-bit Timer/Counter (TH0) with 5-bit prescaler (TL0).		0	1	Mode 1:	16-bit Timer/Counter.		1	0	Mode 2:	8-bit auto-reload Timer/Counter (TL0). Reloaded from TH0 at overflow		1	1	Mode 3:	TL0 is an 8-bit Timer/Counter
	<u>M10</u>	<u>M00</u>	<u>Operating mode</u>																								
	0	0	Mode 0:	8-bit Timer/Counter (TH0) with 5-bit prescaler (TL0).																							
	0	1	Mode 1:	16-bit Timer/Counter.																							
	1	0	Mode 2:	8-bit auto-reload Timer/Counter (TL0). Reloaded from TH0 at overflow																							
	1	1	Mode 3:	TL0 is an 8-bit Timer/Counter																							

Reset Value = 0000 0000b

Table 16. TH0 Register
TH0 (S:8Ch)
 Timer 0 High Byte Register.

	7	6	5	4	3	2	1	0

Bit Number	Bit Mnemonic	Description
7:0		High Byte of Timer 0.

Reset Value = 0000 0000b

Table 17. TL0 Register

TL0 (S:8Ah)

Timer 0 Low Byte Register.

7	6	5	4	3	2	1	0
Bit Number	Bit Mnemonic	Description					
7:0		Low Byte of Timer 0.					

Reset Value = 0000 0000b

Table 18. TH1 Register

TH1 (S:8Dh)

Timer 1 High Byte Register.

7	6	5	4	3	2	1	0
Bit Number	Bit Mnemonic	Description					
7:0		High Byte of Timer 1.					

Reset Value = 0000 0000b

Table 19. TL1 Register

TL1 (S:8Bh)

Timer 1 Low Byte Register.

7	6	5	4	3	2	1	0
Bit Number	Bit Mnemonic	Description					
7:0		Low Byte of Timer 1.					

Reset Value = 0000 0000b

Ports

The AT8xEB5114 has 2 I/O ports, port 3, and port 4.

All port3 and port4 I/O port pins on the AT8xEB5114 may be software configured to one of four types on a bit-by-bit basis, as shown below in Table 20. These are: quasi-bidirectional (standard 80C51 port outputs), push-pull, open drain, and input only. Two configuration registers for each port select the output type for each port pin.

Table 20. Port Output Configuration setting using PxM1 and PxM2 registers ($3 \leq x \leq 4$)

PxM1.(2y+1) bit	PxM1.(2y) bit	($0 \leq y \leq 3$) Port Output Mode
0	0	Quasi bidirectional
0	1	Push-Pull
1	0	Input Only (High Impedance)
1	1	Open Drain

PxM2.(2y-7) bit	PxM2.(2y-8) bit	($4 \leq y \leq 7$) Port Output Mode
0	0	Quasi bidirectional
0	1	Push-Pull
1	0	Input Only (High Impedance)
1	1	Open Drain

Port Types

Quasi-Bidirectional Output Configuration

The default port output configuration for standard AT8xEB5114 I/O ports is the quasi-bidirectional output that is common on the 80C51 and most of its derivatives. This output type can be used as both an input and output without the need of reconfiguring the port. This is possible because when the port outputs a logic high, it is weakly driven, allowing an external device to pull the pin low. When the pin is pulled low, it is driven strongly and able to sink a fairly large current. These features are somewhat similar to an open drain output except that there are three pull-up transistors in the quasi-bidirectional output that serve different purposes. One of these pull-ups, called the "weak" pull-up, is turned on whenever the port latch for the pin contains a logic 1. The weak pull-up sources a very small current that will pull the pin high if it is left floating. A second pull-up, called the "medium" pull-up, is turned on when the port latch for the pin contains a logic 1 and the pin itself is also at a logic 1 level. This pull-up provides the primary source current for a quasi-bidirectional pin that is outputting a 1. If a pin that has a logic 1 on it is pulled low by an external device, the medium pull-up turns off, and only the weak pull-up remains on. In order to pull the pin low under these conditions, the external device has to sink enough current to overpower the medium pull-up and take the voltage on the port pin below its input threshold.

The third pull-up is referred to as the "strong" pull-up. This pull-up is used to speed up low-to-high transitions on a quasi-bidirectional port pin when the port latch changes from a logic 0 to a logic 1. When this occurs, the strong pull-up turns on for a brief time, two CPU clocks, in order to pull the port pin high quickly. Then it turns off again.

The quasi-bidirectional port configuration is shown in Figure 11.

Figure 11. Quasi-Bidirectional Output

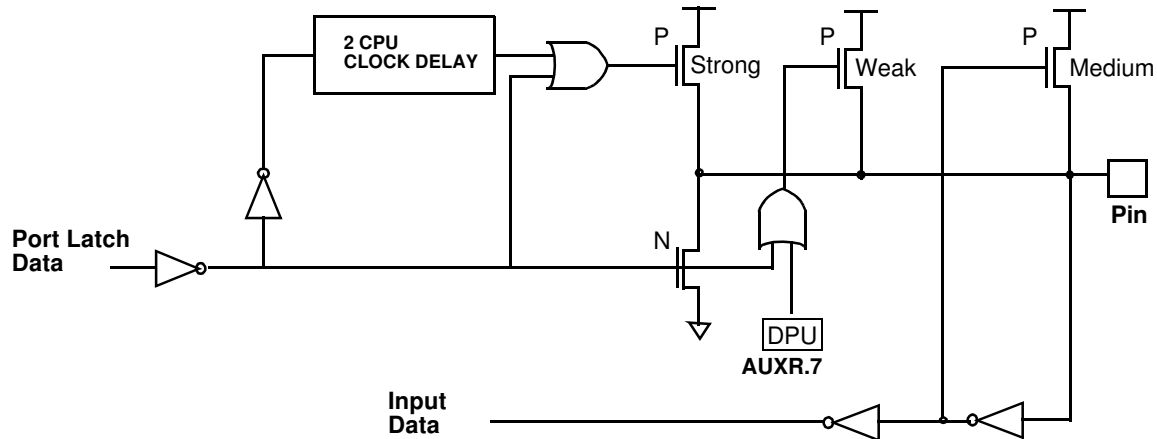

Open Drain Output Configuration

The open drain output configuration turns off all pull-ups and only drives the pull-down transistor of the port driver when the port latch contains a logic 0. To be used as a logic output, a port configured in this manner must have an external pull-up, typically a resistor tied to V_{DD} . The pull-down for this mode is the same as the quasi-bidirectional mode. The open drain port configuration is shown in Figure 12.

Figure 12. Open Drain Output

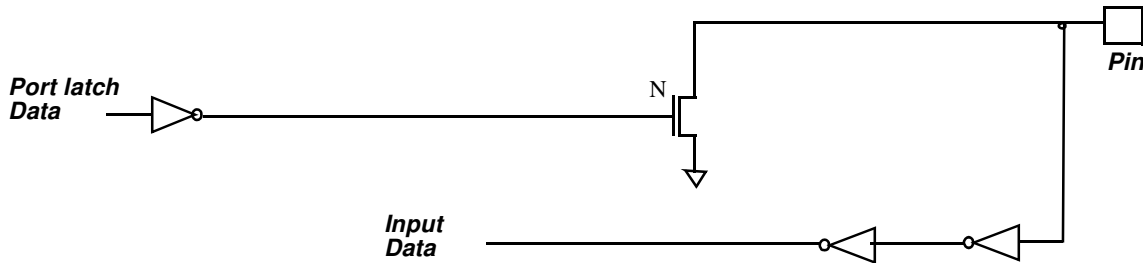

Push-Pull Output Configuration

The push-pull output configuration has the same pull-down structure as both the open drain and the quasi-bidirectional output modes, but provides a continuous strong pull-up when the port latch contains a logic 1. The push-pull mode may be used when more source current is needed from a port output. The push-pull port configuration is shown in Figure 13.

Figure 13. Push-Pull Output

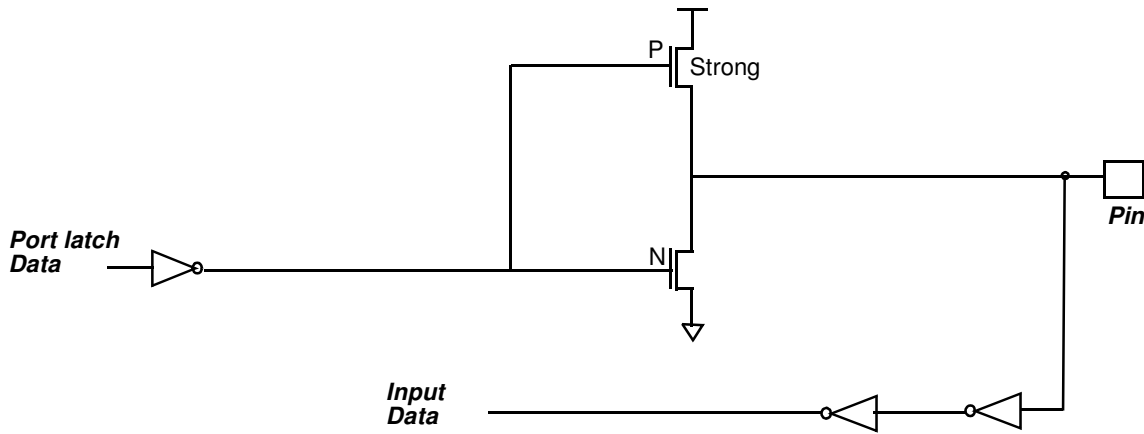

Input only Configuration

The input only configuration is a pure input with neither pull-up nor pull-down. The input only configuration is shown in Figure 13.

Figure 14. Input only

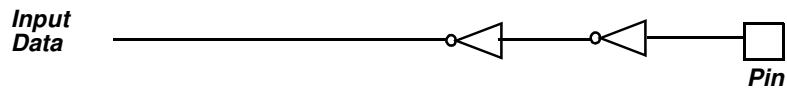

Ports Description

Ports P3 and P4

The inputs of each I/O port of the AT8xEB5114 are TTL level Schmitt triggers with hysteresis.

Registers

Table 21. P3M1 Register
P3M1 Address (D5h)

7	6	5	4	3	2	1	0
P3M1.7	P3M1.6	P3M1.5	P3M1.4	P3M1.3	P3M1.2	P3M1.1	P3M1.0
Bit Number	Bit Mnemonic	Description					
7-6	P3M1.7-6	Port 3.3 Output configuration bit See Table 20 for configuration definition					
5-4	P3M1.5-4	Port 3.2 Output configuration bit See Table 20 for configuration definition					
3-2	P3M1.3-2	Port 3.1 Output configuration bit See Table 20 for configuration definition					
1-0	P3M1.1-0	Port 3.0 Output configuration bit See Table 20 for configuration definition					

Reset value = 0000 0000

Table 22. P3M2 Register
P3M2 Address (E4h)

7	6	5	4	3	2	1	0
P3M2.7	P3M2.6	P3M2.5	P3M2.4	P3M2.3	P3M2.2	P3M2.1	P3M2.0
Bit Number	Bit Mnemonic	Description					
7-6	P3M2.7-6	Port 3.7 Output configuration bit See Table 20 for configuration definition					
5-4	P3M2.5-4	Port 3.6 Output configuration bit See Table 20 for configuration definition					
3-2	P3M2.3-2	Port 3.5 Output configuration bit See Table 20 for configuration definition					
1-0	P3M2.1-0	Port 3.4 Output configuration bit See Table 20 for configuration definition					

Reset value = 0000 0000

Table 23. P4M1 Register
P4M1 Address (D6h)

7	6	5	4	3	2	1	0
P4M1.7	P4M1.6	P4M1.5	P4M1.4	P4M1.3	P4M1.2	P4M1.1	P4M1.0
Bit Number	Bit Mnemonic	Description					
7-6	P4M1.7-6	Port 4.3 Output configuration bit See Table 20 for configuration definition					
5-4	P4M1.5-4	Port 4.2 Output configuration bit See Table 20 for configuration definition					
3-2	P4M1.3-2	Port 4.1 Output configuration bit See Table 20 for configuration definition					
1-0	P4M1.1-0	Port 4.0 Output configuration bit See Table 20 for configuration definition					

Reset value = 0000 0000

Dual Data Pointer Register (DDPTR)

The additional data pointer can be used to speed up code execution and reduce code size in a number of ways.

The dual DPTR structure is a way by which the chip will specify the address of an external data memory location. There are two 16-bit DPTR registers that address the external memory, and a single bit called DPS = AUXR1/bit0 (See Figure 15) that allows the program code to switch between them.

Figure 15. Use of Dual Pointer

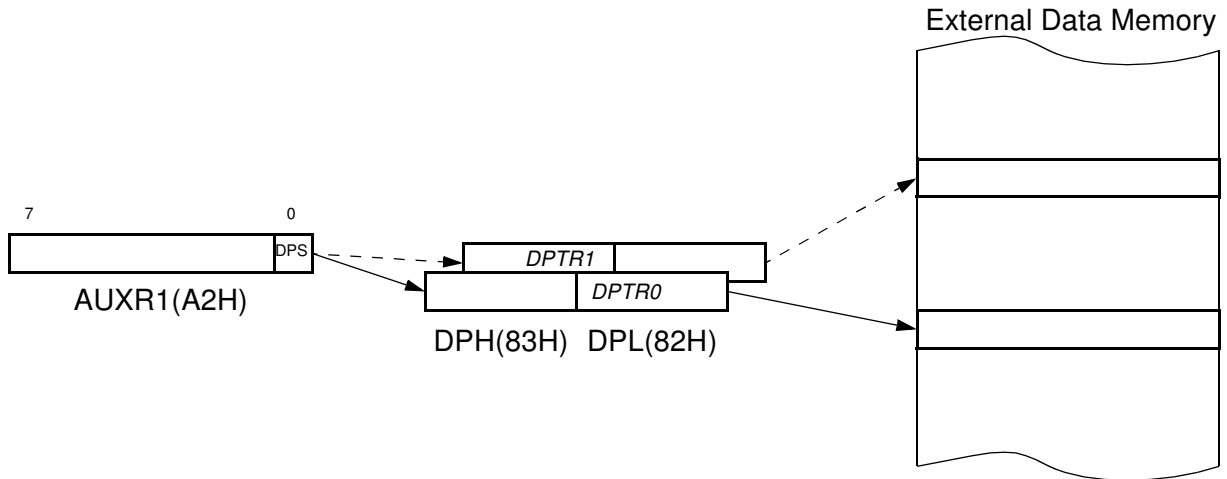

Table 24. AUXR1: Auxiliary Register 1

7	6	5	4	3	2	1	0
-	-	-	-	-	0	-	DPS

Bit Number	Bit Mnemonic	Description
7	-	Reserved The value read from this bit is indeterminate. Do not set this bit.
6	-	Reserved The value read from this bit is indeterminate. Do not set this bit.
5	-	Reserved The value read from this bit is indeterminate. Do not set this bit.
4	-	Reserved The value read from this bit is indeterminate. Do not set this bit.
3	-	Reserved The value read from this bit is indeterminate. Do not set this bit.
2	0	Reserved always stuck at 0
1	-	Reserved The value read from this bit is indeterminate. Do not set this bit.
0	DPS	Data Pointer Selection Clear to select DPTR0. Set to select DPTR1.

Note: User software should not write 1's to reserved bits. These bits may be used in future 8051 family products to invoke new feature. In that case, the reset value of the new bit will be 0, and its active value will be 1. The value read from a reserved bit is indeterminate.

Application

Software can take advantage of the additional data pointers to both increase speed and reduce code size, for example, block operations (copy, compare, search...) are well served by using one data pointer as a 'source' pointer and the other one as a 'destination' pointer.

ASSEMBLY LANGUAGE

```

; Block move using dual data pointers
; Destroys DPTR0, DPTR1, A and PSW
; note: DPS exits opposite of entry state
; unless an extra INC AUXR1 is added
;
00A2  AUXR1 EQU 0A2H
;
0000 909000MOV DPTR,#SOURCE ; address of SOURCE
0003 05A2 INC AUXR1 ; switch data pointers
0005 90A000 MOV DPTR,#DEST ; address of DEST
0008  LOOP:
0008 05A2 INC AUXR1 ; switch data pointers
000A E0 MOVX A,@DPTR ; get a byte from SOURCE
000B A3 INC DPTR ; increment SOURCE address
000C 05A2 INC AUXR1 ; switch data pointers
000E F0 MOVX @DPTR,A ; write the byte to DEST
000F A3 INC DPTR ; increment DEST address
0010 70F6JNZ LOOP ; check for 0 terminator
0012 05A2 INC AUXR1 ; (optional) restore DPS

```

INC is a short (2 bytes) and fast (12 clocks) way to manipulate the DPS bit in the AUXR1 SFR. However, note that the INC instruction does not directly force the DPS bit to a particular state, but simply toggles it. In simple routines, such as the block move example, only the fact that DPS is toggled in the proper sequence matters, not its actual value. In other words, the block move routine works the same whether DPS is '0' or '1' on entry. Observe that without the last instruction (INC AUXR1), the routine will exit with DPS in the opposite state.

PWM Unit 0 (PWMU0)

The PWM unit 0 allows to generate precise pulse width modulation with variable duty cycle and frequency.

The PWMU0 consists on a dedicated 16 bits auto reload counter/timer which serves as a time base for the generation of 3 independent PWM signals.

Its clock input can be programmed to count any one of the following signals:

- Peripheral clock, CkIdle
- Timer 0 overflow
- External input on W0CI (P4.0)

The PWMU0 timer/counter shares several external I/O. These pins are listed below. If a port is not used for the PWMU0, it can still be used for standard I/O.

PWMU0 Component	External I/O Pin
16-bit Counter	W0CI (P4.0)
16-bit Module 0	W0M0 (P3.0)
16-bit Module 1	W0M1 (P3.1)
16-bit Module 2	W0M2 (P3.3)

PWMU0 Timer

The PWMU0 timer is a common 16 bits time base for all three modules (See Figure 16). The timer count source is determined from the W0CPS1 and W0CPS0 bits in the W0MOD register (See Table 26) and can be programmed to run at:

- Peripheral clock, CkIdle
- Timer 0 overflow
- External input on W0CI (P1.2)

The output frequency depends on the timer source and also on the W0F Registers. Indeed, the timer/counter counts from zero up to a value loaded via SW0F registers. Each time the counter is higher or equal to the SW0F shadow registers value, W0C registers are automatically reloaded with zero. If the W0UP bit is set, the shadow SW0F registers are reloaded with the contents of W0F registers when the W0C overtakes. This prevents frequency drift (See Figure 16.).

Note: If the PWMU0 is Off (W0R bit in W0CON not set), the contents of W0FH and W0FL are automatically copied on the shadow registers SW0FH and SW0FL. This allows to charge the correct comparison values in order to have the wanted frequency as soon as the PWM is turned on.

Figure 16. PWMU0 Timer/Counter

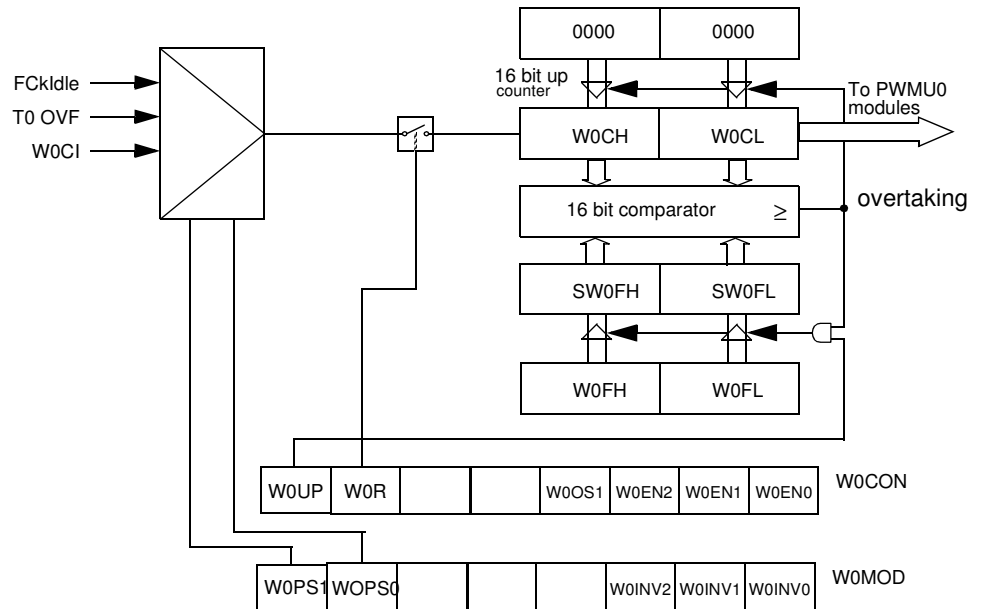

Table 25. W0CON: PWMU0 Control register
W0CON - PWMU0 Control Register (E8h)

7	6	5	4	3	2	1	0
W0UP	W0R	-	-	W0OS	W0EN2	W0EN1	W0EN0
Bit Number	Bit Mnemonic	Description					
7	W0UP	PWMU0 update bit Set by software to request the load of all shadow registers on the next overtaking of the W0C counter. Reset by hardware after the loading of the shadow registers.					
6	W0R	PWMU0 Run control bit Set by software to turn the PWMU0 counter on. Must be cleared by software to turn the PWMU0 counter off.					
5-4	-	Not used					
3	W0OS	Pin W0M1 PWMU0 Output Selection 0 W0M1 is PWM module 1 XOR PWM module2 output 1 W0M1 is PWM module 1 output					
2	W0EN2	PWMU0 Module 2 enable bit Enable PWMU0 module 2 if set.					
1	W0EN1	PWMU0 Module 1 enable bit Enable PWMU0 module 1 if set.					
0	W0EN0	PWMU0 Module 0 enable bit Enable PWMU0 module 0 if set.					

Reset Value = 00XX 0000b

Bit addressable

Table 26. W0MOD: PWMU0 Counter Mode Register
W0MOD - PWMU0 Counter Mode Register (E9h)

	7	6	5	4	3	2	1	0
	W0CPS1	W0CPS0	-	-	-	W0INV2	W0INV1	W0INV0

Bit Number	Bit Mnemonic	Description
7	W0CPS1	PWMU0 Count Pulse Select bit1
6	W0CPS0	PWMU0 Count Pulse Select bit0 CPS1 CPS0 Selected PWMU0 input 00 Internal clock f_{CkIdle} 01 Reserved 10 Timer 0 Overflow 11 External clock input on W0CI at max rate = $f_{CkIdle}/4$
5-3	-	Not used
2	W0INV2	PWMU0 Module 2 inverter bit Select the output PWM mode. If set, PWM module 2 output starts with high level.
1	W0INV1	PWMU0 Module 1 inverter bit Select the output PWM mode. If set, PWM module 1 output starts with high level.
0	W0INV0	PWMU0 Module 0 inverter bit Select the output PWM mode. If set, PWM module 0 output starts with high level.

Reset Value = 00XX X000b

Not bit addressable

Because they use the same timer, all three modules have the same frequency determined by the shadow SW0F registers.

Table 27. W0FH: PWMU0 frequency high control register
W0FH - PWMU0 Frequency Control Register (EAh)

	7	6	5	4	3	2	1	0
	W0F15	W0F14	W0F13	W0F12	W0F11	W0F10	W0F9	W0F8

Bit Number	Bit Mnemonic	Description
7-0	W0F15-8	PWMU0 high bits counter control frequency The PWMU0 counter is counting from zero up to W1F15-0 value.

Reset Value = 1111 1111b

Not bit addressable

Table 28. W0FL: PWMU0 frequency low control register
W0FL - PWMU0 Frequency Control Register (EBh)

7	6	5	4	3	2	1	0
W0F7	W0F6	W0F5	W0F4	W0F3	W0F2	W0F1	W0F0
Bit Number	Bit Mnemonic	Description					
7-0	W0F7-0	PWMU0 low bits counter control frequency The PWMU0 counter is counting from zero up to W0F15-0 value.					

Reset Value = 1111 1111b
Not bit addressable

Table 29. W0CH: PWMU0 counter high control register
W0CH - PWMU0 Counter Control Register (ECh)

7	6	5	4	3	2	1	0
W0C15	W0C14	W0C13	W0C12	W0C11	W0C10	W0C9	W0C8
Bit Number	Bit Mnemonic	Description					
7-0	W0C15-8	PWMU0 high bits counter frequency.					

Reset Value = 0000 0000b
Not bit addressable

Table 30. W0CL: PWMU0 counter low control register
W0CL - PWMU0 Counter Control Register (EDh)

7	6	5	4	3	2	1	0
W0C7	W0C6	W0C5	W0C4	W0C3	W0C2	W0C1	W0C0
Bit Number	Bit Mnemonic	Description					
7-0	W0C7-0	PWMU0 low bits counter frequency.					

Reset Value = 0000 0000b
Not bit addressable

PWMU0 Output Generation

All the PWMU0 modules have the same frequency determined by the W0F register. But each module has its own duty cycle determined by the W0Rn Register. (n is the module number).

When the W0C content is lower than the value programmed via the W0Rn registers, the output is the W0INVn-bit (low if 0, high if 1). When it is equal or higher, the output is the opposite of this W0INVn-bit (high if 0, low if 1).

When the W0C content is higher than SW0F's, an overtaking occurs. The counter value (W0C registers) is automatically reloaded with zero (see Figure 16). If the W0UP bit is high, the new comparison value is reloaded on the shadow SW0R0 registers with the

content of the W0R0 registers (see Figure 16). This method allows to change frequency and duty cycle without glitch.

Note: If the PWMU0 is off (W0R bit in W0CON not set), W0RnH and W0RnL contents are automatically copied on the shadow registers SW0RnH and SW0RnL and the contents of W0FH and W0FL are automatically copied on the shadow registers SW0FH and SW0FL. This allows to charge the correct comparison values for each PWM module as soon as the PWMU0 timer/counter is turned on.

Figure 17. PWMU0 Interrupt System

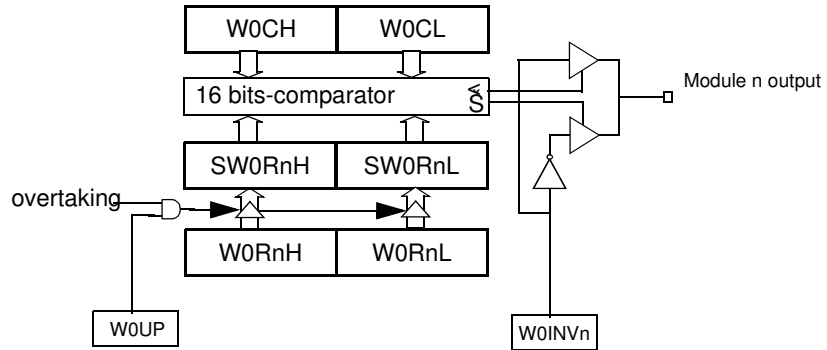

The W0INVn bits that allow output inversion are on the W0MOD (W0 Counter Mode) register (See Table 26.).

Table 31. W0RnH: PWMU0 module n High Toggle Register

W0R0H - PWMU0 Module 0 High Toggle Register (D9h)

W0R1H - PWMU0 Module 1 High Toggle Register (DBh)

W0R2H - PWMU0 Module 2 High Toggle Register (DDh)

	7	6	5	4	3	2	1	0
	W0RnH15	W0RnH14	W0RnH13	W0RnH12	W0RnH11	W0RnH10	W0RnH9	W0RnH8
Bit Number	Bit Mnemonic	Description						
7-0	W0RnH 15-8	PWMU0 Module n high toggle register When the counter exceeds this value, module n output toggles.						

Reset Value = 0000 0000b

Not bit addressable

Table 32. W0RnL: PWMU0 module n Low Toggle Register
 W0R0L - PWMU0 Module 0 Low Toggle Register (DAh)
 W0R1L - PWMU0 Module 1 Low Toggle Register (DCh)
 W0R2H - PWMU0 Module 2 Low Toggle Register (DEh)

7	6	5	4	3	2	1	0
W0RnL7	W0RnL6	W0RnL5	W0RnL4	W0RnL3	W0RnL2	W0RnL1	W0RnL0
Bit Number	Bit Mnemonic	Description					
7-0	W0RnL7-0	PWMU0 Module n low toggle register When the counter exceeds this value, module n output toggles.					

Reset Value = 0000 0000b
 Not bit addressable

PWMU0 Output Selector

In order to generate no recovery signal, it is possible to configure the microcontroller with the W0OC register to have PWMU0 module 1 XOR PWMU0 module 2 on the W0M1 pin (see Figure 18).

Figure 18. .PWMU0 Output Selector

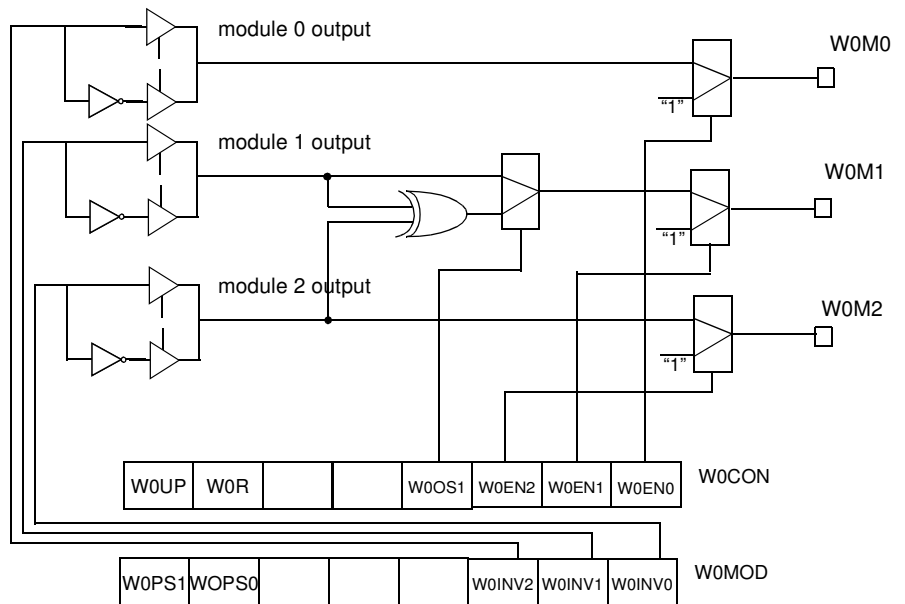

W0CON and W0MOD are detailed on Table 25 and Table 26.

PWMU0 Interrupt System

Each PWMU0 module can generate an interrupt. The W0IC register enables or disables interrupt and interrupt flags (See Table 33).

Figure 19. PWMU0 Interrupt Configuration

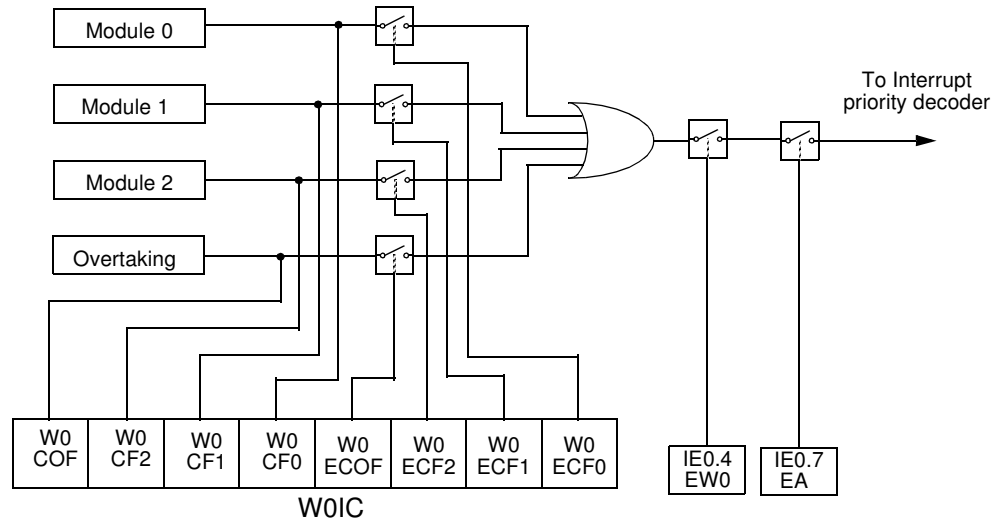

Table 33. PWMU0 interrupt control register
W0IC - PWMU0 Interrupt Control Register (EEh)

7	6	5	4	3	2	1	0
W0CF	W0CF2	W0CF1	W0CF0	W0ECOF	W0ECF2	W0ECF1	W0ECF0
Bit Number	Bit Mnemonic	Description					
7	W0COF	PWMU0 Counter Overtaking Flag Set by hardware when the counter is higher or equal to SW0F's value. CF flags an interrupt if bit W0ECOF is set. W0COF can be set either by hardware or software but can only be cleared by software.					
6	W0CF2	PWMU0 Module 2 Toggle flag Set by hardware when a match occurs. Can also be set by software. Must be cleared by software.					
5	W0CF1	PWMU0 Module 1 Toggle flag Set by hardware when a match occurs. Can also be set by software. Must be cleared by software.					
4	W0CF0	PWMU0 Module 0 Toggle flag Set by hardware when a match occurs. Can also be set by software. Must be cleared by software.					
3	W0ECOF	PWMU0 Counter Overtaking flag Set to Enable IT on PWMU0 Counter Overtaking Flag.					
2	W0ECF2	PWMU0 Module 2 Counter flag Set to enable IT on PWMU0 Module 2 Toggle flag.					
1	W0ECF1	PWMU0 Module 1 Counter flag Set to enable IT on PWMU0 Module 1Toggle flag.					
0	W0ECF0	PWMU0 Module 0 Counter flag Set to enable IT on PWMU0 Module 0Toggle flag.					

Reset Value = 0000 0000b

Not bit addressable

PWM Unit 1 (PWMU1) The PWM unit 1 allows to generate precise pulse width modulation with variable duty cycle and frequency.

The PWMU1 consists of a dedicated 16 bits auto reload counter/timer which serves as a time base for the generation of an independent PWM signal.

Its clock input can be programmed to count any one of the following signals:

- Peripheral clock, CkIdle
- Timer 1 overflow
- External input on W1CI (P4.2)

The PWMU1 timer/counter shares two external I/O. These pins are listed below. If a port is not used for the PWMU1, it can still be used for standard I/O.

PWMU1 Component	External I/O Pin
16-bit Counter	W1CI (P4.2)
16-bit Module 0	W1M0 (P3.5)

PWMU1 Timer

The PWMU1 timer is a 16-bit timer (See Figure 20). The timer count source is determined from the W1CPS1 and W1CPS0 bits in the W1CON register (See Table 34) and can be programmed to run at:

- Peripheral clock, CkIdle
- Timer 1 overflow
- External input on W1CI (P4.2)

The output frequency depends on the timer source and also on the W1F Registers. The timer/counter counts from zero up to a value loaded via SW1F registers. Each time the counter is higher or equal to the SW1F shadow registers value, W1C registers are automatically reloaded with zero. If the W1UP bit is set, the shadow SW1F registers is reloaded with the contents of W1F registers when W1C overtakes. This allows to prevent frequency drift (See Figure 20).

Note: If the PWMU1 is Off (W1R bit in W1CON not set), the contents of W1FH and W1FL are automatically copied on the shadow registers SW1FH and SW1FL. This allows to charge the correct comparison values in order to have the desired frequency as soon as the PWM is turned on.

Figure 20. PWMU1 Timer/Counter

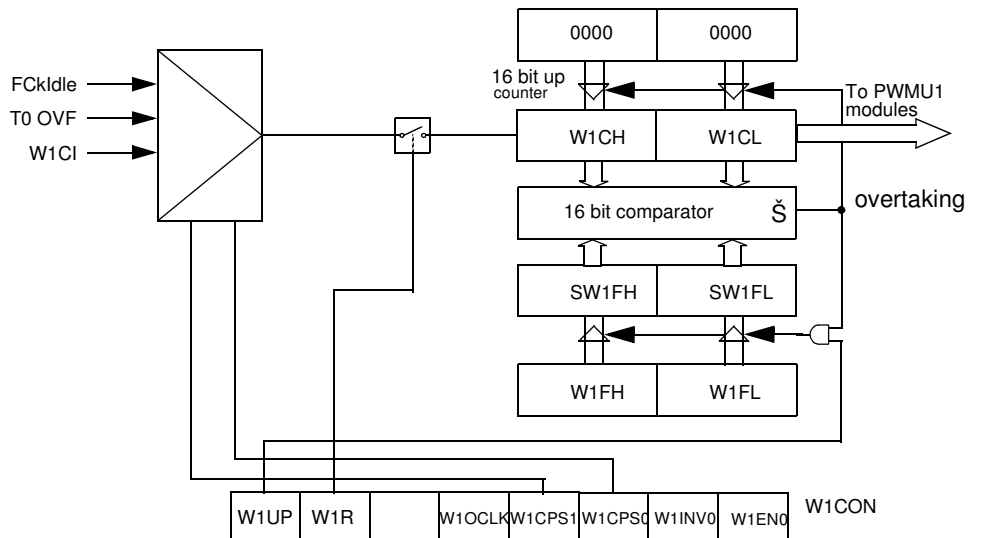

Table 34. W1CON: PWMU1 Control Register
W1CON - PWMU1 Control Register (F8h)

	7	6	5	4	3	2	1	0
	W1UP	W1R	-	W1OCLK	W1CPS1	W1CPS0	W1INV0	W1EN0

Bit Number	Bit Mnemonic	Description
7	W1UP	PWMU1 update bit Set by software to request the load of all shadow registers on the next overtaking of the W1C counter. Reset by hardware after the loading of the shadow registers
6	W1R	PWMU1 Run control bit Set by software to turn the PWMU1 counter on. Must be cleared by software to turn the PWMU1 counter off.
5	-	Not used
4	W1OCLK	Output Clocking Control bit. This bit allows to choose between the output clocking signal and the PWM1M0 output. If set, the external clocking is chosen, if clear, PWM1M0 is chosen.
3	W1CPS1	PWMU1 Count Pulse Select bit1
2	W1CPS0	PWMU Count Pulse Select bit0 CPS1 CPS0 Selected PWMU1 input 00 Internal clock f_{Ckidle} 01 Reserved 10 Timer 1 Overflow 11 External clock input on W1CI at max rate = $f_{Ckidle}/4$
1	W1INV0	PWMU1 Module 0 inverter bit Select the output PWM mode. If set, PWM module 0 output starts with high level.
0	W1EN0	PWMU1 Module 0 enable bit Enable PWMU1 module 0 if set. If clear, P3.5 is an I/O port.

Reset Value = 000'RST_OCLK' 000'RST_OCLK'b
Bit addressable

Table 35. W1FH: PWMU1 frequency high control register
W1FH - PWMU1 Frequency Control Register (FAh)

	7	6	5	4	3	2	1	0
	W1F15	W1F14	W1F13	W1F12	W1F11	W1F10	W1F9	W1F8

Bit Number	Bit Mnemonic	Description
7-0	W1F15-8	PWMU1 high bits counter control frequency The PWMU1 counter is counting from zero up to W1F15-0 value.

Reset Value = 1111 1111b
Not bit addressable

Table 36. W1FL: PWMU1 frequency low control register
W1FL - PWMU1 Frequency Control Register (FBh)

7	6	5	4	3	2	1	0
W1F7	W1F6	W1F5	W1F4	W1F3	W1F2	W1F1	W1F0
Bit Number	Bit Mnemonic	Description					
7-0	W1F7-0	PWMU1 low bits counter control frequency The PWMU1 counter is counting from zero up to W1F15-0 value.					

Reset Value = 1111 1111b
Not bit addressable

Table 37. W1CH: PWMU1 counter high control register
W1CH - PWMU1 Counter Control Register (FCh)

7	6	5	4	3	2	1	0
W1C15	W1C14	W1C13	W1C12	W1C11	W1C10	W1C9	W1C8
Bit Number	Bit Mnemonic	Description					
7-0	W1C15-8	PWMU1 high bits counter frequency					

Reset Value = 0000 0000b
Not bit addressable

Table 38. W1CL: PWMU1 counter low control register
W1CL - PWMU1 Counter Control Register (FDh)

7	6	5	4	3	2	1	0
W1C7	W1C6	W1C5	W1C4	W1C3	W1C2	W1C1	W1C0
Bit Number	Bit Mnemonic	Description					
7-0	W1F7-0	PWMU1 low bits counter frequency					

Reset Value = 0000 0000b
Not bit addressable

PWMU1 Output Generation

All the PWMU1 modules have the same frequency determined by the W1F registers. However, each module has its own duty cycle determined by the W1Rn Registers. (n is the module number).

When the W1C content is lower than the value programmed via W1Rn registers, the output is the W1INVn-bit (low if 0, high if 1). When it is equal or higher, the output is the opposite of this W1INVn-bit (high if 0, low if 1).

When the W1C content is higher than SW1F's, an overtaking occurs. The counter value (W1C registers) is automatically reloaded with zero (see Figure 21.). If the W1UP bit is high, the new comparison value is reloaded on the shadow SW1R0 registers with the

content of the W1R0 registers (see Figure 21.). This method allows to change frequency and duty cycle without glitch.

Note: If the PWMU1 is Off (W1R bit in W0CON not set), W1RnH and W1RnL contents are automatically copied on the shadow registers SW1RnH and SW1RnLn and the contents of W1FH and W1FL are automatically copied on the shadow registers SW1FH and SW1FL. This allows to charge the correct comparison values for each PWM module as soon as the PWMU1 timer/counter is turned on.

Figure 21. PWMU1 Interrupt System

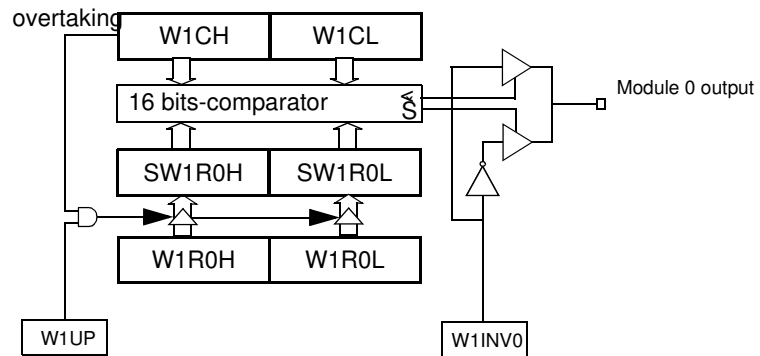

The W1INV0 bit that allows output inversion is on the W1CON (W1 Control) register (See Table 34.).

Table 39. W1R0H: PWMU1 module 0 High Toggle Register
W1R0H - PWMU1 Module 0 High Toggle Register (C9h)

7	6	5	4	3	2	1	0
W1R0H15	W1R0H14	W1R0H13	W1R0H12	W1R0H11	W1R0H10	W1R0H9	W1R0H8
Bit Number	Bit Mnemonic	Description					
7-0	W1R0H 15-8	PWMU1 Module 0 high toggle register When the counter exceeds this value, module 0 output toggles.					

Reset Value = 0000 0000b

Not bit addressable

Table 40. W1R0L: PWMU1 module 0 Low Toggle Register
W1R0L - PWMU1 Module 0 Low Toggle Register (CAh)

7	6	5	4	3	2	1	0
W1R0L7	W1R0L6	W1R0L5	W1R0L4	W1R0L3	W1R0L2	W1R0L1	W1R0L0
Bit Number	Bit Mnemonic	Description					
7-0	W1R0L7-0	PWMU1 Module 0 low toggle register When the counter exceeds this value, module 0 output toggles.					

Reset Value = 0000 0000b

Not bit addressable

PWMU1 Output Selector

As shown on Figure 22., the PWMU1 can configure P3.5 to be used as

- The PWMU1 module 0 output (W1R = 1 and W1EN0 = 1)
- The External Clocking output (W1OCLK = 1 and W1EN0 = 1)
- An I/O port (W1EN0 = 0)

This configuration is made via W1CON register (See Table 34.). By default, W1CON register contains 00h. So P3.5 is configured as an I/O port.

The W1INV0 bit allows to start PWMU1 module 0 period with a high (if set) or low level.

Figure 22. PWMU1 Output Selector

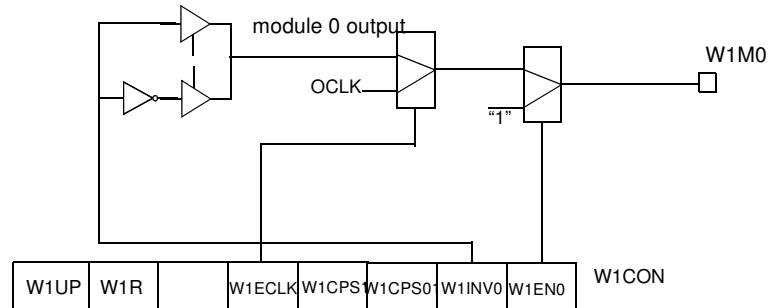

PWMU1 Interrupt System

PWMU1 can generate an interrupt. The W1IC register enables or disables interrupt and interrupt flags (See Table 41).

Figure 23. PWMU1 Interrupt Configuration

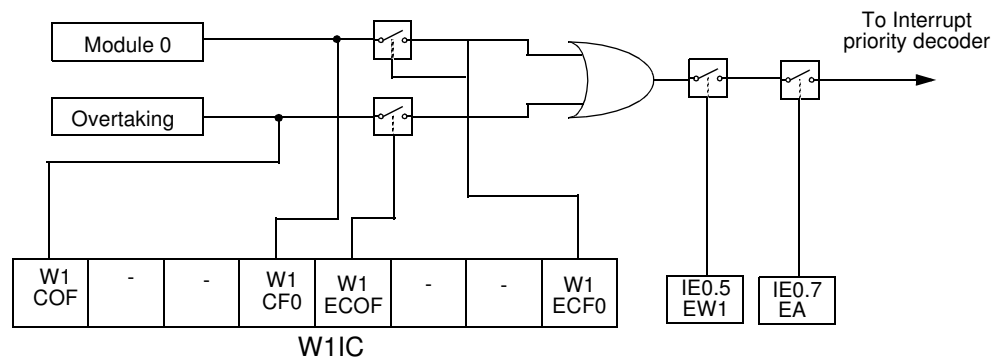

Table 41. PWMU1 Interrupt Control Register
W1IC - PWMU1 Interrupt Control Register (FEh)

7	6	5	4	3	2	1	0
W1CF	-	-	W1CF0	W1ECF	-	-	W1ECF0

Bit Number	Bit Mnemonic	Description
7	W1COF	PWMU1 Counter Overtaking Flag Set by hardware when the counter rolls over. CF flags an interrupt if bit W1ECOF is set. W1COF can be set either by hardware or software but can only be cleared by software.
6-5	-	Not used
4	W1CF0	PWMU1 Module 0 Toggle fla Set by hardware when a match occurs. Can also be set by software. Must be cleared by software.
3	W1ECOF	PWMU1 Counter Overtaking Flag Set to Enable PWMU1 Counter Overtaking Flag.
2-1	-	Not used
0	W1ECF0	PWMU1 Module 0 Counter flag Set to enable PWMU1 Module 0Toggle flag.

Reset Value = 0000 0000b
Not bit addressable

WatchDog Timer

AT8xEB5114 contains a powerful programmable hardware WatchDog Timer (WDT) that automatically resets the chip if its software fails to reset the WDT before the selected time interval has elapsed. It permits large Time-Out ranking from 16 ms to 2s @Fosc = 12 MHz.

This WDT consists of a 14-bit counter plus a 7-bit programmable counter, a WatchDog Timer reset register (WDTRST) and a WatchDog Timer programming (WDTPRG) register. When exiting reset, the WDT is -by default- disabled. To enable the WDT, the user has to write the sequence 1EH and E1H into WDRST register. When the WatchDog Timer is enabled, it will increment every machine cycle while the oscillator is running and there is no way to disable the WDT except through reset (either hardware reset or WDT overflow reset). When WDT overflows, it will generate an output RESET pulse at the RST pin. The RESET pulse duration is $96 \times T_{OSC}$, where $T_{OSC} = 1/F_{OSC}$. To make the best use of the WDT, it should be serviced in those sections of code that will periodically be executed within the time required to prevent a WDT reset.

The WDT is controlled by two registers (WDTRST and WDTPRG)

Figure 24. WatchDog Timer

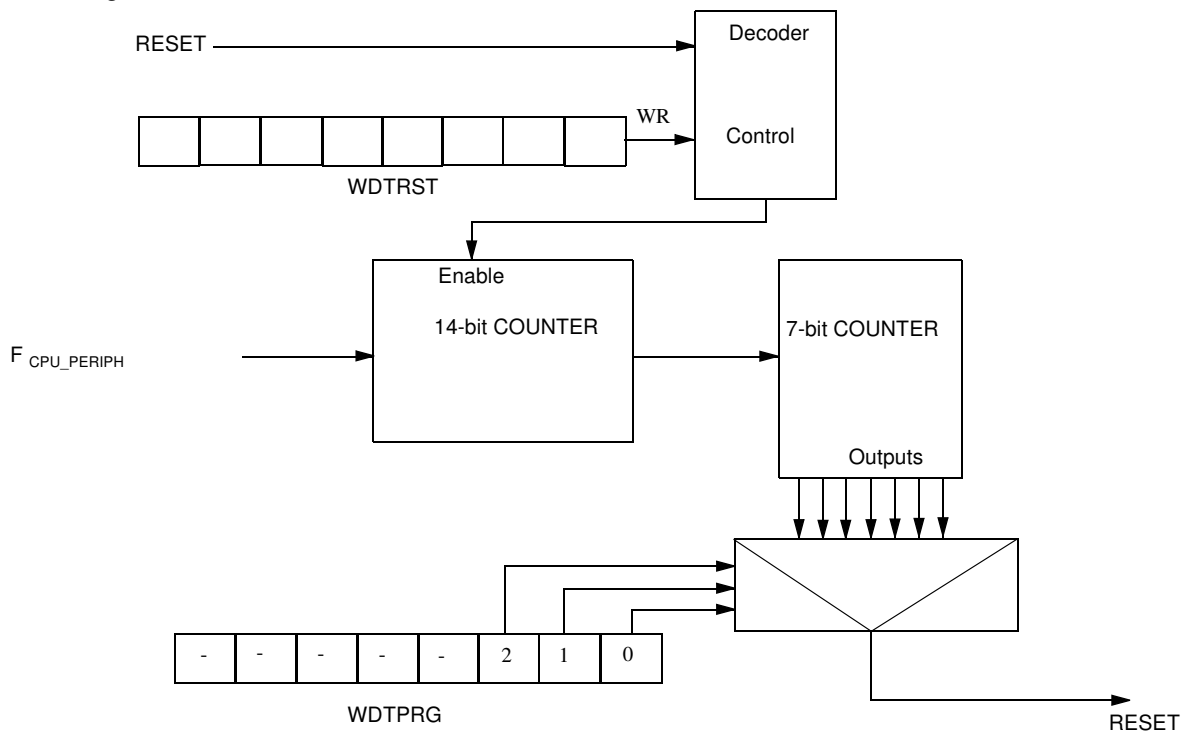

Figure 25. WDTPRG Register
 WDTPRG - WatchDog Timer Duration Programming register (A7h).

Bit Number	Bit Mnemonic	Description
7	-	Reserved The value read from this bit is indeterminate. Do not set this bit.
6	-	Reserved The value read from this bit is indeterminate. Do not set this bit.
5	-	Reserved The value read from this bit is indeterminate. Do not set this bit.
4	-	Reserved The value read from this bit is indeterminate. Do not set this bit.
3	-	Reserved The value read from this bit is indeterminate. Do not set this bit.
2	S2	WatchDog Timer Duration selection bit 2 Work in conjunction with bit 1 and bit 0.
1	S1	WatchDog Timer Duration selection bit 1 Work in conjunction with bit 2 and bit 0.
0	S0	WatchDog Timer Duration selection bit 0 Work in conjunction with bit 1 and bit 2.

Reset Value = XXXX X000b

The three lower bits (S0, S1, S2) located into WDTPRG register permit to program the WDT duration.

S2	S1	S0	Machine Cycle Count
0	0	0	2 ¹⁴ - 1
0	0	1	2 ¹⁵ - 1
0	1	0	2 ¹⁶ - 1
0	1	1	2 ¹⁷ - 1
1	0	0	2 ¹⁸ - 1
1	0	1	2 ¹⁹ - 1
1	1	0	2 ²⁰ - 1
1	1	1	2 ²¹ - 1

To compute WD Time-Out, the following formula is applied:

$$TimeOut = \frac{((FclkPeriph)^{x2})^{x2}}{12 \times ((2^{14} \times 2^{Svalue}) - 1) \times (15 - CKRL)}$$

Note: Note: Value represents the decimal value of (S2 S1 S0) / CKRL represents the Prescaler

Find Hereafter computed Time-Out value for Fosc = 12 MHz

Table 42. Time-Out Computation @12 MHz

S2	S1	S0	Time-Out for F _{osc} =12 MHz
0	0	0	16.38 ms
0	0	1	32.77 ms
0	1	0	65.54 ms
0	1	1	131.07 ms
1	0	0	262.14 ms
1	0	1	524.29 ms
1	1	0	1.05 s
1	1	1	2.10 s

Table 43. WDTRST Register

7	6	5	4	3	2	1	0
-	-	-	-	-	-	-	-

Reset Value = XXXX XXXXb

The WDTRST register is used to reset/enable the WDT by writing 1EH then E1H in sequence.

WatchDog Timer During Power Down Mode and Idle

In Power Down mode the oscillator stops, which means the WDT also stops. While in Power Down mode the user does not need to service the WDT. There are 2 methods of exiting Power Down mode: by a hardware reset or via a level activated external interrupt which is enabled prior to entering Power Down mode. When Power Down is exited with hardware reset, servicing the WDT should occur as it normally does whenever AT8xEB5114 is reset. Exiting Power Down with an interrupt is significantly different. The interrupt is held low long enough for the oscillator to stabilize. When the interrupt is brought high, the interrupt is serviced. To prevent the WDT from resetting the device while the interrupt pin is held low, the WDT is not started until the interrupt is pulled high. It is suggested that the WDT be reset during the interrupt service for the interrupt used to exit Power Down.

To ensure that the WDT does not overflow within a few states of exiting of power down, it is best to reset the WDT just before entering power down.

In the Idle mode, the oscillator continues to run. To prevent the WDT from resetting while in Idle mode, the user should always set up a timer that will periodically exit Idle, service the WDT, and re-enter Idle mode.

Analog-to-Digital Converter (ADC)

This section describes the on-chip 10 bit analog-to-digital converter of the AT8xEB5114. Six ADC channels are available for sampling of the external sources AIN0 to AIN5. An analog multiplexer allows the single ADC converter to select one from the 6 ADC channels as ADC input voltage (ADCIN). ADCIN is converted by the 10 bit-cascaded potentiometric ADC.

8 to 10 bits resolution can only be reached while using an external voltage reference.

For the precision conversion, set bits PSIDLE and ADSST in ADCON register to start the conversion. The chip is in a pseudo-idle mode, the CPU doesn't run but the peripherals are always running. This mode allows digital noise to be lower, to ensure precise conversion.

For accurate conversion, set bits QUIETM and ADSST in ADCON register to start the conversion. The chip is in a quiet mode, the AD is the only peripheral running. This mode allows digital noise to be as low as possible, to ensure high precision conversion.

For these modes it is necessary to work with end of conversion interrupt, which is the only way to wake up the chip.

If another interrupt occurs during the precision conversion, it will be treated only after this conversion is ended.

Features

- 6 channels with multiplexed inputs
- One channel with input signal average extraction and programmable gain amplification.
- 10-bit cascaded potentiometric ADC
- Typical conversion time 20 micro-seconds
- Zero Error (offset) +/- 2 LSB max
- External Positive Reference Voltage Range 2.4 to V_{CC}
- Internal Positive Reference typical Voltage 2.4 Volt ⁽¹⁾
- ADCIN Range 0 to V_{REF}
- Integral non-linearity typical 1 LSB ⁽¹⁾
- Differential non-linearity typical 0.5 LSB ⁽¹⁾
- Conversion Complete Flag or Conversion Complete Interrupt
- Selected ADC Clock

Note: (1): See "DC Parameters for A/D Converter" on page 88.

ADC I/O Functions

AINx are general I/O that are shared with the ADC channels. The channel select bit in ADCF register define which ADC channel pin will be used as ADCIN. The remaining ADC channels pins can be used as general purpose I/O or as the alternate function that is available. Writings to the port registers which aren't selected by the ADCF will not have any effect.

Figure 26. ADC Description

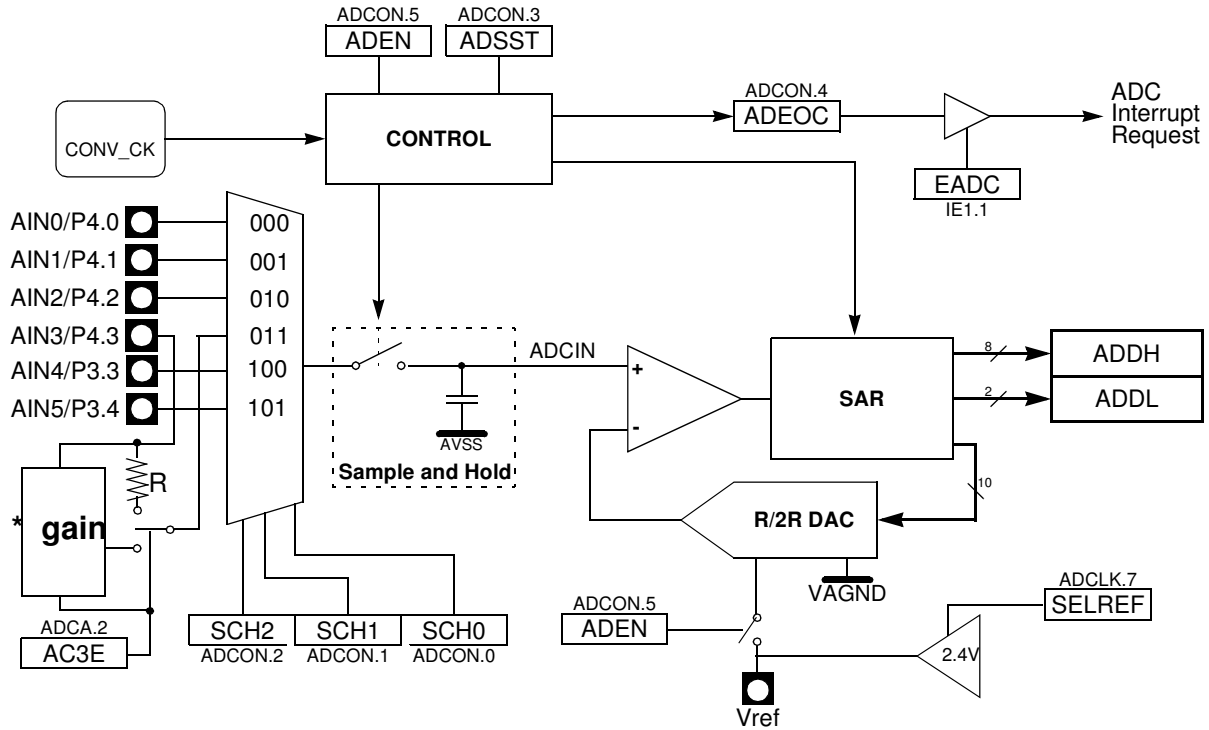
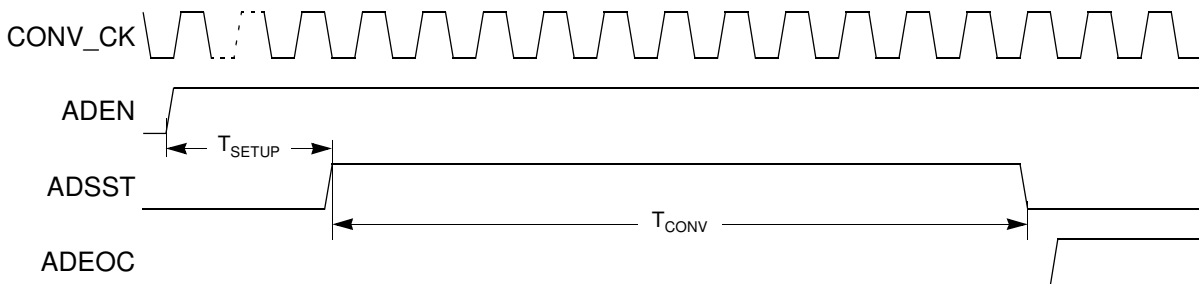

Figure 27 shows the timing diagram of a complete conversion. For simplicity, the figure depicts the waveforms in idealized form and do not provide precise timing information. For ADC characteristics and timing parameters refer to the Section “DC Parameters for A/D Converter”, page 88.

Figure 27. Timing Diagram



Note: $T_{setup} = 0 \text{ CLK}$

Channel 3 Amplifier and Rectifying Function

If needed, the average value of the rectified signal on channel 3 can be extracted and amplified before A/D conversion as shown on Figure 28.

Figure 28. Channel 3 Amplifier

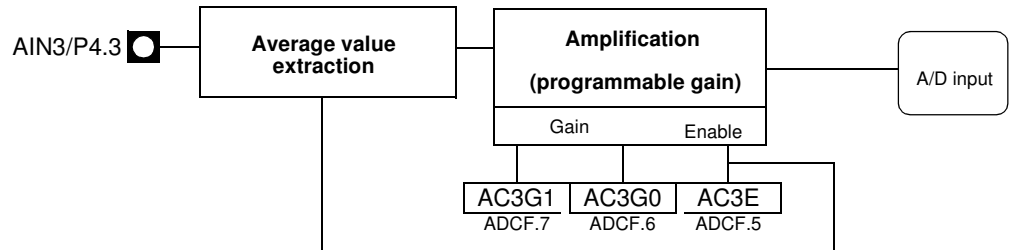

The main characteristics of this block are the following:

- Input signal level: sine wave centered around V_{ssa} , peak value from 70 to 550 mV depending on gain, Frequency range from 35 to 70KHz. Be sure that the peak value on the amplifier output is lower than voltage supply.
- Gain: x5, x10, x15 and x20, selected using AC3E, AC3G1 and AC3G0 in ADC Amplifier register (See Table 44 and Table 52)
- Max time constant of the average value extraction: 0.5ms. When the gain is changed or when the signal levels changes from the minimum to the maximum value, a new measurement can be done after 10 time constant.
- The amplifier needs 20us to fully load the ADC hold capacitance so the ADC conversion must occurs at least 20us after the amplified channel is sampled.
- Accuracy on amplification and extraction: +/- 5%

Note: The AIN3 direct channel is not equivalent to the other channels. There is a serial resistance of around 100KΩ between the pin and the ADC input. So when the amplifier is bypassed, it is necessary to switch at least 20us the mux on AIN3 input before starting a conversion.

Table 44. ADCF Register

ADCA (S:F7h)
ADC Amplifier Configuration

7	6	5	4	3	2	1	0
-	-	-	-	-	AC3E	AC3G1	AC3G0
Bit Number	Bit Mnemonic	Description					
7-3	-	Not used					
2	AC3E	Enable Channel 3 amplifier Set to enable amplifier. Clear for Standby mode					
1	AC3G1	Channel 3 amplifier gain					
0	AC3G0	AC3G1	AC3G0				
		0	0	gain x5			
		0	1	gain x10			
		1	0	gain x15			
		1	1	gain x20			

Reset Value = 0000 0000b

ADC Converter Operation

A start of single A/D conversion is triggered by setting bit ADSST (ADCON.3).

The busy flag ADSST(ADCON.3) remains set as long as an A/D conversion is running. After completion of the A/D conversion, it is cleared by hardware. When a conversion is running, this flag can be read only, a write has no effect.

The end-of-conversion flag ADEOC (ADCON.4) is set when the value of conversion is available in ADDH and ADDL, it is cleared by software. If the bit EADC (IE0.6) is set, an interrupt occur when flag ADEOC is set (see Figure 30). Clear this flag for re-arming the interrupt.

The bits SCH0 to SCH2 in ADCON register are used for the analog input channel selection.

Before starting normal power reduction modes the ADC conversion has to be completed.

Table 45. Selected Analog Input

SCH2	SCH1	SCH0	Selected Analog input
0	0	0	AN0
0	0	1	AN1
0	1	0	AN2
0	1	1	AN3
1	0	0	AN4
1	0	1	AN5
1	1	0	
1	1	1	

Voltage Conversion

When the ADCIN is equal to VAREF the ADC converts the signal to 3FFh (full scale). If the input voltage equals VAGND, the ADC converts it to 000h. Input voltage between VAREF and VAGND are a straight-line linear conversion. All other voltages will result in 3FFh if greater than VAREF and 000h if less than VAGND.

Note that ADCIN should not exceed VAREF absolute maximum range.

Clock Selection

The maximum clock frequency for ADC (CONV_CK for Conversion Clock) is defined in the Section “AC Parameters”, page 88. A prescaler is featured to generate the CONV_CK clock from the oscillator frequency. The prescaler value PRS[6:0] is defined in the ADCLK register (see Table 49 on page 64)

Figure 29. A/D Converter clock

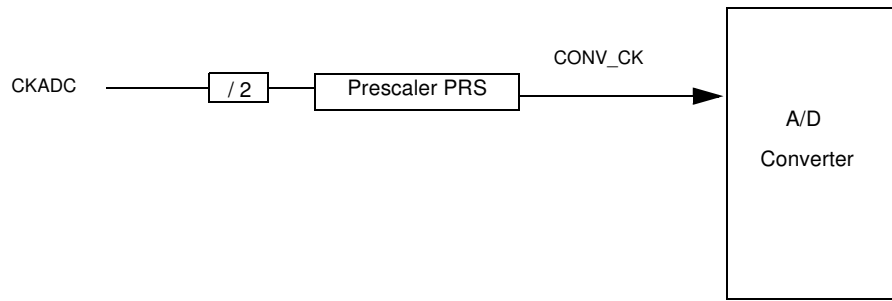

The conversion frequency CONV_CK is derived from the oscillator frequency with the following formulas:

$$F_{CkAdc} = F_{OscOut} / (32 - 2 * CKRL), \text{ if } X2=0$$

$$= F_{OscOut}, \text{ if } X2=1$$

and

$$F_{CONV_CK} = F_{CkAdc} / (2 * PRS), \text{ if } PRS > 0$$

$$F_{CONV_CK} = F_{CkAdc} / 256, \text{ if } PRS = 0$$

Some examples can be found on table below:

F _{OscOut} MHz	X2	CKRL	F _{CkAdc} Mhz	PRSw	F _{CONV_CK} khz	Conversion time μs
16	0	F	8	12	333	33
16	1	NA	16	32	250	44

ADC Standby Mode

When the ADC is not used, it is possible to set it in standby mode by clearing bit ADEN in ADCON register.

Voltage Reference

The voltage reference can be either internal or external.

As input, the V_{REF} pin is used to enter the voltage reference for the A/D conversion.

When the voltage reference is active, the V_{REF} pin is an output. This voltage can be used for the A/D and for any other application requiring a voltage independent from the power supply. Voltage typical value is 2.4 volt (See “DC Parameters for A/D Converter” on page 88.)

IT ADC Management

An interrupt end-of-conversion will occur when the bit ADEOC is activated and the bit EADC is set. For re-arming the interrupt the bit ADEOC must be cleared by software.

Figure 30. ADC Interrupt Structure

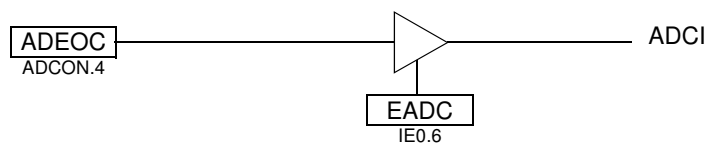

Accuracy improvement on analog to digital conversion using the internal voltage reference

Overview

The internal Vref absolute accuracy is around 4%. This variation is mainly due to the temperature, the process, and the voltage variations. In order to increase the accuracy of the measurements made thanks to the ADC, it is possible to make a software correction of the Vref, in order to calculate the result the ADC should have returned in case the Vref was more accurate.

The idea of this improvement is the following: Because there is an EEPROM stacked on the product, it is possible to store a linear coefficient which allow a correction of the process variations.

Coefficient address

The coefficient is stored at the address 0x00 of the serial data EEPROM stacked on the AT8xEB5114.

Coefficient format

In order to ease the calculation, this coefficient has been stored as a floating decimal number corresponding to Table 46.

Table 46. Calibration coefficient storage format

Bit	Value
7	1,
6	1/2
5	1/4
4	1/8
3	1/16
2	1/32
1	1/64
0	1/128

It means that if the value is 0x80, the coefficient is equal to 1. If the coefficient is 0x7e, the coefficient is equal to 0,111 1110 in binary which is 0,983 in decimal.

During the test, the Vref is measured, and the calibration value calculated is stored at the address 0x00 of the stack die in accordance with the Table 46 format value.

The relation between the coefficient stored, and the true Vref measurement are recorded on the Table 47.

Table 47. Relation between True Vref measurement and coefficient stored into the EEPROM

True Vref	Min	2.300	2.316	2.334	2.353	2.372	2.391	2.409	2.428	2.447	2.466	2.484
Value (V)	Typ	2.306	2.325	2.345	2.362	2.381	2.400	2.419	2.438	2.456	2.475	2.494
	Max	2.316	2.334	2.353	2.372	2.391	2.409	2.428	2.447	2.466	2.484	2.500
Value stored		0x7b	0x7c	0x7d	0x7e	0x7f	0x80	0x81	0x82	0x83	0x84	0x85
decimal value		0.961	0.969	0.977	0.984	0.992	1	1.008	1.016	1.023	1.031	1.039

How to Take Advantage of the Calibration Value

The coefficient stored on the stacked die allow to determine the conversion result the AT8xEB51 14 should have returned in case its Vref was exactly equal to 2.4V. In order to determine it, a multiplication of the result of the conversion with the coefficient stored in the stack, followed by a shift are sufficient.

Example

Vref is 2.36V instead of 2.4V, and only 8 bits are necessary.

The value measured during the test 2.36V. So, in accordance with the Table 47, the coefficient which has to be stored on the EEPROM is 0x7e which corresponds to 0.1111110 in binary, which also corresponds to around 2.36/2.4.

If, for example, after a conversion, the ADDH register contains 0xf0, to know the result the ADC should have returned in case the Vref was really at 2.4V, the following operations are necessary:

$$0xf0 * 0x7e = 1111\ 0000 * 0111\ 1110 = 0x7620 = 0111\ 0110\ 0010\ 0000.$$

So because of the point on the coefficient, the result is 1110 110 which is 0xec.

Assembler code example

This is an example of assembler code optimized for size and fast recalculation in case 8 bits are sufficient.

```

start_adjustement : MOV  B,coeff ; Coeff
                   MOV  A,ADDH  ; ADC result
                   MUL  AB      ;
                   RLC  A       ; Recover lowest bit
                   MOV  A,B     ;
                   RLC  A       ; Recover result
                   JNC  end_fix  ; Result OK
                   MOV  A,#0ffh ; Overflow
end_adjustement   : RET
    
```

The new result is stored on the accumulator.

This routine requires 15 bytes + 3 bytes for the long call (LCALL).

The execution of the subroutine (including the LCALL) is 18 cycles in normal case and 19 cycles in case of overflow (less than 10us with a 12 MHz oscillator and the X2 mode).

Registers

Table 48. ADCON Register

ADCON (S:F3h)
ADC Control Register

7	6	5	4	3	2	1	0
QUIETM	PSIDLE	ADEN	ADEOC	ADSST	SCH2	SCH1	SCH0
Bit Number	Bit Mnemonic	Description					
7	QUIETM	Quiet mode (best precision) Set to put in quiet mode during conversion. Cleared by hardware after completion of the conversion.					
6	PSIDLE	Pseudo Idle mode (good precision) Set to put in idle mode during conversion. Cleared by hardware after completion of the conversion.					



Bit Number	Bit Mnemonic	Description
5	ADEN	Enable/Standby Mode Set to enable ADC. Clear for Standby mode.
4	ADEOC	End Of Conversion Set by hardware when ADC result is ready to be read. This flag can generate an interrupt. Must be cleared by software.
3	ADSST	Start and Status Set to start an A/D conversion. Cleared by hardware after completion of the conversion.
2-0	SCH2:0	Selection of channel to convert see Table 45 on page 60.

Reset Value = X000 0000b

Table 49. ADCLK Register

ADCLK (S:F2h)

ADC Clock PrescalerSC

7	6	5	4	3	2	1	0	
SELREF	PRS 6	PRS 5	PRS 4	PRS 3	PRS 2	PRS 1	PRS 0	
Bit Number	Bit Mnemonic	Description						
7	SELREF	Selection and activation of the internal 2.4V voltage reference Set to enable the internal voltage reference. Clear to disable the internal voltage reference.						
6-0	PRS6:0	Clock Prescaler $f_{\text{CONV_CK}} = f_{\text{CKADC}} / (2 * \text{PRS})$ if PRS=0, $f_{\text{CONV_CK}} = f_{\text{CKADC}} / 256$						

Reset Value = 0000 0000b

Table 50. ADDH Register

ADDH (S:F5h Read Only)

ADC Data High byte register

7	6	5	4	3	2	1	0	
ADAT 9	ADAT 8	ADAT 7	ADAT 6	ADAT 5	ADAT 4	ADAT 3	ADAT 2	
Bit Number	Bit Mnemonic	Description						
7-0	ADAT9:2	ADC result bits 9-2						

Read only register

Reset Value = 00h

Table 51. ADDL Register
 ADDL (S:F4h Read Only)
 ADC Data Low byte register

7	6	5	4	3	2	1	0
-	-	-	-	-	-	ADAT 1	ADAT 0

Bit Number	Bit Mnemonic	Description
7-6	-	Reserved The value read from these bits are indeterminate. Do not set these bits.
1-0	ADAT1:0	ADC result bits 1-0

Read only register

Reset Value = xxxx xx00b

Table 52. ADCF Register
ADCF (S:F6h)
ADC Configuration

7	6	5	4	3	2	1	0
-	-	CH5	CH4	CH3	CH2	CH1	CH0
Bit Number	Bit Mnemonic	Description					
7-6	-	Not used					
5	CH5	Channel Configuration Set to use P3.4 as ADC input Clear to use P3.4 as an other function					
4	CH4	Channel Configuration Set to use P3.3 as ADC input Clear to use P3.3 as an other function					
3-0	CH3-0	Channel Configuration Set to use P4.x as ADC input Clear to use P4.x as an other function					

Reset Value = 0000 0000b

Interrupt System

The AT8xEB5114 has a total of 8 interrupt vectors: two external interrupts ($\overline{INT0}$ and $\overline{INT1}$), two timer interrupts (timers 0, 1), serial port interrupt, PWMU0, PWMU1 and A/D. These interrupts are shown in Figure 31.

Figure 31. Interrupt Control System

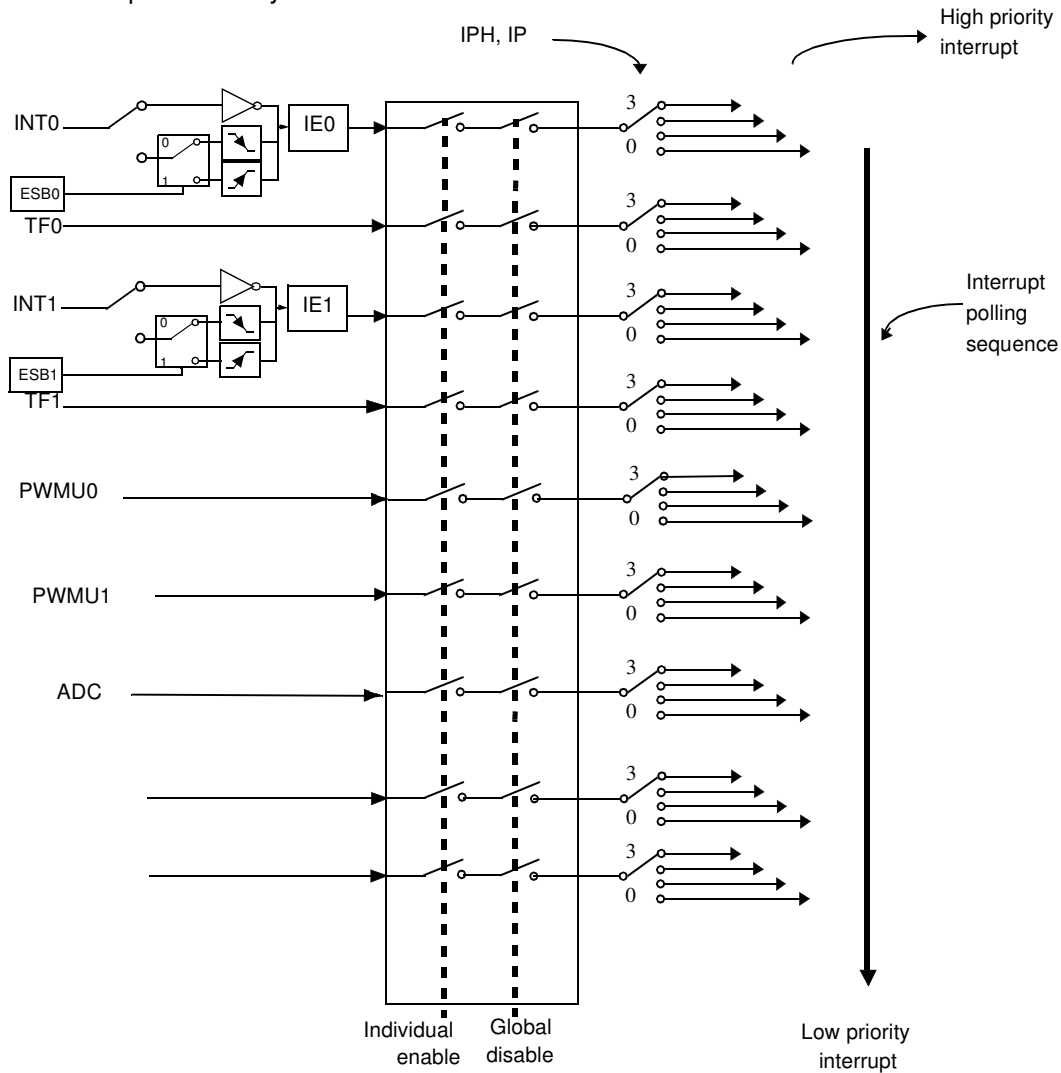

Each of the interrupt sources can be individually enabled or disabled by setting or clearing a bit in the Interrupt Enable register (See Table 54). This register also contains a global disable bit, which must be cleared to disable all interrupts simultaneously.

Each interrupt source can also be individually programmed to one of four priority levels by setting or clearing a bit in the Interrupt Priority register (See Table 55) and in the Interrupt Priority High register (See Table 56). Table 53 shows the bit values and priority levels associated with each combination.

Table 53. Priority Bit Level Values

IPH.x	IP.x	Interrupt Level Priority
0	0	0 (Lowest)
0	1	1
1	0	2
1	1	3 (Highest)

A low-priority interrupt can be interrupted by a high priority interrupt, but not by another low-priority interrupt. A high-priority interrupt can't be interrupted by any other interrupt source.

If two interrupt requests of different priority levels are received simultaneously, the request of higher priority level is serviced. If interrupt requests of the same priority level are received simultaneously, an internal polling sequence determines which request is serviced. Thus within each priority level there is a second priority structure determined by the polling sequence.

Interrupt Name	Interrupt Address Vector	Priority Number
external interrupt (INT0)	0003h	1
Timer0 (TF0)	000Bh	2
external interrupt (INT1)	0013h	3
Timer1 (TF1)	001Bh	4
PWM0	0023h	5
PWM1	002Bh	6
ADC	0033h	7

Table 54. IEN0 Register
IEN0 - Interrupt Enable Register (A8h)

7	6	5	4	3	2	1	0
EA	EADC	EW1	EW0	ET1	EX1	ET0	EX0
Bit Number	Bit Mnemonic	Description					
7	EA	Enable All interrupt bit Clear to disable all interrupts. Set to enable all interrupts. If EA=1, each interrupt source is individually enabled or disabled by setting or clearing its interrupt enable bit.					
6	EADC	ADC Interrupt Enable Clear to disable the ADC interrupt. Set to enable the ADC interrupt.					
5	EW1	PWM1 Enable bit Clear to disable PWMU interrupt. Set to enable PWMU port interrupt.					
4	EW0	PWM0 Enable bit Clear to disable PWMU interrupt. Set to enable PWMU port interrupt.					
3	ET1	Timer 1 overflow interrupt Enable bit Clear to disable timer 1 overflow interrupt. Set to enable timer 1 overflow interrupt.					
2	EX1	External interrupt 1 Enable bit Clear to disable external interrupt 1. Set to enable external interrupt 1.					
1	ET0	Timer 0 overflow interrupt Enable bit Clear to disable timer 0 overflow interrupt. Set to enable timer 0 overflow interrupt.					
0	EX0	External interrupt 0 Enable bit Clear to disable external interrupt 0. Set to enable external interrupt 0.					

Reset Value = 0000 0000b
Bit addressable

Table 55. IPL0 Register
IPL0 - Interrupt Priority Register (B8h)

7	6	5	4	3	2	1	0
-	PADC	PW1	PW0	PT1	PX1	PT0	PX0

Bit Number	Bit Mnemonic	Description
7	-	Reserved The value read from this bit is indeterminate. Do not set this bit.
6	PADC	ADC interrupt Priority bit Refer to PADCH for priority level
5	PW1	PWMU1 Priority bit Refer to PW1H for priority level.
4	PW1	PWMU0 Priority bit Refer to PW1H for priority level.
3	PT1	Timer 1 overflow interrupt Priority bit Refer to PT1H for priority level.
2	PX1	External interrupt 1 Priority bit Refer to PX1H for priority level.
1	PT0	Timer 0 overflow interrupt Priority bit Refer to PT0H for priority level.
0	PX0	External interrupt 0 Priority bit Refer to PX0H for priority level.

Reset Value = X000 0000b
Bit addressable.

Table 56. IPH0 Register
IPH0 - Interrupt Priority High Register (B7h)

7	6	5	4	3	2	1	0
-	PADCH	PW1H	PW0H	PT1H	PX1H	PT0H	PX0H
Bit Number	Bit Mnemonic	Description					
7	-	Reserved The value read from this bit is indeterminate. Do not set this bit.					
6	PADCH	ADC Interrupt Priority level most significant bit <u>PADCH</u> <u>PADC</u> <u>Priority Level</u> 0 0 Lowest 0 1 1 0 1 1 Highest					
5	PW1H	PWMU1 Priority High bit <u>PW1H</u> <u>PW1</u> <u>Priority Level</u> 0 0 Lowest 0 1 1 0 1 1 Highest					
4	PW1H	PWMU0 Priority High bit <u>PW1H</u> <u>PW1</u> <u>Priority Level</u> 0 0 Lowest 0 1 1 0 1 1 Highest					
3	PT1H	Timer 1 overflow interrupt Priority High bit <u>PT1H</u> <u>PT1</u> <u>Priority Level</u> 0 0 Lowest 0 1 1 0 1 1 Highest					
2	PX1H	External interrupt 1 Priority High bit <u>PX1H</u> <u>PX1</u> <u>Priority Level</u> 0 0 Lowest 0 1 1 0 1 1 Highest					
1	PT0H	Timer 0 overflow interrupt Priority High bit <u>PT0H</u> <u>PT0</u> <u>Priority Level</u> 0 0 Lowest 0 1 1 0 1 1 Highest					
0	PX0H	External interrupt 0 Priority High bit <u>PX0H</u> <u>PX0</u> <u>Priority Level</u> 0 0 Lowest 0 1 1 0 1 1 Highest					

Reset Value = X000 0000b
Not bit addressable



Flash Memory

As shown Figure 32, the Flash version of AT8xEB5114 implements 4 Kbytes of on-chip program/code memory.

The Flash memory increases EPROM and ROM functionality by in-circuit electrical erasure and programming. Thanks to the internal charge pump, the high voltage needed for programming or erasing Flash cells is generated on-chip using the standard VDD voltage.

Hardware programming mode is available using specific programming tool.

AT8xEB5114 features a Flash memory containing 4 Kbytes of program memory (user space) organized into 128 byte pages,

This Flash memory is programmable by parallel programming.

Figure 32. Flash Memory Architecture

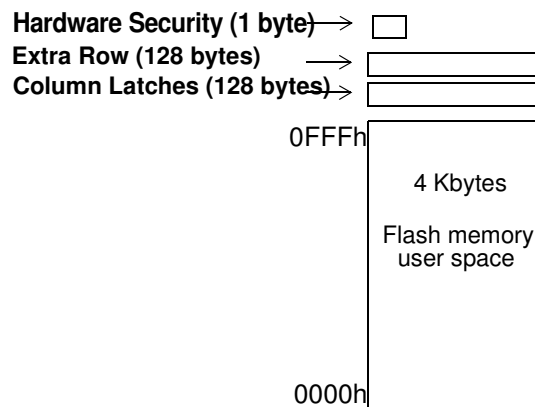

FM0 Memory Architecture

The Flash memory is made up of 4 blocks (see Figure 32):

- The memory array (user space) 4 Kbytes
- The Extra Row
- The Hardware security bits
- The column latch registers

User Space

This space is composed of a 4 Kbytes Flash memory organized in 32 pages of 128 bytes. It contains the user's application code.

Extra Row (XRow)

This row is a part of flash memory and has a size of 128 bytes. The extra row may contain information for boot loader usage.

Hardware security Byte

The Hardware Security Byte space is a part of flash memory and has a size of 1 byte. The 4 MSB can be read/written by software, the 4 LSB can only be read by software and written by hardware in parallel mode.

Column latches

The column latches, also part of flash memory, have a size of full page (128 bytes). The column latches are the entrance buffers of the three previous memory locations (user array, XROW and Hardware security byte).

Overview of Flash Memory Operations

The CPU interfaces to the Flash memory through the FCON register used to:

- Map the memory spaces in the addressable space

- Launch the programming of the memory spaces
- Get the status of the flash memory (busy/not busy)

Mapping of the Memory Space

By default, the user space is accessed by MOVC instruction for read only. The column latches space is made accessible by setting the FPS bit in FCON register. Writing is possible from 0000h to 0FFFh, address bits 6 to 0 are used to select an address within a page while bits 14 to 7 are used to select the programming address of the page.

The other memory spaces (user, extra row, hardware security) are made accessible in the code segment by programming bits FMOD0 and FMOD1 in FCON register in accordance with Table 57. A MOVC instruction is then used for reading these spaces.

Table 57. .FM0 Blocks Select Bits

FMOD1	FMOD0	FM0 Adressable space
0	0	User (0000h-FFFFh)
0	1	Extra Row(FF80h-FFFFh)
1	0	Hardware Security Byte (0000h)
1	1	reserved

Launching programming

FPL3:0 bits in FCON register are used to secure the launch of programming. A specific sequence must be written in these bits to unlock the write protection and to launch the programming. This sequence is 5xh followed by Axh. Table 33 summarizes the memory spaces to program according to FMOD1:0 bits.

Figure 33. Programming spaces

	Write to FCON				Operation
	FPL3:0	FPS	FMOD1	FMOD0	
User	5	X	0	0	No action
	A	X	0	0	Write the column latches in user space
Extra Row	5	X	0	1	No action
	A	X	0	1	Write the column latches in extra row space
Hardware Security Byte	5	X	1	0	No action
	A	X	1	0	Write the fuse bits space
Reserved	5	X	1	1	No action
	A	X	1	1	No action

- Notes:
1. The sequence 5xh and Axh must be executing without instructions between then otherwise the programming is aborted.
 2. Interrupts that may occur during programming time must be disable to avoid any spurious exit of the idle mode.

Status of the Flash Memory

The bit FBUSY in FCON register is used to indicate the status of programming. FBUSY is set when programming is in progress.

Loading the Column Latches

Any number of data from 1 byte to 128 bytes can be loaded in the column latches. This provides the capability to program the whole memory by byte, by page or by any number of bytes in a page.

When programming is launched, an automatic erase of the locations loaded in the column latches is first performed, then programming is effectively done. Thus no page or block erase is needed and only the loaded data are programmed in the corresponding page.

The following procedure is used to load the column latches and is summarized in Figure 34:

- Disable interrupt and map the column latch space by setting FPS bit.
- Load the DPTR with the address to load.
- Load Accumulator register with the data to load.
- Execute the MOVX @DPTR, A instruction.
- If needed loop the three last instructions until the page is completely loaded.
- unmap the column latch and Enable Interrupt

Figure 34. Column Latches Loading Procedure

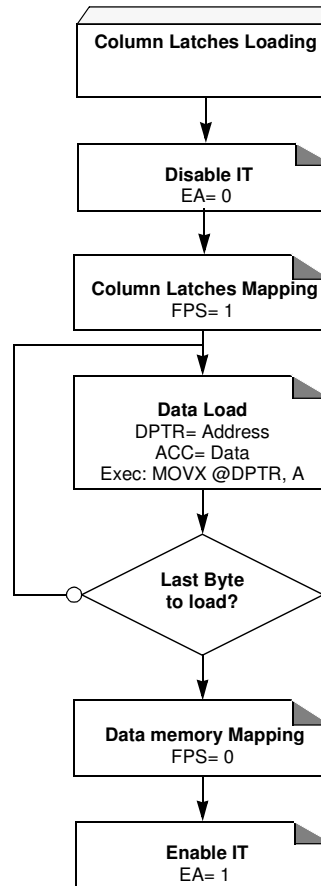

Note: The last page address used when loading the column latch is the one used to select the page programming address.

Programming the Flash Spaces User

The following procedure is used to program the User space and is summarized in Figure 35:

- Load data in the column latches from address 0000h to 0FFFh¹.
- Disable the interrupts.
- Launch the programming by writing the data sequence 50h followed by A0h in FCON register (only from FM1).
The end of the programming indicated by the FBUSY flag cleared.
- Enable the interrupts.

Note: 1. The last page address used when loading the column latch is the one used to select the page programming address.

Extra Row

The following procedure is used to program the Extra Row space and is summarized in Figure 35:

- Load data in the column latches from address FF80h to FFFFh.
- Disable the interrupts.
- Launch the programming by writing the data sequence 52h followed by A2h in FCON register (only from FM1).
The end of the programming indicated by the FBUSY flag cleared.
- Enable the interrupts.

Figure 35. Flash and Extra row Programming Procedure

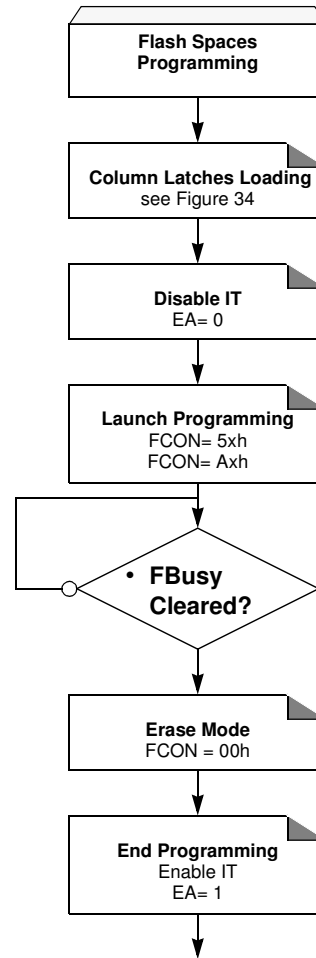

Hardware Security Byte

The following procedure is used to program the Hardware Security Byte space and is summarized in Figure 36:

- Set FPS and map Hardware byte (FCON = 0x0C)
- Disable the interrupts.
- Load DPTR at address 0000h.
- Load Accumulator register with the data to load.
- Execute the MOVX @DPTR, A instruction.
- Launch the programming by writing the data sequence 54h followed by A4h in FCON register (only from FM1).
The end of the programming indicated by the FBusy flag cleared.
- Enable the interrupts.

Figure 36. Hardware Programming Procedure

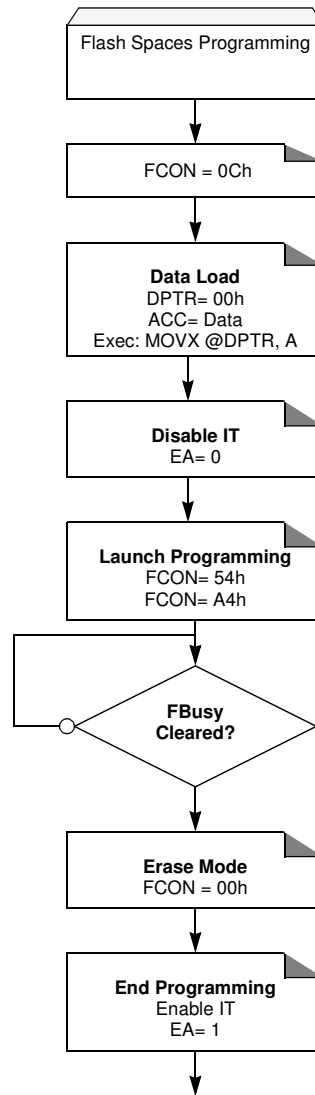
*Reading the Flash Spaces*

User

The following procedure is used to read the User space and is summarized in Figure 37:

- Map the User space by writing 00h in FCON register.
- Read one byte in Accumulator by executing `MOVC A,@A+DPTR` with `A= 0` & `DPTR= 0000h to FFFFh`.

Extra Row

The following procedure is used to read the Extra Row space and is summarized in Figure 37:

- Map the Extra Row space by writing 02h in FCON register.
- Read one byte in Accumulator by executing `MOVC A,@A+DPTR` with `A= 0` & `DPTR= FF80h to FFFFh`.
- Clear FCON to unmap the Extra Row.

Hardware Security Byte

The following procedure is used to read the Hardware Security space and is summarized in Figure 37:

- Map the Hardware Security space by writing 04h in FCON register.
- Read the byte in Accumulator by executing MOVC A,@A+DPTR with A= 0 & DPTR= 0000h.
- Clear FCON to unmap the Hardware Security Byte.

Figure 37. Reading Procedure

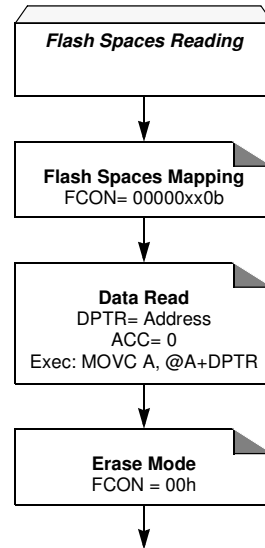

Flash Protection from Parallel Programming

The three lock bits in Hardware Security Byte are programmed according to Table 58, will provide different level of protection for the on-chip code and data located in flash memory.

The only way for write this bits are the parallel mode.

Table 58. Program Lock Bit

Program Lock Bits			Protection Description
Security level	LB1	LB0	
1	U	U	No program lock feature enabled.
2	U	P	Writing Flash data from programmer is disabled but still allowed from internal code execution.
3	P	U	Writing and reading Flash data from programmer is disabled but still allowed from internal code execution.

WARNING: Security level 2 and 3 should only be programmed after Flash and Core verification.

Registers

Table 59. FCON: Flash Control Register
FCON - Flash Control Register (D1h)

7	6	5	4	3	2	1	0
FPL3	FPL2	FPL1	FPL0	FPS	FMOD1	FMOD0	FBUSY
Bit Number	Bit Mnemonic	Description					
7-4	FPL3:0	Programming Launch Command Bits Write 5Xh followed by AXh to launch the programming according to FMOD1:0. (see Figure 33.)					
3	FPS	Flash Map Program Space Set to map the column latch space in the data memory space. Clear to re-map the data memory space.					
2-1	FMOD1:0	Flash Mode See Table 57 or Table 33.					
0	FBUSY	Flash Busy Set by hardware when programming is in progress. Clear by hardware when programming is done. Can not be cleared by software.					

Reset Value= 0000 0000b

AT8xEB5114 ROM

ROM Structure

The AT8xEB5114 ROM memory is divided in two different arrays:

- the code array: 4 Kbytes.
- the configuration byte: 1 byte.

Hardware Configuration Byte

The configuration byte sets the starting microcontroller options and the security levels.

The starting default options are X1 mode, Oscillator A.

Table 60. Hardware Security Byte (HSB)

HSB (S:EFh)

Power configuration Register

7	6	5	4	3	2	1	0
X2	RST_OSC1	RST_OSC0	RST_OCLK	-	-	LB1	LB0

Bit Number	Bit Mnemonic	Description
7	X2	X2 Mode Clear to force X2 mode (CkOut = OscOut) Set to use the prescaler mode (CkOut = OscOut / (2*(16-M)))
6	RST_OSC1	Oscillator bit 1 on reset
5	RST_OSC0	Oscillator bit 0 on reset Oscillator bit on reset 11: allow OSCA 10: allow OSCB 01: allow OSCC 00: reserved
4	RST_OCLK	Output clocking signal after RESET Clear to start the microcontroller with a low level on P3.5 followed by an output clocking signal on P3.5 as soon as the microcontroller is started. This signal has a 1/3 high 2/3 low signal. Its frequency is equal to (CKout / 3). Set to start on normal conditions: No signal on P3.5 which is pulled up.
3	CKRLRV	CKRL Reset Value If set, the microcontroller starts with the prescaler reset value = XXXX 1000 (OscOut = CkOut/16). If clear, the microcontroller starts with a prescaler reset value = XXXX 1111 (OscOut = CkOut/2).
2	-	Reserved
1-0	LB1-0	User Program Lock Bits See Table 61 on page 81

HSB = 1111 XX11b

Note: Whatever the value of RST_OSC, the XTAL1 input is always validated in order to enter in test modes.

ROM Lock System

The program Lock system, when programmed, protects the on-chip program against software piracy.

Program ROM lock Bits

The lock bits when programmed according to Table 61 will provide different level of protection for the on-chip code and data.

Table 61. Program Lock bits

Program Lock Bits			Protection Description
Security level	LB1	LB0	
1	U	U	No program lock feature enabled.
3	P	U	Reading ROM data from programmer is disabled.

U: unprogrammed

P: programmed



Stacked EEPROM

Overview

The AT8xEB5114 features a stacked 2-wire serial data EEPROM. The data EEPROM allows to save up to 256 bytes. The EEPROM is internally connected to P3.6 and P3.7 which are respectively connected to the SDA and the SCL pins.

Protocol

In order to access this memory, it is necessary to use software subroutines according to the AT24C02 datasheet. Nevertheless, because the internal pull-up resistors of the AT8xEB5114 is quite high (around $100\text{K}\Omega$), the protocol should be slowed in order to be sure that the SDA pin can rise to the high level before reading it.

Another solution to keep the access to the EEPROM in specification is to work with a software pull-up.

Using a software pull-up, consists of forcing a low level at the output pin of the microcontroller before configuring it as an input (high level).

The C51 the ports are “quasi-bidirectional” ports. It means that the ports can be configured as output low or as input high. In case a port is configured as an output low, it can sink a current and all internal pull-ups are disconnected. In case a port is configured as an input high, it is pulled up with a strong pull-up (a few hundreds Ohms resistor) for 2 clock periods. Then, if the port is externally connected to a low level, it is only kept high with a weak pull up (around $100\text{K}\Omega$), and if not, the high level is latched high thanks to a medium pull (around $10\text{k}\Omega$).

Thus, when the port is configured as an input, and when this input has been read at a low level, there is a pull-up of around $100\text{K}\Omega$, which is quite high, to quickly load the SDA capacitance. So in order to help the reading of a high level just after the reading of a low level, it is possible to force a transition of the SDA port from an input state (1), to an output low state (0), followed by a new transition from this output low state to input state; In this case, the high pull-up has been replaced with a low pull-up which warrants a good reading of the data.

Electrical Characteristics

Absolute Maximum Ratings^(*)

Ambient Temperature Under Bias:
 C = commercial..... 0°C to 70°C
 I = industrial -40°C to 85°C
 Storage Temperature -65°C to + 150°C
 Voltage on V_{CC} to V_{SS}.....-0.5 V to + 4.6 V
 Voltage on Any Pin to V_{SS}-0.5 V to V_{CC} + 0.5 V
 Power Dissipation..... 1 W
 Electro-static discharge voltage 1500 V

*NOTICE: Stresses at or above those listed under “Absolute Maximum Ratings” may cause permanent damage to the device. This is a stress rating only and functional operation of the device at these or any other conditions above those indicated in the operational sections of this specification is not implied. Exposure to absolute maximum rating conditions may affect device reliability. Power Dissipation value is based on the maximum allowable die temperature and the thermal resistance of the package.

Power Consumption Measurement

Since the introduction of the first C51 devices, every manufacturer made operating I_{cc} measurements under reset, which made sense for the designs where the CPU was running under reset. In our new devices, the CPU is no longer active during reset, so the power consumption is very low and this is not really representative of what will happen in the customer’s system. Thus, while keeping measurements under Reset, we present a new way to measure the operating I_{cc}:

Using an internal test ROM, the following code is executed:

Label: SJMP Label (80 FE)

Ports 3, 4 are disconnected, RST = V_{CC}, XTAL2 is not connected and XTAL1 is driven by the clock.

This is much more representative of the real operating I_{cc}.

DC Parameters for Low Voltage

T_A = 0°C to +70°C; V_{SS} = 0 V; V_{CC} = 3 V to 3.6 V; F = 0 to 24 MHz.
 T_A = -40°C to +85°C; V_{SS} = 0 V; V_{CC} = 3 V to 3.6 V; F = 0 to 24 MHz.

Table 1. DC Parameters for Low Voltage

Symbol	Parameter	Min	Typ	Max	Unit	Test Conditions
V _{IL}	Input Low Voltage	-0.5		0.8	V	
V _{IH}	Input High Voltage except XTAL1, RST	2		V _{CC} + 0.5	V	
V _{IH1}	Input High Voltage, XTAL1, RST	0.7 V _{CC}		V _{CC} + 0.5	V	
V _{OL}	Output Low Voltage, ports 3, 4 ⁽⁶⁾			0.3	V	I _{OL} = 100 μA
				0.45	V	I _{OL} = 1.6 mA
				1.0	V	I _{OL} = 3.2 mA
V _{OH}	Output High Voltage, ports 3, 4 ⁽⁶⁾	0.9 V _{CC}			V	I _{OH} = -10 μA
		V _{CC} - 0.7			V	I _{OH} = -30 μA
		V _{CC} - 1.4			V	I _{OH} = -50 μA

Table 1. DC Parameters for Low Voltage (Continued)

Symbol	Parameter	Min	Typ	Max	Unit	Test Conditions
V _{OH2}	Output High Voltage, ports 3, 4. ⁽⁶⁾ mode Push pull	0.9V _{CC} V _{CC} - 0.7 V _{CC} - 1.5			V V V	I _{OH} = -100 μA I _{OH} = - 1 mA I _{OH} = - 2 mA
I _{IL}	Logical 0 Input Current ports 3 and 4 ⁽⁷⁾			-50	μA	V _{in} = 0.45 V
I _{IL}	Input Leakage Current			±10	μA	0.45 V < V _{in} < V _{CC}
I _{TL}	Logical 1 to 0 Transition Current, ports 3, 4 ⁽⁸⁾			-650	μA	V _{in} = 2.0 V
R _{RST}	RST Pull up Resistor	50	90 ⁽⁵⁾	200	kΩ	
C _{IO}	Capacitance of I/O Buffer			10	pF	F _c = 1 MHz T _A = 25°C
I _{PD}	Power Down Current		50	200	μA	V _{CC} = 3.0 V to 3.6 V ⁽³⁾
F _{OSCB}	OSCB unlocked frequency	10.8	12	13.2	MHz	With ideal R and C
F _{OSCB}	OSCB locked frequency	11.5	12	12.5	MHz	With ideal R and C
F _{OSCC}	OSCC frequency	8.4	14	19.6	MHz	
I _{CC} under RESET	Power Supply Current Maximum values, X1 mode, OSCA oscillator ⁽⁹⁾			4	mA	V _{CC} = 3.3 V ⁽¹⁾ OSCA + Prescaler
I _{CC} operating	Power Supply Current Maximum values, X1 mode, OSCA oscillator ⁽⁹⁾			0.4*F+3	mA	V _{CC} = 3.3 V ⁽¹⁰⁾ F in MHz
I _{CC} idle	Power Supply Current Maximum values, X1 mode, OSCA oscillator ⁽⁹⁾			6	mA	V _{CC} = 3.3 V ⁽²⁾
I _{CC} under RESET	Power Supply Current Maximum values, X1 mode, OSCB oscillator ⁽⁹⁾			900	μA	V _{CC} = 3.3 V ⁽¹⁾ OSCB + Prescaler
I _{CC} operating	Power Supply Current Maximum values, X1 mode, OSCB oscillator ⁽⁹⁾			5	mA	V _{CC} = 3.3 V ⁽¹⁰⁾
I _{CC} idle	Power Supply Current Maximum values, X1 mode, OSCB oscillator ⁽⁹⁾			4.8	mA	V _{CC} = 3.3 V ⁽²⁾
I _{CC} under RESET	Power Supply Current Maximum values, X1 mode, OSCC oscillator ⁽⁹⁾			650	μA	V _{CC} = 3.3 V ⁽¹⁾ OSCC + Prescaler
I _{CC} operating	Power Supply Current Maximum values, X1 mode, OSCC oscillator ⁽⁹⁾			5	mA	V _{CC} = 3.3 V ⁽¹⁰⁾
I _{CC} idle	Power Supply Current Maximum values, X1 mode, OSCC oscillator ⁽⁹⁾			4.8	mA	V _{CC} = 3.3 V ⁽²⁾
V _{RET}	Supply voltage during power down mode	2.7			V	
V _{PFDP}	Power fail high level threshold	2.6	2.8	2.95	V	
V _{PFDM}	Power fail low level threshold (default)	2.45	2.55	2.7	V	
	Power fail hysteresis V _{PFDP} - V _{PFDM}	150	250	350	mV	
t _G	Glitch maximum time		100		ns	V _{CC} down to 2.5 V

Table 1. DC Parameters for Low Voltage (Continued)

Symbol	Parameter	Min	Typ	Max	Unit	Test Conditions
t_R	Supply rise time	1us		1s		

- Notes:
- I_{CC} under reset is measured with all output pins disconnected; XTAL1 driven with T_{CLCH} , $T_{CHCL} = 5$ ns (see Figure 42.), $V_{IL} = V_{SS} + 0.5$ V, $V_{IH} = V_{CC} - 0.5$ V; XTAL2 N.C.; $V_{pp} = RST = V_{CC}$. I_{CC} would be slightly higher if a crystal oscillator used
 - Idle I_{CC} is measured with all output pins disconnected; XTAL1 driven with T_{CLCH} , $T_{CHCL} = 5$ ns, $V_{IL} = V_{SS} + 0.5$ V, $V_{IH} = V_{CC} - 0.5$ V; XTAL2 N.C.; $V_{pp} = RST = V_{SS}$ (see Figure 40.).
 - Power Down I_{CC} is measured with all output pins disconnected; $V_{pp} = V_{SS}$; XTAL2 NC.; $RST = V_{CC}$ (see Figure 41.).
 - Not Applicable
 - Typical are based on a limited number of samples and are not guaranteed. The values listed are at room temperature and 3.3V.
 - If I_{OL} exceeds the test condition, V_{OL} may exceed the related specification. Pins are not guaranteed to sink current greater than the listed test conditions.
 - For other values, please contact your sales office.
 - When port configuration have weak pull-up activated.
 - When port configuration is quasi-bidirectional.
 - Operating I_{CC} is measured with all output pins disconnected; XTAL1 driven with T_{CLCH} , $T_{CHCL} = 5$ ns (see Figure 42.), $V_{IL} = V_{SS} + 0.5$ V, $V_{IH} = V_{CC} - 0.5$ V; XTAL2 N.C.; $\overline{RST} = V_{CC}$:. The internal ROM runs the code 80 FE (label: SJMP label). I_{CC} would be slightly higher if a crystal oscillator is used. Measurements are made with OTP products when possible, which is the worst case.

Figure 38. I_{CC} Test Condition, under reset

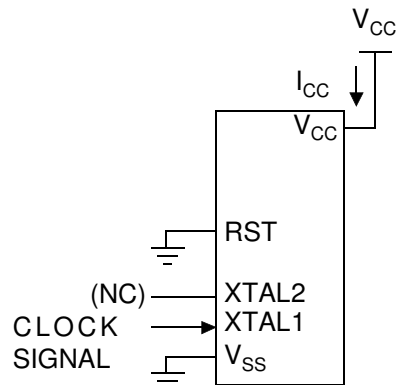

All other pins are disconnected.

Figure 39. Operating I_{CC} Test Condition

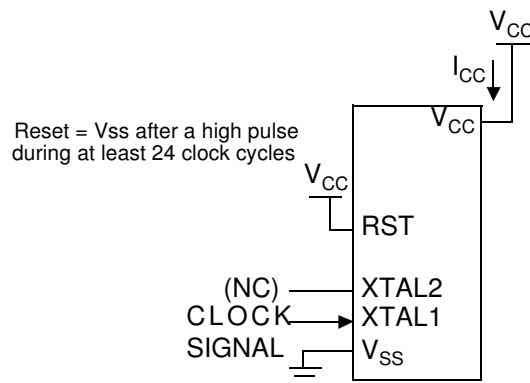

All other pins are disconnected.

Figure 40. I_{CC} Test Condition, Idle Mode

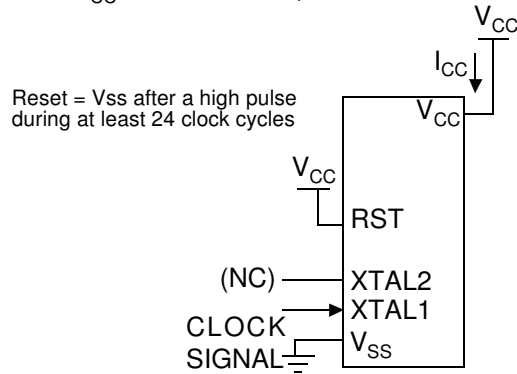

All other pins are disconnected.

Figure 41. I_{CC} Test Condition, Power-Down Mode

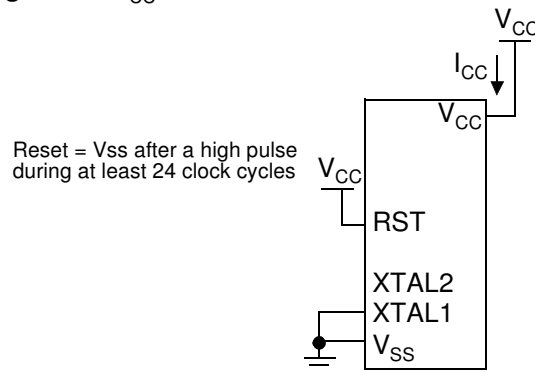

All other pins are disconnected.

Figure 42. Clock Signal Waveform for I_{CC} Tests in Active and Idle Modes

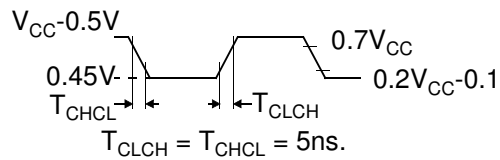

DC Parameters for A/D Converter

$T_A = 0^\circ\text{C}$ to $+70^\circ\text{C}$; $V_{SS} = 0\text{ V}$; $V_{CC} = 3\text{ V}$ to $3,6\text{ V}$; $F = 0$ to 24 MHz .
 $T_A = -40^\circ\text{C}$ to $+85^\circ\text{C}$; $V_{SS} = 0\text{ V}$; $V_{CC} = 3\text{ V}$ to $3,6\text{ V}$; $F = 0$ to 24 MHz .

Table 2. DC Parameters for Low Voltage

Symbol	Parameter	Min	Typ	Max	Unit	Test Conditions
	Resolution		10		bit	
AVin	Analog input voltage	Vss - 0.2		Vcc + 0.2	V	
Rref	Resistance between Vref and Vss	13	18	24	KO hm	
Vref	Value of integrated voltage source	2.30	2.40	2.50	V	
Vref drift	Vref Voltage drift over temperature			150	$\mu\text{V}/^\circ\text{C}$	
Lref	Load on integrated voltage source	10			KO hm	
Cai	Analog input Capacitance		60		pF	During sampling
	Integral non linearity		1	2	lsb	With ideal external Ref (1)
	Differential non linearity		0.5	1	lsb	
	Offset error	-2		2	lsb	
	Input source impedance			1	KO hm	For 10 bit resolution at maximum speed

Note: (1) With $\text{lsb} = 2.4/1024 = 2.4\text{ mV}$, typical integral linearity is:

$$\frac{(2, 4 - V_{ref})}{2, 4 \times 10^{-3}}$$

AC Parameters

Explanation of the AC Symbols

Each timing symbol has 5 characters. The first character is always a "T" (stands for Time). The other characters, depending on their positions, stand for the name of a signal or the logical status of that signal. The following is a list of all the characters and what they stand for.

Example: T_{XHDV} = Time from clock rising edge to input data valid.

$T_A = 0$ to $+70^\circ\text{C}$ (commercial temperature range); $V_{SS} = 0\text{ V}$; $3\text{ V} < V_{CC} < 3.6\text{ V}$; -L range.
 $T_A = -40^\circ\text{C}$ to $+85^\circ\text{C}$ (industrial temperature range); $V_{SS} = 0\text{ V}$; $3\text{ V} < V_{CC} < 3.6\text{ V}$; -L range.

Table 3. gives the maximum applicable load capacitance for Port 1, 3 and 4. Timings will be guaranteed if these capacitances are respected. Higher capacitance values can be used, but timings will then be degraded.

Table 3. Load Capacitance versus speed range, in pF

	-L
Port 3 & 4	60

Table 4. Max frequency for Derating Formula Regarding the Speed Grade

	-L X1 mode	-L X2 mode
Freq (MHz)	40 ⁽¹⁾	20
T (ns)	25	50

- Oscillator speed is limited to 24 Mhz

External Clock Drive Characteristics (XTAL1)

Symbol	Parameter	Min	Max	Units
T _{CLCL}	Oscillator Period	25		ns
T _{CHCX}	High Time	5		ns
T _{CLCX}	Low Time	5		ns
T _{CLCH}	Rise Time		5	ns
T _{CHCL}	Fall Time		5	ns
T _{CHCX} /T _{CLCX}	Cyclic ratio in X2 mode	40	60	%

External Clock Drive Waveforms

Figure 43. External Clock Drive Waveforms

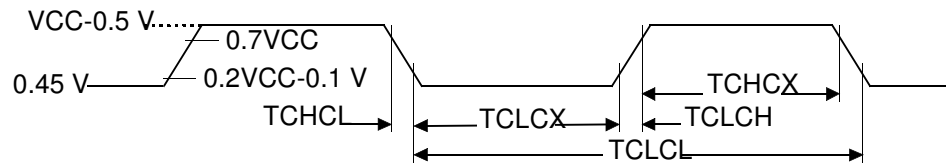

A/D Converter

Symbol	Parameter	Min	Typ	Max	Units
	Conversion time		11		Clock periods (1 for sampling, 10 for conversion)
FConv_Ck	Clock Conversion frequency			550 (1)	kHz
	Sampling frequency	10		50	kilo samples per second

Notes: 1. For 10 bits resolution

PWM Outputs

Symbol	Parameter	Min	Typ	Max	Units
Tr	Rise time of PWM outputs		60		ns (load 300 pF) Can be slower
Tf	Fall time of PWM outputs		30		ns (300 pF) Can be slower

AC Testing Input/Output Waveforms

Figure 44. AC Testing Input/Output Waveforms

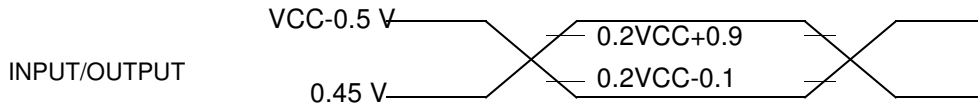

AC inputs during testing are driven at $V_{CC} - 0.5$ for a logic “1” and 0.45V for a logic “0”. Timing measurement are made at V_{IH} min for a logic “1” and V_{IL} max for a logic “0”.

Float Waveforms

Figure 45. Float Waveforms

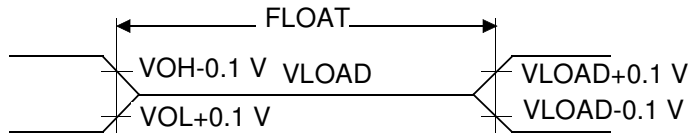

For timing purposes as port pin is no longer floating when a 100 mV change from load voltage occurs and begins to float when a 100 mV change from the loaded V_{OH}/V_{OL} level occurs. $I_{OL}/I_{OH} \geq \pm 20\text{mA}$.

Clock Waveforms

Valid in normal clock mode. In X2 mode XTAL2 signal must be changed to XTAL2 divided by two.

Figure 46. Clock Waveforms

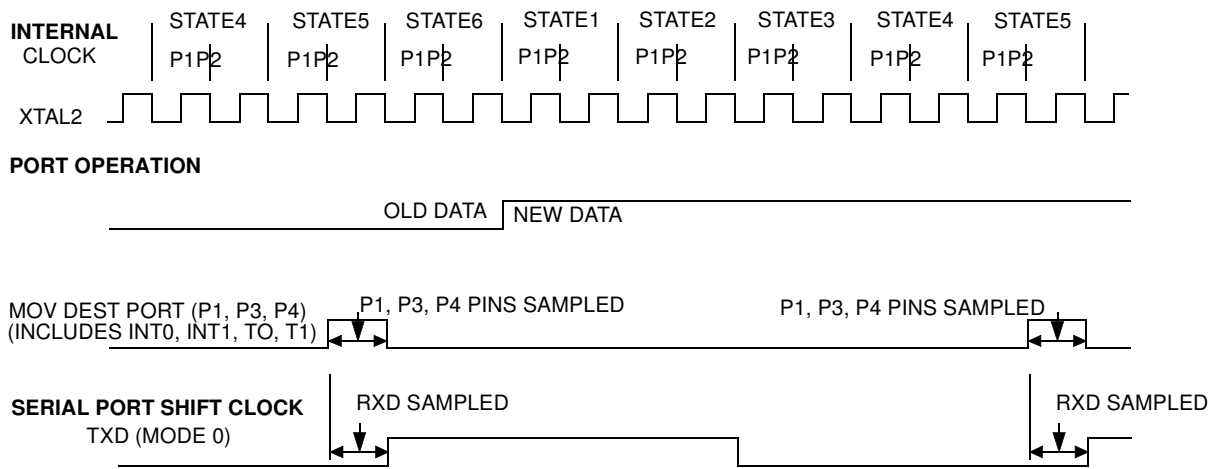

This diagram indicates when signals are clocked internally. The time it takes the signals to propagate to the pins, however, ranges from 25 to 125 ns. This propagation delay is dependent on variables such as temperature and pin loading. Propagation also varies from output to output and component. Typically though ($T_A=25^\circ\text{C}$ fully loaded) $\overline{\text{RD}}$ and $\overline{\text{WR}}$ propagation delays are approximately 50 ns. The other signals are typically 85 ns. Propagation delays are incorporated in the AC specifications.

Typical Application

Figure 47. Typical Application Diagram

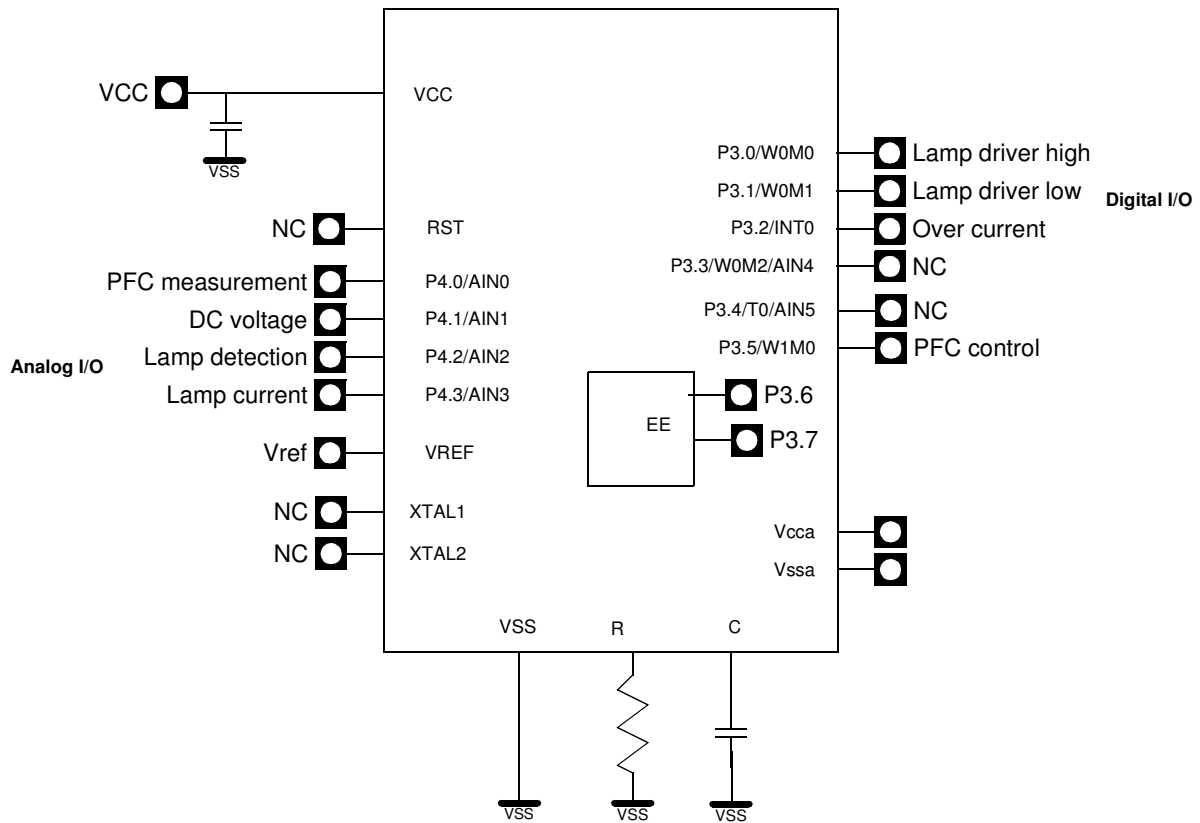

Ordering Information

Table 5. Possible Order Entries

Part Number	Memory Size	Supply Voltage	Temperature Range	Max Frequency	Package	Packing
AT83EB5114xxxTGRIL	OBSOLETE					
AT89EB5114-TGSIL						
AT83EB5114xxxTGRUL	4Kb ROM	3 to 3.6V	Industrial & Green	40 MHz	S020	Reel
AT89EB5114-TGSUL	4Kb Flash	3 to 3.6V	Industrial & Green	40 MHz	SO20	Stick

Package Drawings

SO20

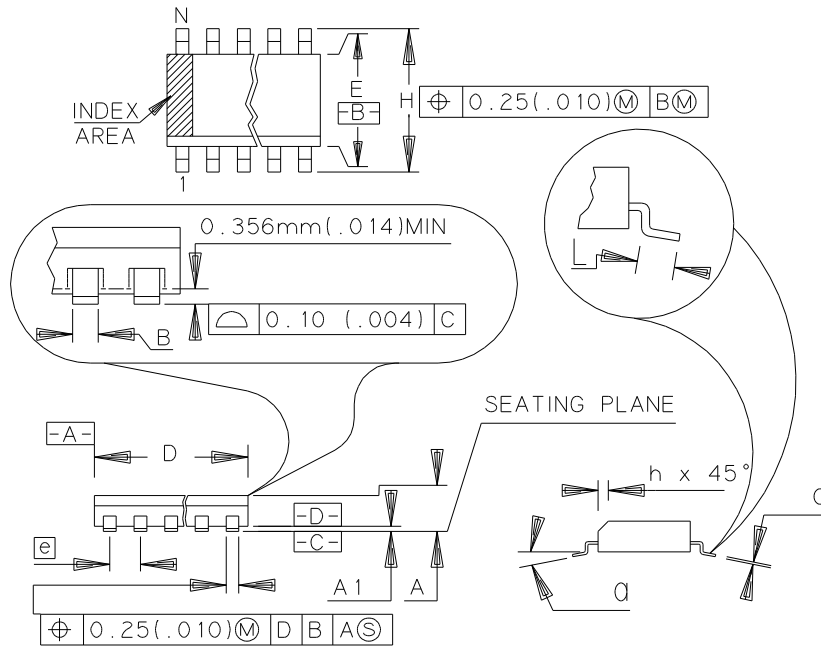

	MM		INCH	
	A	2.35	2.65	.093
A1	0.10	0.30	.004	.012
B	0.35	0.49	.014	.019
C	0.23	0.32	.009	.013
D	12.60	13.00	.496	.512
E	7.40	7.60	.291	.299
e	1.27	BSC	.050	BSC
H	10.00	10.65	.394	.419
h	0.25	0.75	.010	.029
L	0.40	1.27	.016	.050
N	20		20	
α	0°		8°	

Document Revision History

Changes from 4311B to 4311C

1. Removed non-green part numbers from Ordering Information.



Atmel Corporation

2325 Orchard Parkway
San Jose, CA 95131, USA
Tel: 1(408) 441-0311
Fax: 1(408) 487-2600

Regional Headquarters

Europe

Atmel Sarl
Route des Arsenaux 41
Case Postale 80
CH-1705 Fribourg
Switzerland
Tel: (41) 26-426-5555
Fax: (41) 26-426-5500

Asia

Room 1219
Chinachem Golden Plaza
77 Mody Road Tsimshatsui
East Kowloon
Hong Kong
Tel: (852) 2721-9778
Fax: (852) 2722-1369

Japan

9F, Tonetsu Shinkawa Bldg.
1-24-8 Shinkawa
Chuo-ku, Tokyo 104-0033
Japan
Tel: (81) 3-3523-3551
Fax: (81) 3-3523-7581

Atmel Operations

Memory

2325 Orchard Parkway
San Jose, CA 95131, USA
Tel: 1(408) 441-0311
Fax: 1(408) 436-4314

Microcontrollers

2325 Orchard Parkway
San Jose, CA 95131, USA
Tel: 1(408) 441-0311
Fax: 1(408) 436-4314

La Chantrerie
BP 70602
44306 Nantes Cedex 3, France
Tel: (33) 2-40-18-18-18
Fax: (33) 2-40-18-19-60

ASIC/ASSP/Smart Cards

Zone Industrielle
13106 Rousset Cedex, France
Tel: (33) 4-42-53-60-00
Fax: (33) 4-42-53-60-01

1150 East Cheyenne Mtn. Blvd.
Colorado Springs, CO 80906, USA
Tel: 1(719) 576-3300
Fax: 1(719) 540-1759

Scottish Enterprise Technology Park
Maxwell Building
East Kilbride G75 0QR, Scotland
Tel: (44) 1355-803-000
Fax: (44) 1355-242-743

RF/Automotive

Theresienstrasse 2
Postfach 3535
74025 Heilbronn, Germany
Tel: (49) 71-31-67-0
Fax: (49) 71-31-67-2340

1150 East Cheyenne Mtn. Blvd.
Colorado Springs, CO 80906, USA
Tel: 1(719) 576-3300
Fax: 1(719) 540-1759

Biometrics/Imaging/Hi-Rel MPU/ High Speed Converters/RF Datacom

Avenue de Rochepleine
BP 123
38521 Saint-Egreve Cedex, France
Tel: (33) 4-76-58-30-00
Fax: (33) 4-76-58-34-80

Literature Requests

www.atmel.com/literature

Disclaimer: The information in this document is provided in connection with Atmel products. No license, express or implied, by estoppel or otherwise, to any intellectual property right is granted by this document or in connection with the sale of Atmel products. **EXCEPT AS SET FORTH IN ATMEL'S TERMS AND CONDITIONS OF SALE LOCATED ON ATMEL'S WEB SITE, ATMEL ASSUMES NO LIABILITY WHATSOEVER AND DISCLAIMS ANY EXPRESS, IMPLIED OR STATUTORY WARRANTY RELATING TO ITS PRODUCTS INCLUDING, BUT NOT LIMITED TO, THE IMPLIED WARRANTY OF MERCHANTABILITY, FITNESS FOR A PARTICULAR PURPOSE, OR NON-INFRINGEMENT. IN NO EVENT SHALL ATMEL BE LIABLE FOR ANY DIRECT, INDIRECT, CONSEQUENTIAL, PUNITIVE, SPECIAL OR INCIDENTAL DAMAGES (INCLUDING, WITHOUT LIMITATION, DAMAGES FOR LOSS OF PROFITS, BUSINESS INTERRUPTION, OR LOSS OF INFORMATION) ARISING OUT OF THE USE OR INABILITY TO USE THIS DOCUMENT, EVEN IF ATMEL HAS BEEN ADVISED OF THE POSSIBILITY OF SUCH DAMAGES.** Atmel makes no representations or warranties with respect to the accuracy or completeness of the contents of this document and reserves the right to make changes to specifications and product descriptions at any time without notice. Atmel does not make any commitment to update the information contained herein. Unless specifically provided otherwise, Atmel products are not suitable for, and shall not be used in, automotive applications. Atmel's products are not intended, authorized, or warranted for use as components in applications intended to support or sustain life.

© Atmel Corporation 2008. All rights reserved. Atmel®, logo and combinations thereof, are registered trademarks, and Everywhere You Are™ are the trademarks of Atmel Corporation or its subsidiaries. Other terms and product names may be trademarks of others.



Printed on recycled paper.

4311C-8051-02/08