

THIS DRAWING IS UNPUBLISHED. RELEASED FOR PUBLICATION
 © COPYRIGHT - By - ALL RIGHTS RESERVED.

REVISIONS					
P	LTR	DESCRIPTION	DATE	DWN	APVD
B1		REVISED PER ECO-16-004800	12SEP2016	NK	MZ
C		REVISED PER ECO-17-018437	21DEC2017	RS	MZ
D		REVISED PER ECO-19-001991	08FEB2019	RS	MZ

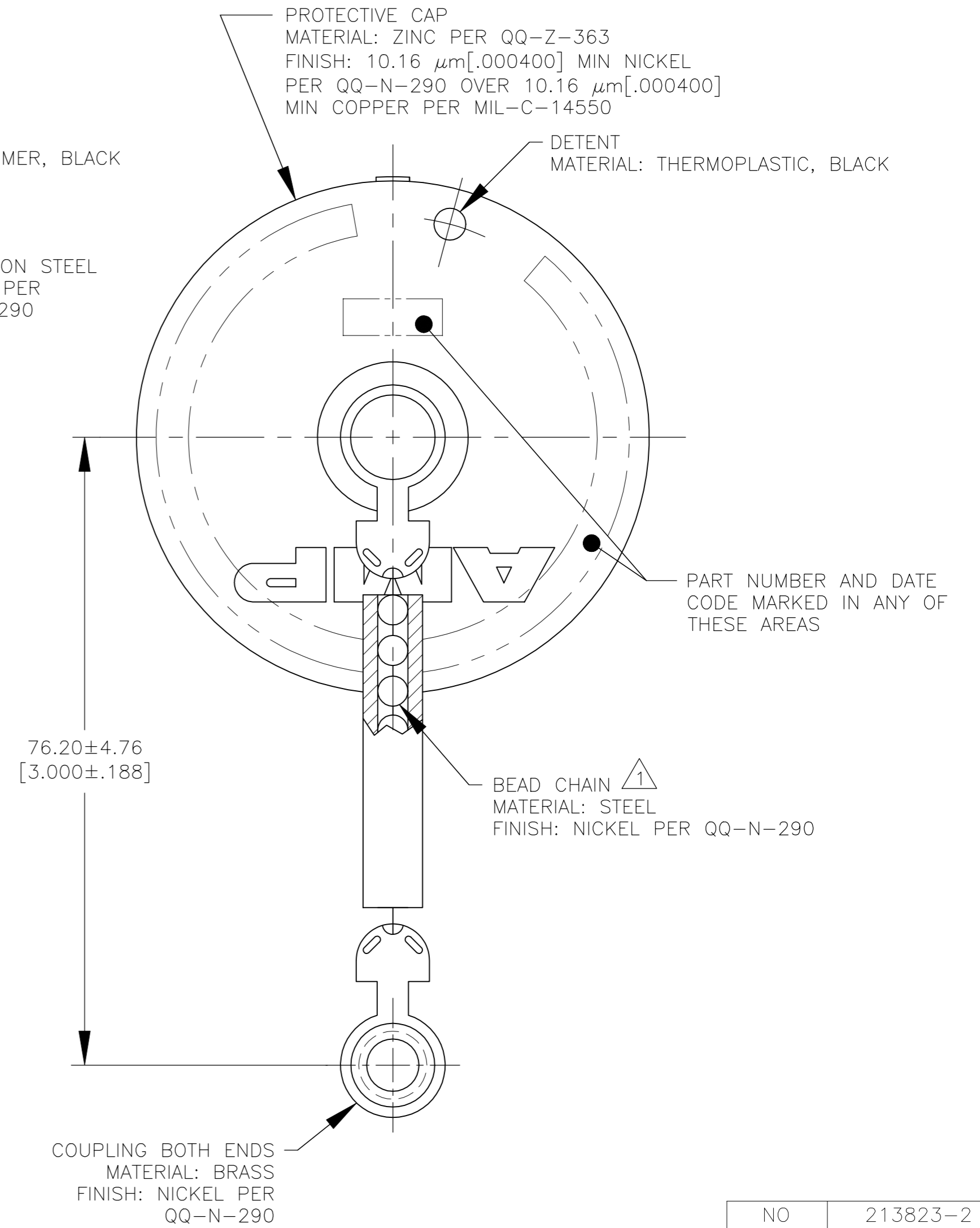
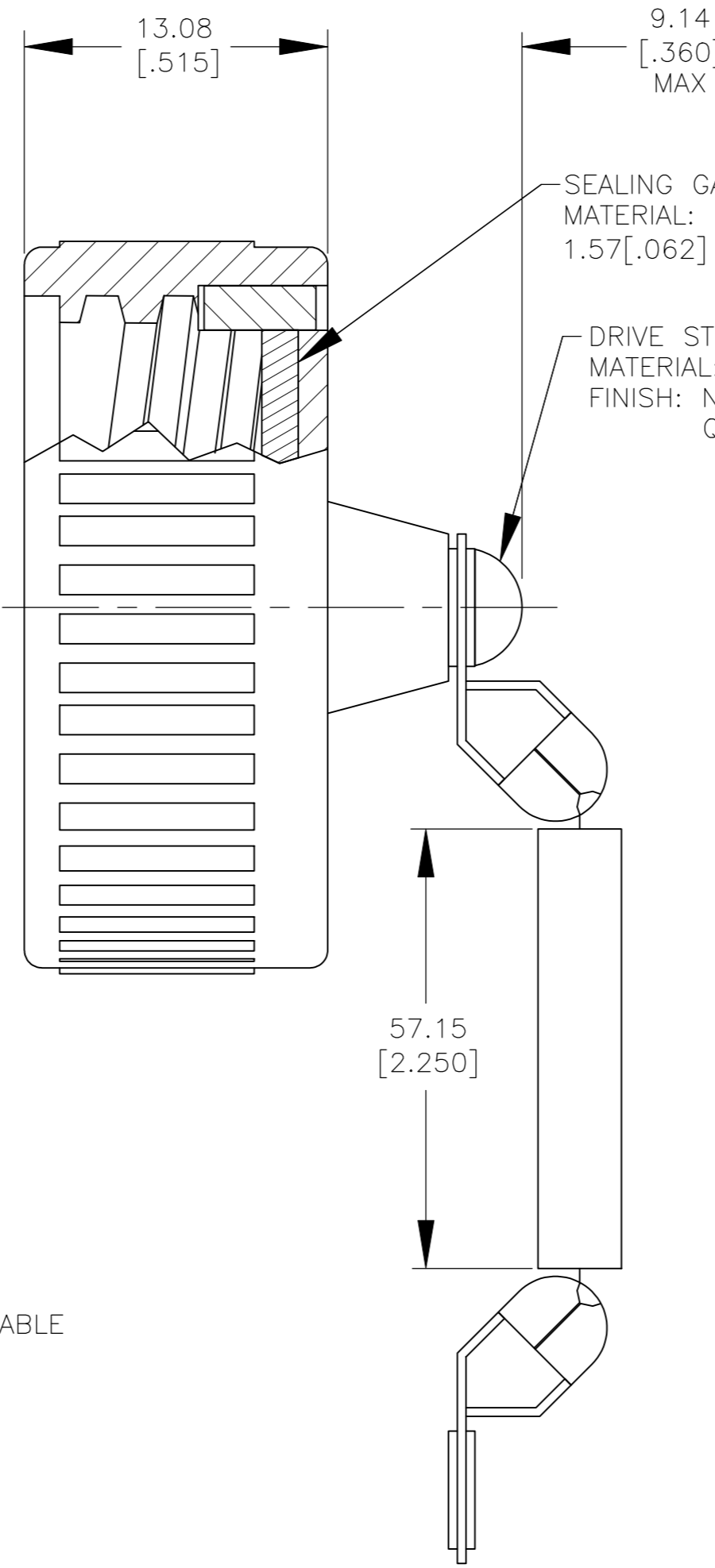
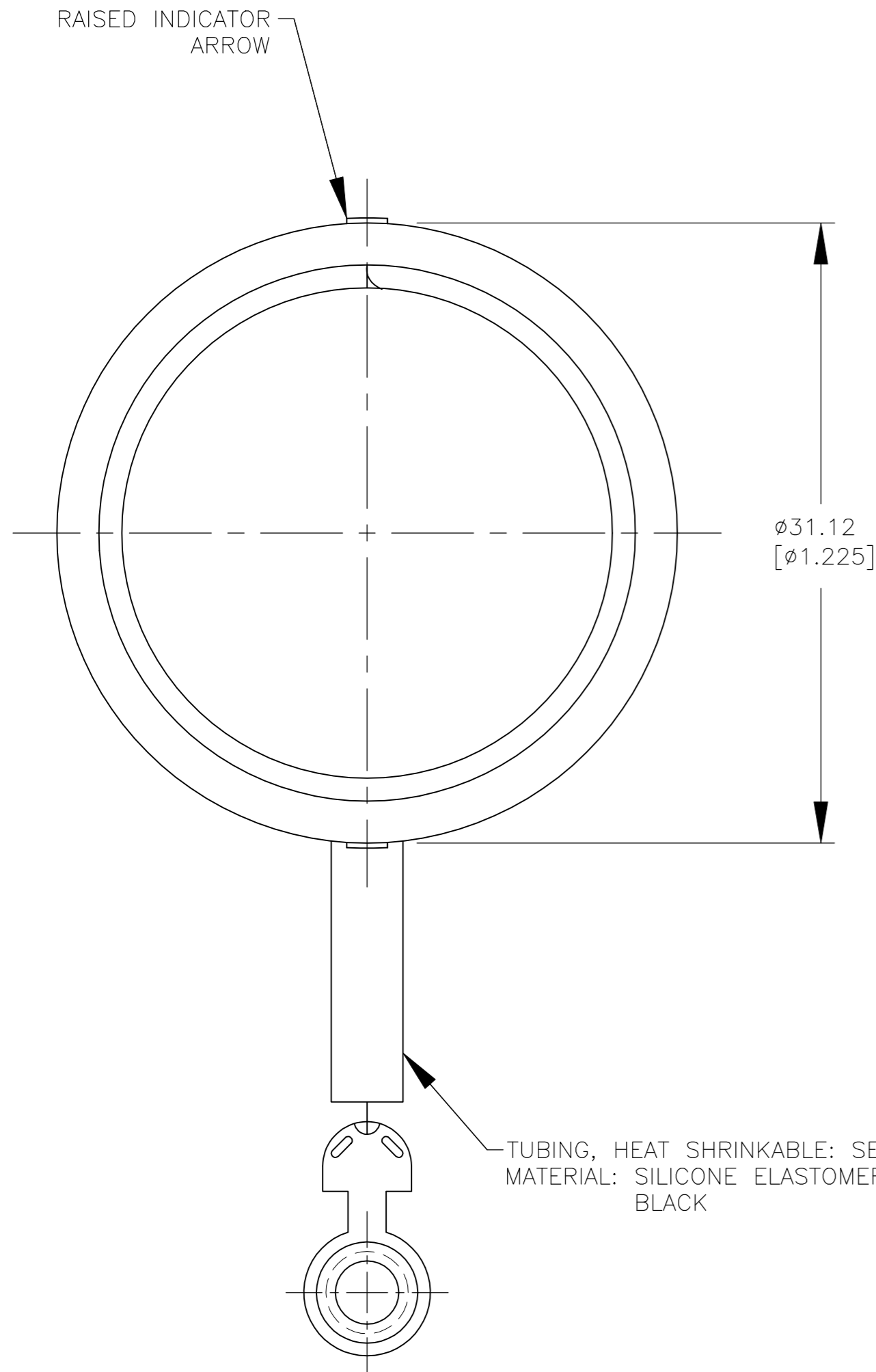

TUBING, HEAT SHRINKABLE: SEE TABLE
MATERIAL: SILICONE ELASTOMER, BLACK

¹ BEADED PORTION OF CHAIN MUST ROTATE FREELY. THE EYELET OF THE CHAIN IS NOT REQUIRED TO SPIN FREELY AROUND THE STUD.

	NO	213823-2
OBSOLETE	YES	-213823-1-
	TUBING	PART NUMBER

THIS DRAWING IS A CONTROLLED DOCUMENT.		DWN K.FOLTZ 01/20/95	STE TE Connectivity	
DIMENSIONS: mm [INCHES]		CHK R.STONE 01/20/95		
TOLERANCES UNLESS OTHERWISE SPECIFIED:		APVD A.FRANTUM 01/23/95	NAME PROTECTIVE CAP ASSEMBLY, SIZE 14, CMC	
0 PLC ± -		PRODUCT SPEC	SIZE	CAGE CODE
1 PLC ± -		APPLICATION SPEC	A2	00779
2 PLC ± 0.25 [.010]			DRAWING NO	RESTRICTED TO
3 PLC ± -			C=213823	-
4 PLC ± -			SCALE	SHEET
ANGLES ± -		WEIGHT	4:1	1 of 1
FINISH		CUSTOMER DRAWING	REV	D
SEE CALLOUTS				