

CODE	DIM "M" MATING LENGTH	CONTACT TYPE
PA	[N/A]	POWER

spec ref	See Notes		dr	GUANG SHI	2012-01-04	projection 	MM ←→	size	A4	scale	1:1	
tolerance std	TOLERANCES UNLESS OTHERWISE SPECIFIED		eng	XQ WANG	2012-01-04			ecn no	-			
See Notes			chr	PM ZHENG	2012-01-04							
surface	linear	0.X ±0.5 0.XX ±0.25 0.XXX ±0.1	appr	JOSEPH HSIA	2012-01-04	product family	PwrBlade		rel level	Released		
	angular	0° ±2°	www.fci.com		title	8ACP RIGHT ANGLE SOLDER HEADER		dwg no	51939-609		rev	A
			cat. no.	-				Product - Customer Drw		sheet 1 of 4		

PRODUCT NUMBER

51939-609--
NOTE: 3

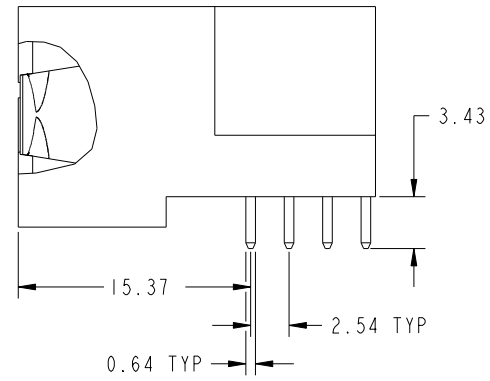

BROKEN-OUT SECTION B-B
SCALE 2:1

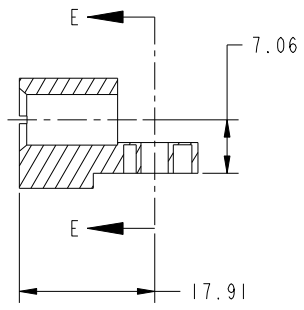

SECTION C-C

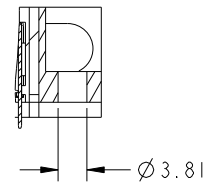

PARTIAL SECTION E-E

dr	GUANG SHI	2012-01-04	projection 	MM ←→	size	A4	scale	1:1
eng	XQ WANG	2012-01-04			ecn no	-		
chr	PM ZHENG	2012-01-04			rel level	Released		
appr	JOSEPH HSIA	2012-01-04	product family	PwrBlade	rev	A		
		title	8ACP RIGHT ANGLE SOLDER HEADER		dwg no	51939-609		
www.fci.com		cat. no.	-		Product - Customer Drw		sheet 2 of 4	



Copyright FCI.

PRODUCT NUMBER

51939-609_
NOTE: 3

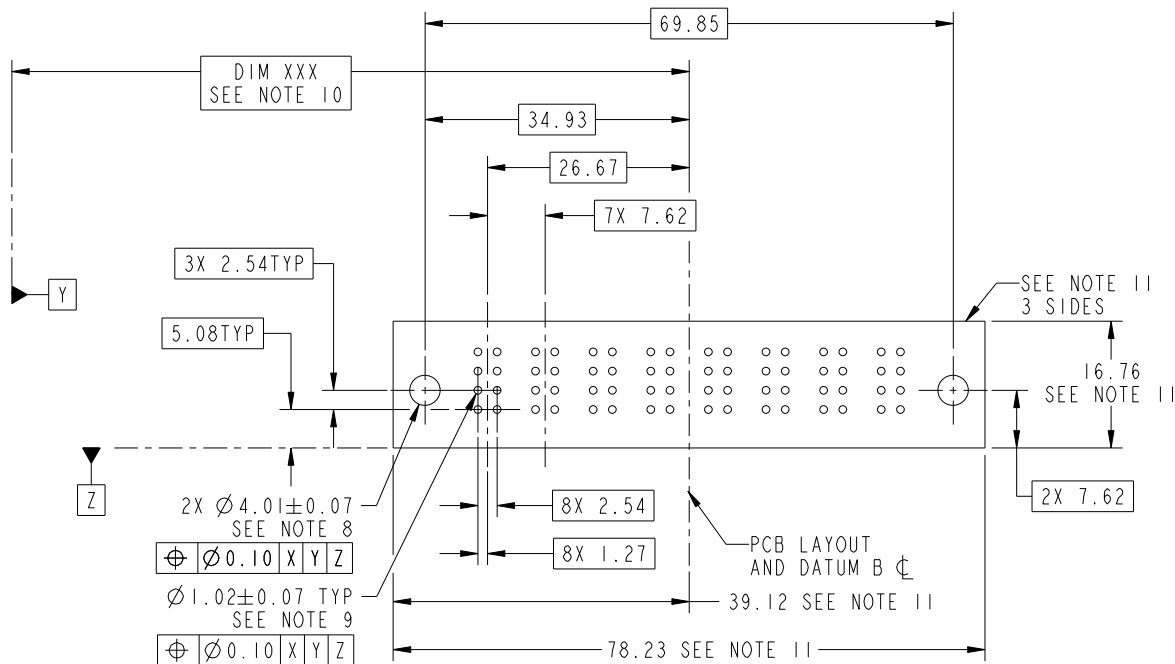

RECOMMENDED PCB LAYOUT

dr	GUANG SHI	2012-01-04	projection 	MM 	size	A4	scale	1:1
eng	XQ WANG	2012-01-04			ecn no	-		
chr	PM ZHENG	2012-01-04			rel level	Released		
appr	JOSEPH HSIA	2012-01-04	product family	PwrBlade	rev	A		
	title	8ACP RIGHT ANGLE SOLDER HEADER		dwg no	51939-609			
www.fci.com	cat. no.	-	Product - Customer Drw		sheet 3 of 4			



PRODUCT NUMBER

51939-609_
NOTE: 3

NOTES:

1. DIMENSIONS AND TOLERANCES ARE IN ACCORDANCE WITH ASME Y14.5M, 1994 UNLESS OTHERWISE SPECIFIED.

CONNECTOR NOTES:

- 2. HOUSING MATERIAL: UL 94 V-0 GLASS FILLED HIGH-TEMP THERMOPLASTIC
POWER CONTACT MATERIAL: COPPER ALLOY
SIGNAL PIN MATERIAL: COPPER ALLOY
- 3. SEE ITEM 1 & 2 IN PRINT 10064183 FOR PLATING SPEC OF 51939-609 AND 51939-609LF RESPECTIVELY.
- 4. MANUFACTURER'S NAME, DATE CODE AND OPTIONAL P/N TO APPEAR ON THIS SURFACE. THE P/N CAN BE OMITTED IF THERE IS NOT ENOUGH SPACE ON THIS SURFACE.
- 5. PRODUCT SPECIFICATION GS-12-149.
APPLICATION SPECIFICATION BUS-20-067.
- 6. PACKAGED IN TRAYS.

PCB NOTES:

- 7. ALL HOLE DIAMETERS ARE FINISHED HOLE SIZE.
- 8. MOUNTING HOLES, WHERE APPLICABLE, ARE UNPLATED.
- 9. $\varnothing 1.151 \pm 0.025$ DRILLED HOLES PLATED WITH
0.008 MIN SnPb OR Sn OVER 0.03
TO 0.08 Cu PLATING TO ACHIEVE
 $\varnothing 1.02 \pm 0.07$ HOLE.
- 10. "DIM XXX" TO BE DETERMINED BY THE CUSTOMER.
- 11. CONNECTOR KEEP-OUT ZONE.

dr	GUANG SHI	2012-01-04	projection 	MM 	size	A4	scale	1:1
eng	XQ WANG	2012-01-04			ecn no	-		
chr	PM ZHENG	2012-01-04			product family	PwrBlade	rel level	Released
appr	JOSEPH HSIA	2012-01-04			rev	A		
		title	8ACP RIGHT ANGLE SOLDER HEADER		dwg no	51939-609		
www.fci.com		cat. no.	-		Product - Customer Drw		sheet 4 of 4	