

Hall effect Unit

SKU:U084



Description

Hall effect Unit integrated with three A3144E Hall sensor switches which are processed by 74HC series gate integrated circuits.

Low-level signal can be generated when the magnet S pole is close to the top of the sensor or the N pole is close to the back, and the internal LED indicator will light up.

It is widely used in applications such as door sensor alarms, proximity sensors, rotation speed measurement and so on. The front side is the North pole, and the low level is output when the south pole signal of the magnetic field is sensed.

Produce Future

- Unipolar Hall switch sensor
- Fast response and high sensitivity
- Status indicator
- Low-level output
- Lego compatible

Include

- 1x Hall effect Unit
- 1x GROVE Cable(20cm)
- 1x Magnet

Application

- Door sensor alarm
- Magnetic field proximity sensing
- Speed measurement

Specification

Specification	Parameter
Hall sensor	A3144E * 3
Logic IC	74HC08D
Status indication	RED LED
Output Level	Active Low
Net weight	4g
Gross weight	17g
Product Size	24*32*8mm
Package Size	67*52*11mm

EasyLoader

EasyLoader is a concise and fast program writer, which has a built-in case program related to the product. It can be burned to the main control by simple steps to perform a series of function verification.

[Download Windows Version Easyloader](#)

[Download MacOS Version Easyloader](#)



Description:

The screen displays the state of magnetic induction, low-level effective

PinMap

M5Core (PORT B)	GPIO26	GPIO36	5V	GND
Hall effect Unit		INPUT	5V	GND

Related Links

- Datasheet
 - [A3144E](#)

Schematic

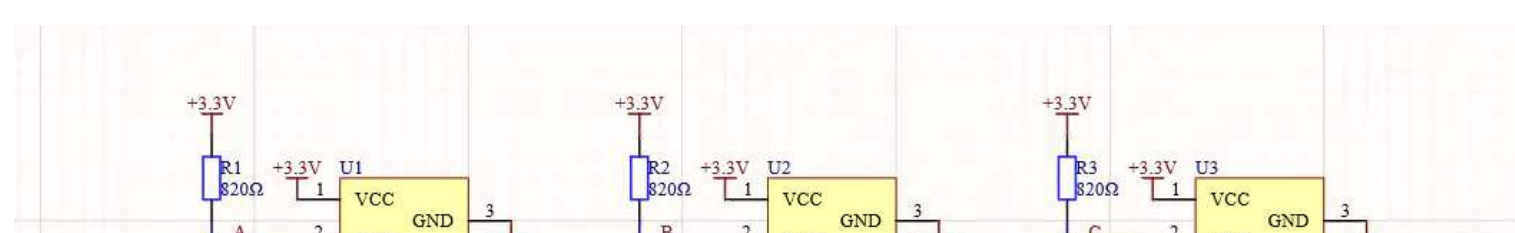

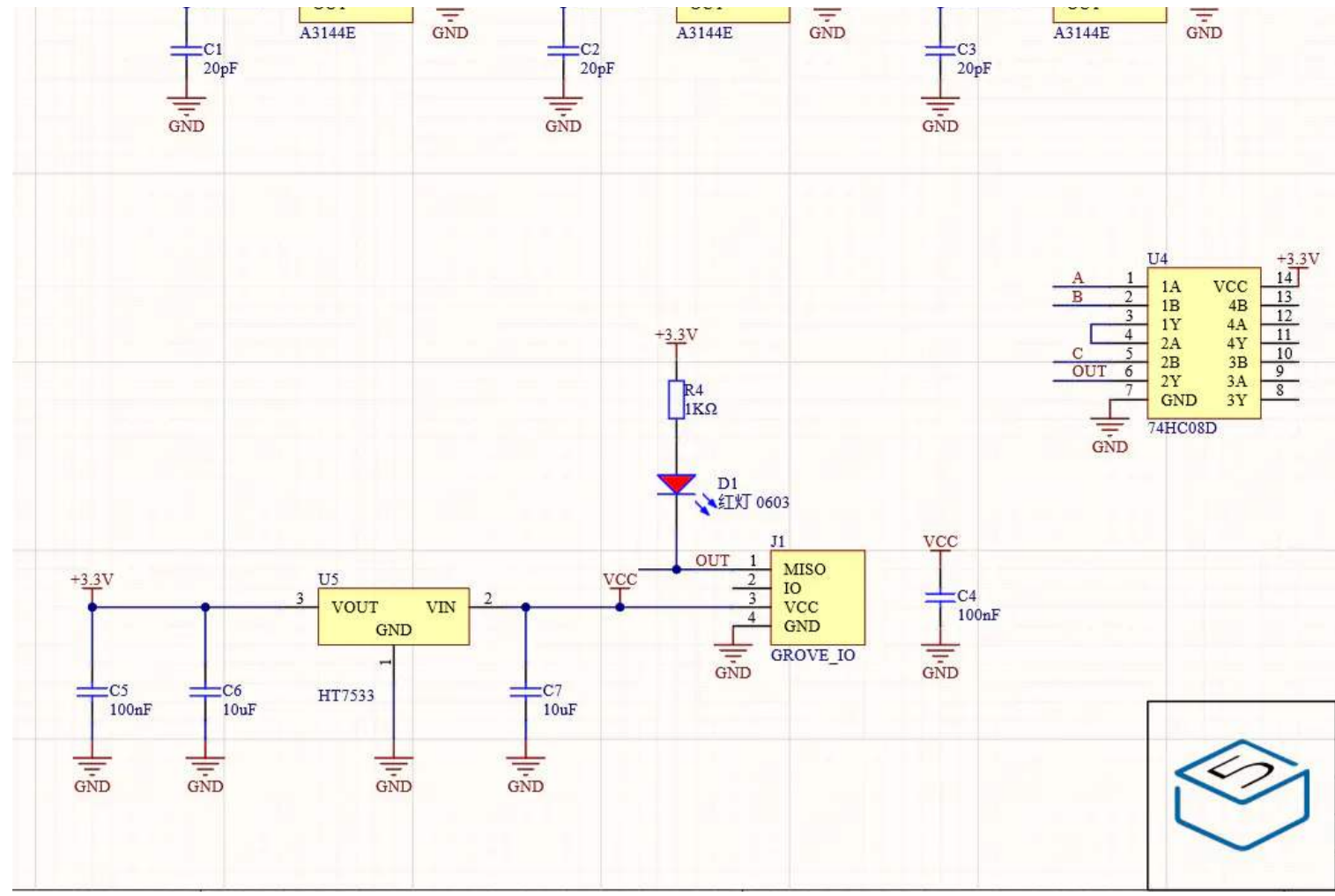

Example

Arduino

- [Click here to download Arduino example.](#)

UIFlow

- [Click here to download UIFlow example.](#)

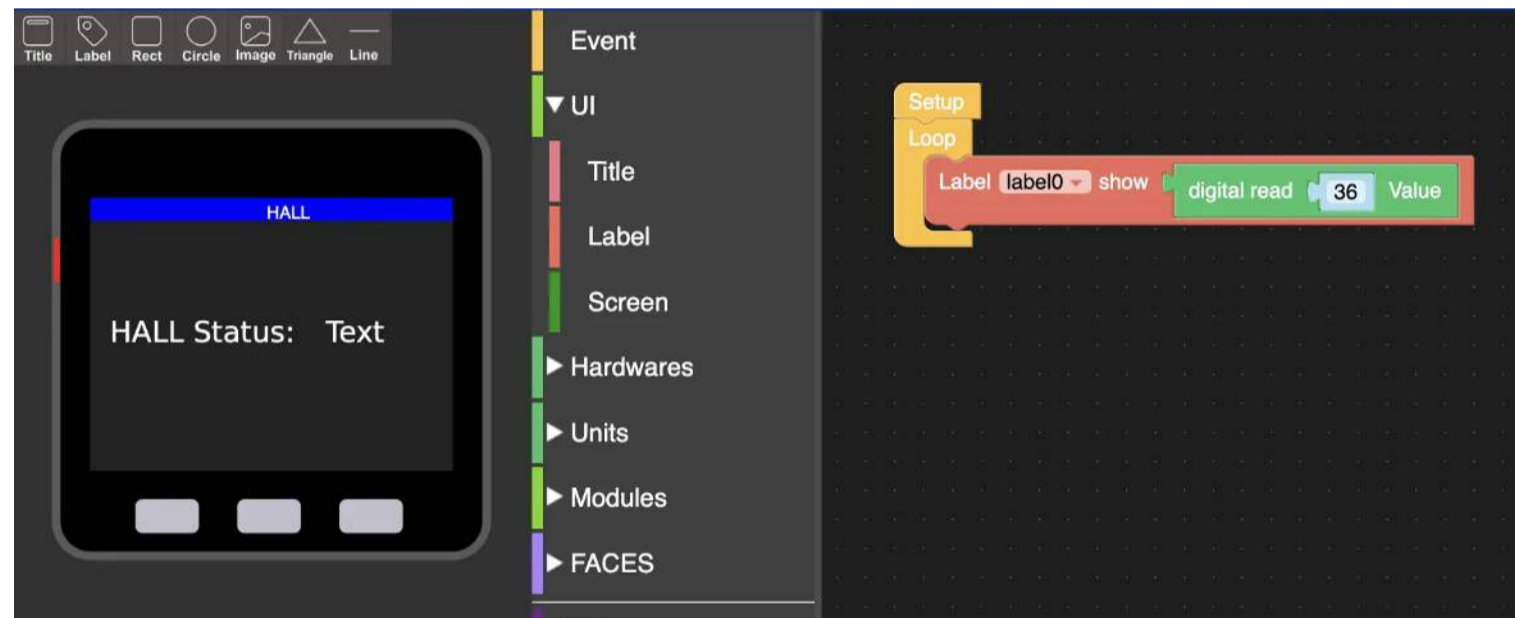

Last updated: 2020-12-11