

# CUSTOMER DRAWING

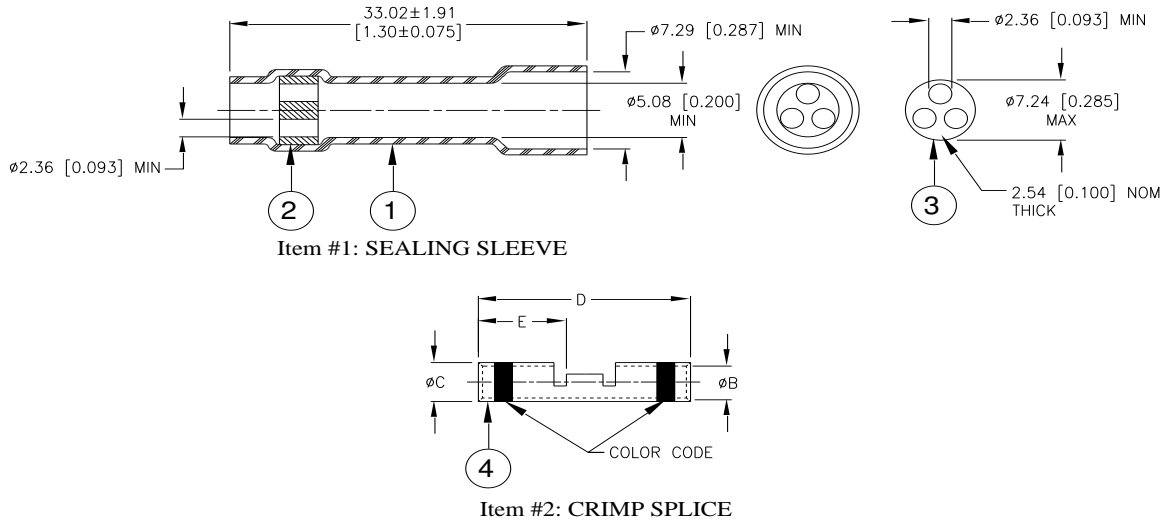

## MATERIALS

1. INSULATION SLEEVE: Heat-shrinkable, transparent blue, radiation cross-linked modified polyvinylidene flouride.
2. INTEGRAL MULTI-WIRE SEAL: Low outgassing immersion resistant thermoplastic fluoroelastomer.  
Color: BLUE.
3. SEPARATE MULTI-WIRE SEAL: Low outgassing immersion resistant thermoplastic fluoroelastomer.  
Color: BLUE.
4. CRIMP SPLICE: Base Metal: Copper Alloy 101 or 102 per ASTM B-75.  
Plating: Nickel per SAE AMS-QQ-N-290.  
Color Code: See table below.

Dimensions:

Part Name	Crimp Splice				
	øB	øC	D	E	Color Code
D-436-88	1.27 [0.050]	2.03 [0.080]	12.95 [0.510]	6.22 [0.245]	Red
	1.14 [0.045]	1.91 [0.075]	12.45 [0.490]	5.72 [0.225]	
D-436-89	1.75 [0.069]	2.70 [0.106]	14.86 [0.585]	7.11 [0.280]	Blue
	1.63 [0.064]	2.57 [0.101]	14.35 [0.565]	6.60 [0.260]	
D-436-90	2.60 [0.102]	3.91 [0.154]	14.86 [0.585]	7.11 [0.280]	Yellow
	2.46 [0.097]	3.73 [0.147]	14.35 [0.565]	6.60 [0.260]	

		<i>Raychem</i> Devices	TITLE: <b>IN-LINE SPLICE SEALING SYSTEM, MULTI-WIRE SPLICER NICKEL PLATED, COLOR CODED, WITH INSPECTION SLOTS</b>		
Unless otherwise specified dimensions are in millimeters. [Inches dimensions are shown in brackets]			DOCUMENT NO.: <b>D-436-88/-90</b>		
TOLERANCES: 0.00 N/A 0.0 N/A 0 N/A	ANGLES: N/A  ROUGHNESS IN MICRON	TE CONNECTIVITY (TE) RESERVES THE RIGHT TO CHANGE THIS DRAWING AT ANYTIME. USER SHOULD EVALUATE THE SUITABILITY OF THE PRODUCT FOR THEIR APPLICATION.	DATE: May 09, 2017	REVISION: <b>C2</b>	
DRAWN BY: M. FORONDA	ECO APPROVED: L. RODRIGUEZ	ECO NUMBER: ECO-17-006515	SCALE: None	SIZE: A	SHEET: 1 of 2

©2015-2017 TE CONNECTIVITY CORPORATION. ALL RIGHTS RESERVED.

If this document is printed it becomes uncontrolled. Check for the latest revision.

# CUSTOMER DRAWING

**Installation Data:**

Part Name	Wire Size Range of Crimp Splice (AWG)			
	Two wires		Three wires	
	Minimum	Maximum	Minimum	Maximum
D-436-88	26	24	28	24
D-436-89	24	20	24	22
D-436-90	22	16	22	18

**MIL Spec equivalent size and wire accomodation:**

Part Name	MIL Spec Equivalent Size	Wire Size Range (AWG)	Wgt. Lbs/Mpc max
D-436-88	M81824/1-1	26 - 20	1.02
D-436-89	M81824/1-2	20 - 16	1.61
D-436-90	M81824/1-3	16 - 12	2.72

**APPLICATION**

1. These parts are designed to provide immersion resistant in-line splices of 2 or 3 to 2 or 3 wires falling within the size range listed on sheet 1, having nickel-plated conductors and insulations rated for at least 135°C.
2. Parts are available only as an assembly of one of each Item #1 and Item #2.
3. Parts are to be installed per assembly procedure as outlined below.
4. Inside diameter and outside diameter of splice are to be measured in crimp area, 2.54 to 5.08mm [0.100 to 0.200in] from ends of part. Slight burr permitted on parted surfaces.
5. Acceptance sampling shall be in accordance with Paragraph 4.6.1 of SAE AS81824.
6. Packing and packaging shall be in accordance with Section 5, Level C, of SAE AS81824.
7. This document takes precedence over documents referenced herein.

**ASSEMBLY PROCEDURE**

**1.0 SCOPE**

This document outlines the procedure to be followed to obtain immersion resistant multiple wire butt splices using Multi-Wire In-Line Splice Sealing system D-436-88/-90.

**2.0 PROCEDURE**

- a) Pass the wires to be attached to one barrel through the separate multi-wire seal (3). Pass the wires to be attached to the other barrel through the sealing sleeve from the three hole insert end.
- b) Strip wires 5/16" to 11/32" and crimp into splice using a Raychem AD-1377 crimp tool. Care must be taken so that the wires remain untwisted between the splice and the separate multi-wire seal (3) or the sealing sleeve cannot be positioned properly.
- c) Position the separate multi-wire seal (3) as close as possible to the splice. Hold this piece in position by squeezing the wires directly behind it, and slide the sealing sleeve over the assembly so that the separate multi-wire seal (3) is as far inside the sleeve as possible.
- d) Apply heat, using the recommended heat source, first to the separate multi-wire seal end, and then to the other. Heat should be applied until insert melts and flows axially along the wire.

**3.0 RECOMMENDED RAYCHEM HEATING TOOLS**

<i>Heater</i>	<i>Reflector</i>	<i>Recommended setting</i>
Steinel HL-2010E	832011-000	316°C-371°C (600°F-700°F)
Heat Gun CV-1981	PR25D	7.5 - 8
Steinel HL-1802E	832011-000	8 - 9

\*Unless otherwise specified, dimensions are in millimeters. [Inches dimensions are shown in rackets]

DOCUMENT NO.: <b>D-436-88/-90</b>	ECO NUMBER: ECO-17-006515	REVISION: C2	DATE: May 09, 2017	SHEET: 2 of 2
--------------------------------------	------------------------------	-----------------	-----------------------	------------------

©2015-2017 TE CORPORATION. ALL RIGHTS RESERVED.

If this document is printed it becomes uncontrolled. Check for the latest revision.