

PRODUCT SPECIFICATION

Part Number	MEM2061	Rev	A	Date	01/06/15		
Product Description	Micro SD Memory Card Connector, Push-Push, SMT, Card Entry Normal, 1.88mm Profile.			Page	1		
Doc Number	MEM2061	Prepared	AO	Checked	VJ	Approved	ST

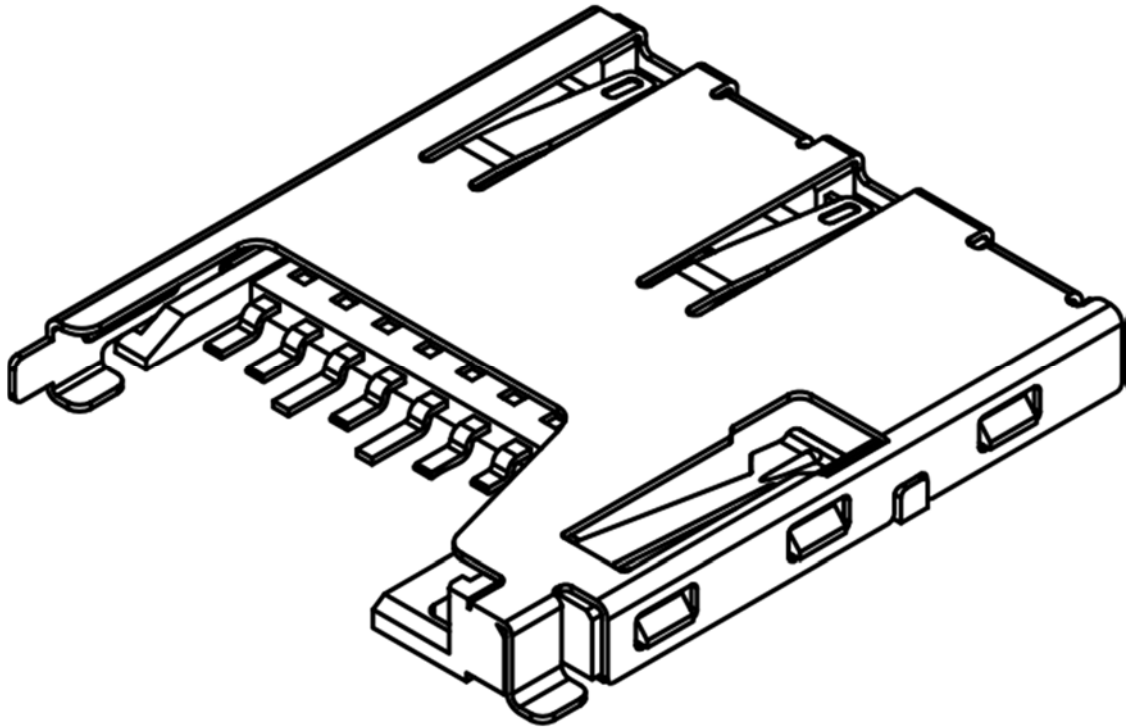

PRODUCT SPECIFICATION

Part Number	MEM2061	Rev	A	Date	01/06/15		
Product Description	Micro SD Memory Card Connector, Push-Push, SMT, Card Entry Normal, 1.88mm Profile.			Page	2		
Doc Number	MEM2061	Prepared	AO	Checked	VJ	Approved	ST

1.0 SCOPE.

This specification covers performance, test and quality requirements for the Micro SD Memory Card Connector Normally open MEM 2061 (Push-Push Type, SMT, 1.88mm Profile.).

2.0 PRODUCT NAME AND PART NUMBER.

Memory Card Connector, Push-Push Type: MEM2061.

3.0 PRODUCT SHAPE, DIMENSIONS AND MATERIAL.

Please refer to drawings.

4.0 RATINGS.

- 4.1 Current rating 0.5A DC (per pin)
- 4.2 Voltage rating 100 Volts AC(RMS)
- 4.3 Operating Temperature Range -25°C TO +85°C

5.0 TEST AND MEASUREMENT CONDITIONS.

Product is designed to meet electrical, mechanical and environmental performance requirements specified in Paragraph 6.0. All tests are performed in ambient conditions unless otherwise specified.

6.0 PERFORMANCE.

Item	Test Condition	Requirement
Examination of Product	Visual, dimensional and functional inspection as per quality plan.	Product shall meet requirements of product drawing and specification.

PRODUCT SPECIFICATION

Part Number	MEM2061	Rev	A	Date	01/06/15
Product Description	Micro SD Memory Card Connector, Push-Push, SMT, Card Entry Normal, 1.88mm Profile.			Page	3
Doc Number	MEM2061	Prepared	AO	Checked	VJ
				Approved	ST

6.1 Electrical Performance.

Item	Test Condition	Requirement
Contact Resistance	Measure and record contact resistance of mated connector using test current of 10mA max and 20 mV open circuit voltage in accordance with EIA-364-6B.	Less than 80 mΩ initial Less than 100 mΩ at end of test
Insulation Resistance	Apply 500Volts DC between adjacent contacts of mated connectors for one minute in accordance with EIA-364-21C	Greater than 500 MΩ
Dielectric Strength	Mate connectors and apply 500 V AC for 1 minute between adjacent terminal ground, in accordance with EIA-364-20B.	No creeping discharge or flash over. Current leakage less than 1.0 mA

6.2 Mechanical Performance.

Item	Test Condition	Requirement
Card Retention Force	Pull the card at speed of 25mm/min.	Initial value 0.8N minimum.
Insertion/Ejection Force	Push the card at speed of 25+/- 3mm/minute.	Lock Force: 10N (1.02 kgf) Max. Lock Release Force: 10N (1.02 kgf) Max.
Durability	The connector should be mated and unmated for 5000 cycles with 0.6mm travel at a rate of 25mm/min.	No evidence of physical damage. Contact Resistance $\leq 100m\Omega$ at end of test .
Vibration	Subject mated connectors to 10 to 55 to 10 Hz frequency span over 1 minute at a 1.5mm amplitude. Test to be conducted on 3 mutually perpendicular planes for 15 minutes each with 100mA applied and in accordance with EIA-364-28D.	No electrical discontinuity greater than 1 μ sec. shall occur. No damage to product. Contact Resistance $\leq 100m\Omega$ at end of test .
Mechanical Shock	Subject the part to a 294 m/s ² half sine wave acceleration for 11 ms. Three shocks to be applied in each of the X, Y and Z planes and in both directions. A total of 18 shocks. Apply DC 1 mA current during test in accordance with EIA-364-27B.	No electrical discontinuity greater than 1 μ sec. shall occur. No damage to product. Contact Resistance $\leq 100m\Omega$ at end of test .

PRODUCT SPECIFICATION

Part Number	MEM2061	Rev	A	Date	01/06/15
Product Description	Micro SD Memory Card Connector, Push-Push, SMT, Card Entry Normal, 1.88mm Profile.			Page	4
Doc Number	MEM2061	Prepared	AO	Checked	VJ
				Approved	ST

6.3 Environmental Performance and Others.

Item	Test Condition	Requirement
Thermal Shock	Mate Connector and perform the following thermal cycle :- -55+/-3°C for 30 minutes. . +85+/-2°C for 30 minutes. Repeat for 5 cycles in accordance with EIA-364-32C.	No evidence of physical damage, discharge, flashes or corrosion in contact areas. Contact Resistance Less than 100mΩ at end of test. Insulation Resistance greater than 1000Ω at end of test.
Humidity Test	Mate connector and expose to temperature of 40±2°C with 95% RH for 96 hours then place in ambient temperature for 1 to 2 hrs. In accordance with EIA-364-31 method III test condition A.	
Salt Water Spray	Subject mated connectors to 35±2°C and 5±1% salt condition for 48hours. Test in accordance with EIA-364-26B.	
Temperature Life (High)	Subject product to 85±2°C for 96 hours continuously in accordance with MIL-STD-202, Method 108.	
Solderability	Dip solders tails into molten solder, held at a temperature of 245±5°C for 5±0.5 seconds, in accordance with EIA-364-52.	
Resistance to Reflow Soldering Heat.	Mount connector, place in reflow oven and expose to the temperature profile shown in fig 1.0	

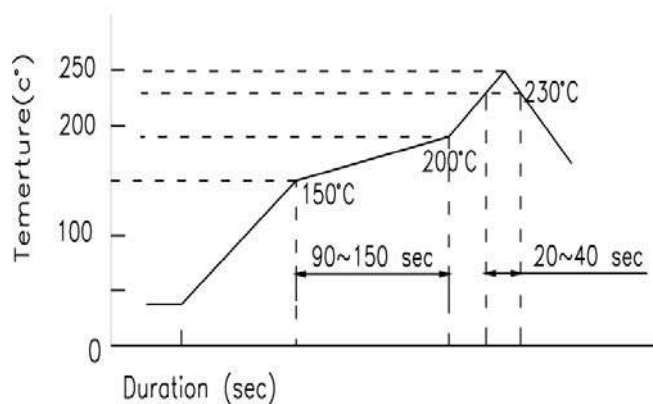

Fig.1. Recommended Reflow Temp. Profile

PRODUCT SPECIFICATION

Part Number	MEM2061	Rev	A	Date	01/06/15		
Product Description	Micro SD Memory Card Connector, Push-Push, SMT, Card Entry Normal, 1.88mm Profile.			Page	5		
Doc Number	MEM2061	Prepared	AO	Checked	VJ	Approved	ST

7.0 PRODUCT QUALIFICATION AND TEST SEQUENCE

Test Item	Group						
	A	B	C	D	E	F	G
Examination of Product	1,7	1,10	1,100	1,5	1,5	1,3	1,3
Contact Resistance	3,6	2,7	2,7	2,4	2,4		
Insulation Resistance		3,8	3,8				
Dielectric Withstanding Voltage		4,9	4,9				
Mechanical shock		6					
Card Retention Force	2,5						
Insertion/Ejection Force	2,5						
Durability	4						
Vibration		5					
Humidity			6				
Salt Water Spray				3			
Temperature Life					3		
Thermal Shock			5				
Solderability						2	
Resistance to Reflow Soldering heat							2
Sample QTY.	5	5	5	5	5	5	5