

Property of LITE-ON Only

Features

- * Package in 8mm tape on 7" diameter reels.
- * Compatible with automatic placement equipment.
- * Compatible with infrared and vapor phase reflow solder process.
- * EIA STD package.
- * I.C. compatible.

Package Dimensions

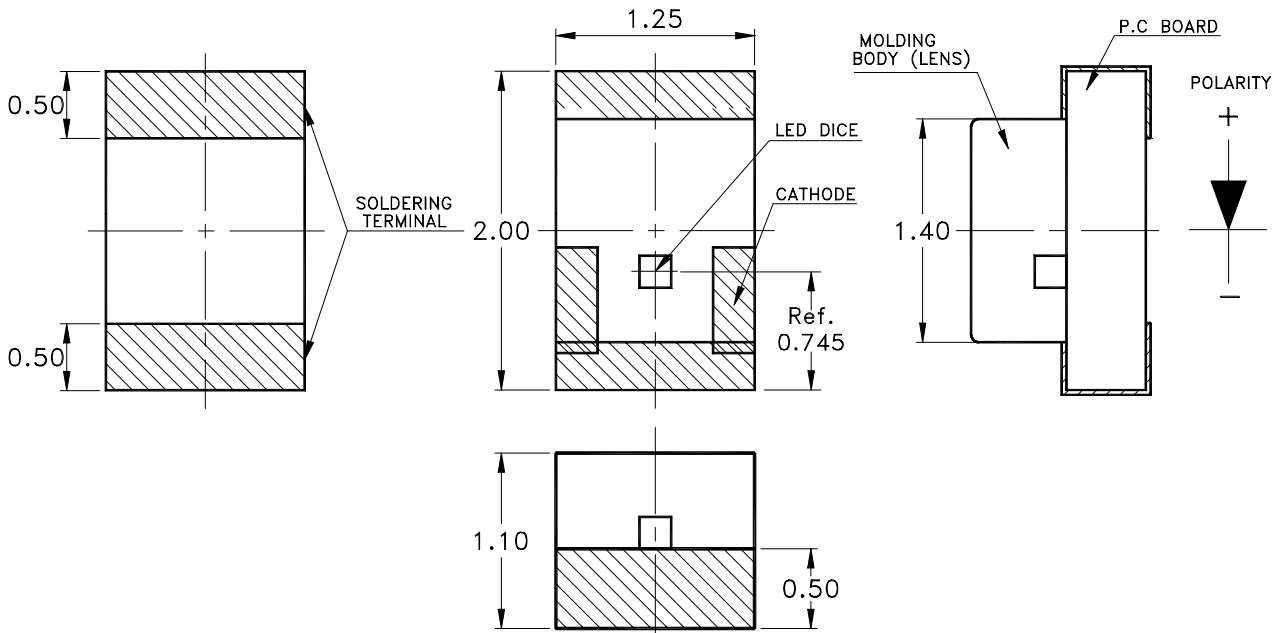

| Part no. | Lens | Source Color |
|--------------|-------------|------------------|
| LTST-C170EKT | Water Clear | GaAsP on GaP Red |

Notes:

1. All dimensions are in millimeters (inches).
2. Tolerance is $\pm 0.1\text{mm}$ (.004") unless otherwise noted.

Property of LITE-ON Only

Absolute Maximum Ratings At Ta=25°C

| Parameter | LTST-C170EKT | Unit |
|--|---------------------|-------|
| Power Dissipation | 100 | mW |
| Peak Forward Current (1/10 Duty Cycle, 0.1ms Pulse Width) | 120 | mA |
| Continuous Forward Current | 30 | mA |
| Derating Linear From 50°C | 0.6 | mA/°C |
| Reverse Voltage | 5 | V |
| Operating Temperature Range | -55°C to + 85°C | |
| Storage Temperature Range | -55°C to + 85°C | |
| Wave Soldering Condition | 260°C For 5 Seconds | |
| Infrared Soldering Condition | 260°C For 5 Seconds | |
| Vapor Phase Soldering Condition | 215°C For 3 Minutes | |

Suggest IR Reflow Condition :

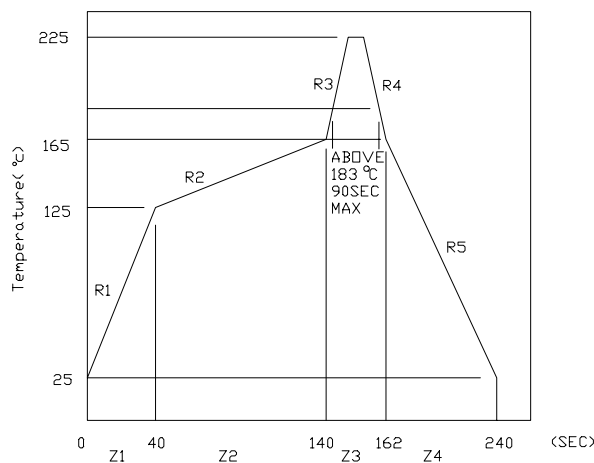

Property of LITE-ON Only

Electrical Optical Characteristics At Ta=25°C

| Parameter | Symbol | Part No. LTST- | Min. | Typ. | Max. | Unit | Test Condition |
|--------------------------|--------|-------------------|------|------|------|------|------------------------------|
| Luminous Intensity | IV | C170EKT | 1.0 | 2.0 | | mcd | IF = 10mA Note 1 |
| Viewing Angle | 2θ 1/2 | C170EKT | | 130 | | deg | Note 2 (Fig.6) |
| Peak Emission Wavelength | λ Peak | C170EKT | | 630 | | nm | Measurement @Peak (Fig.1) |
| Dominant Wavelength | λ d | C170EKT | | 621 | | nm | Note 3 |
| Spectral Line Half-Width | Δ λ | C170EKT | | 24 | | nm | |
| Forward Voltage | VF | C170EKT | | 2.0 | 2.6 | V | IF = 20mA |
| Reverse Current | IR | C170EKT | | | 100 | μ A | VR = 5V |
| Capacitance | C | C170EKT | | 20 | | PF | VF = 0 f = 1MHZ |

Notes: 1. Luminous intensity is measured with a light sensor and filter combination that approximates the CIE eye-response curve.

2. θ 1/2 is the off-axis angle at which the luminous intensity is half the axial luminous intensity.

3. The dominant wavelength, λ d is derived from the CIE chromaticity diagram and represents the single wavelength which defines the color of the device.



Bin Code List

| Luminous Intensity | | Unit : mcd @10mA |
|--------------------|------|------------------|
| Bin Code | Min. | Max. |
| F | 1.0 | 2.0 |
| G | 1.6 | 3.2 |
| H | 2.5 | 5.0 |
| J | 4.0 | 8.0 |
| K | 6.3 | 12.5 |

Property of LITE-ON Only

Typical Electrical / Optical Characteristics Curves (25°C Ambient Temperature Unless Otherwise Noted)

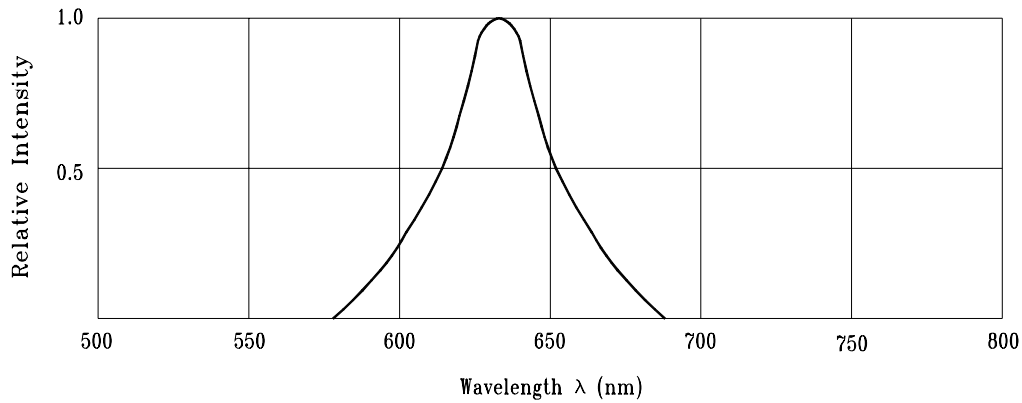

Fig.1 RELATIVE INTENSITY VS. WAVELENGTH

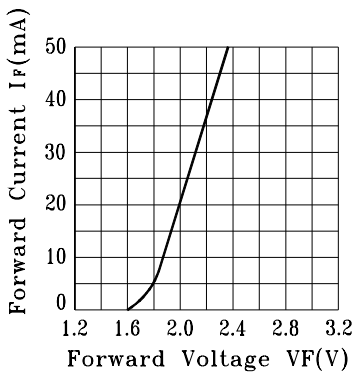

Fig.2 FORWARD CURRENT VS. FORWARD VOLTAGE

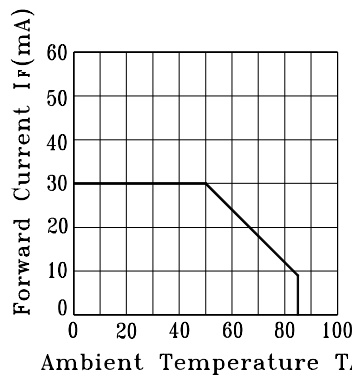

Fig.3 FORWARD CURRENT DERATING CURVE

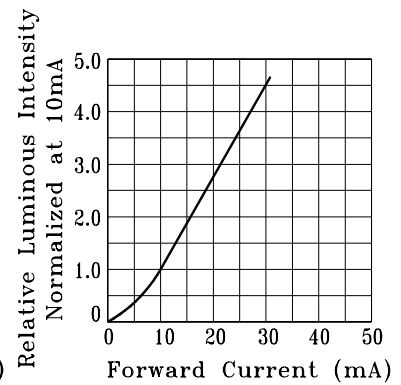

Fig.4 RELATIVE LUMINOUS INTENSITY VS. FORWARD CURRENT

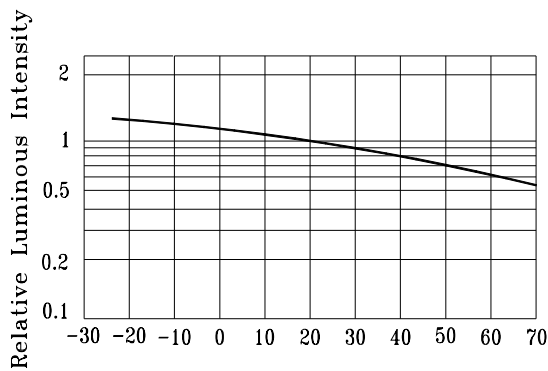

Fig.5 LUMINOUS INTENSITY VS. AMBIENT TEMPERATURE.

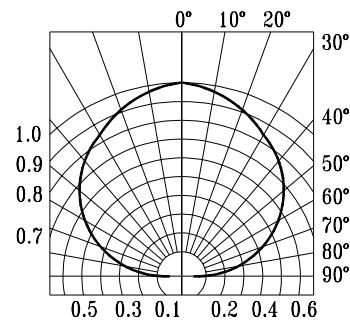

Fig.6 SPATIAL DISTRIBUTION

Property of LITE-ON Only

Cleaning

Do not use unspecified chemical liquid to clean LED they could harm the package.
If clean is necessary, immerse the LED in ethyl alcohol or in isopropyl alcohol at normal temperature for less one minute.

Suggest Soldering Pad Dimensions

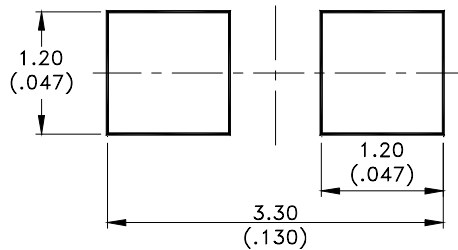

Package Dimensions Of Tape And Reel

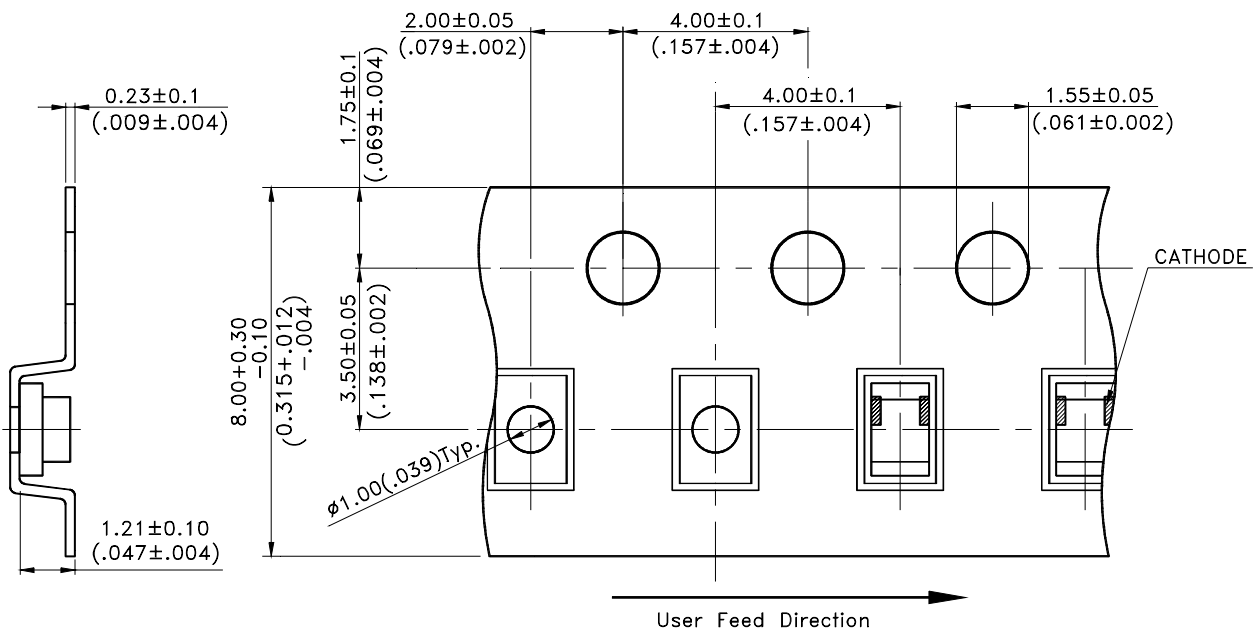

Notes:

1. All dimensions are in millimeters (inches).

Property of LITE-ON Only

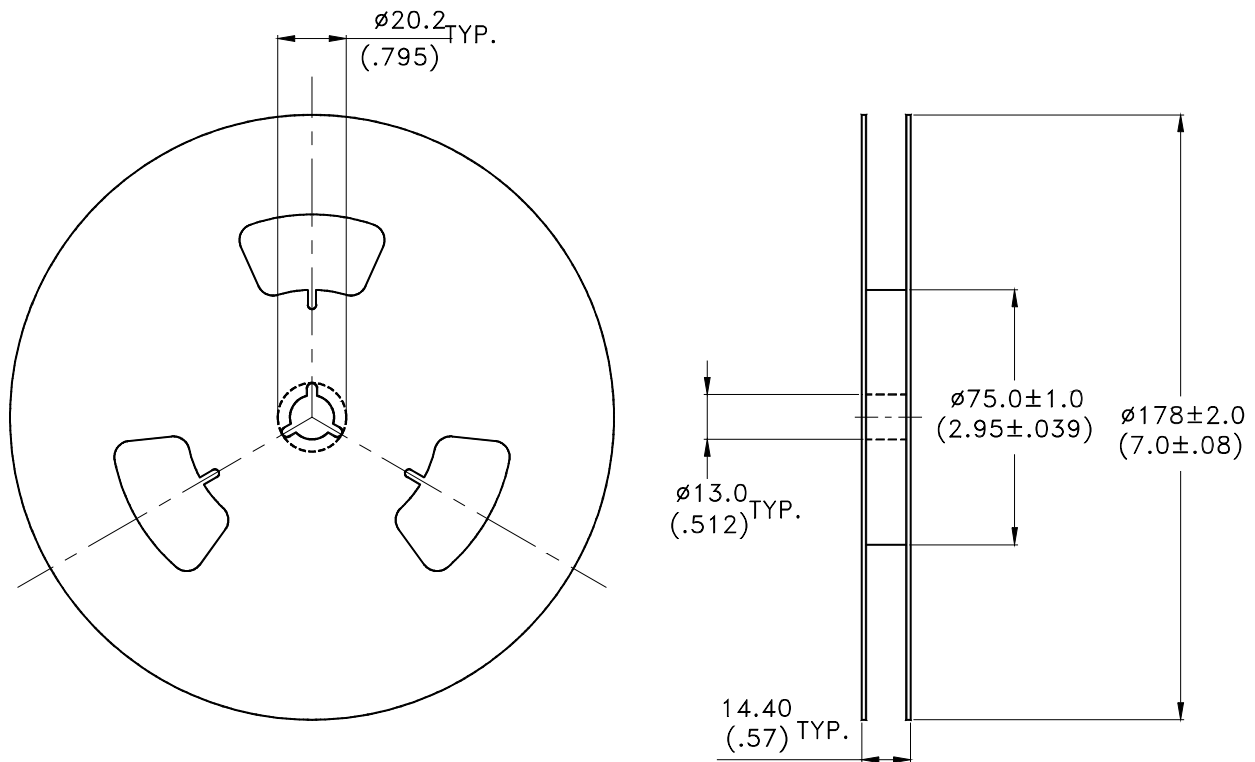

Notes:

1. Empty component pockets sealed with top cover tape.
2. 7 inch reel-3000 pieces per reel.
3. The maximum number of consecutive missing lamps is two.
4. In accordance with ANSI/EIA 481-1-A-1994 specifications.