

Chip Inductor AWVI Series

**Automotive
AEC-Q200**

RoHS Compliant
Halogen Free
REACH Compliant

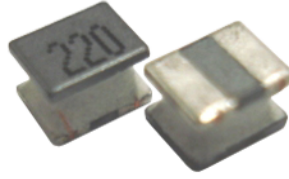

- RF
Circuit
- Unshield
- Wire
Wound
- Ferrite
- General
Signal line

Part Numbering

A	WVI	00	322522	3R3	K	H0
Grade	Series Name	Control Code	Dimensions Code (mm)	Inductance (uH)	Tolerance	Internal Code
			322522 3.2x2.5x2	3R3 3.3 100 10	K ±10% J ±5%	

AWVI00322522 Type

■ Dimensions

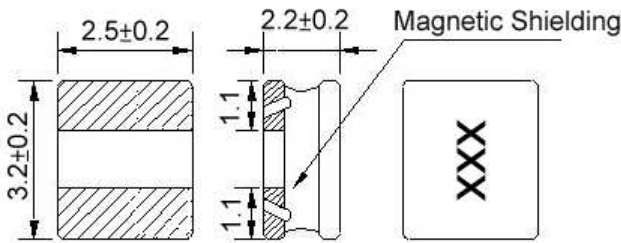

unit:mm

■ Recommended Land Pattern

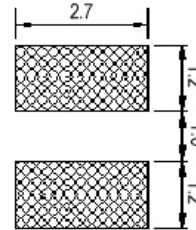

unit:mm

■ Electrical Characteristics

Part No.	Inductance (uH)	Test Freq. (MHz)	Q Min.	SRF (MHz)Min.	RDC (Ω)Max.	I _{rms} (mA)Max.	Tolerance (±%)	ng
AWVI003225223R3JH0	3.3	7.96/2.52	10	45	0.18	770	5,10	3R3
AWVI003225224R7JH0	4.7	7.96/2.52	10	40	0.25	700	5,10	4R7
AWVI00322522100JH0	10	2.52/2.52	12	25	0.46	500	5,10	100
AWVI00322522220JH0	22	2.52/2.52	12	14	1.0	330	5,10	220
AWVI00322522330JH0	33	2.52/2.52	15	10	1.4	280	5,10	330
AWVI00322522470JH0	47	2.52/2.52	15	8.0	2.1	230	5,10	470

Note: When ordering, please specify tolerance code. Tolerance: J=±5% / K=±10%

1. Operating temperature range - 40°C ~ 125°C
2. I_{rms} for a 15°C temperature rise from 25°C ambient with current
4. Measure Equipment:
 L & Q: Agilent E4991A (over 1MHz)+Agilent HP16197A/Agilent HP4285A (under 1MHz)
 SRF: Agilent E4991A+Agilent HP16197A or equivalent
 RDC: DIGITAL MILLINHM METER CHROMA 16502
 I_{rms}: HP4285A+HP42841A

AWVI00322522 Type

Characteristics Graph

Inductance vs. Frequency Characteristics

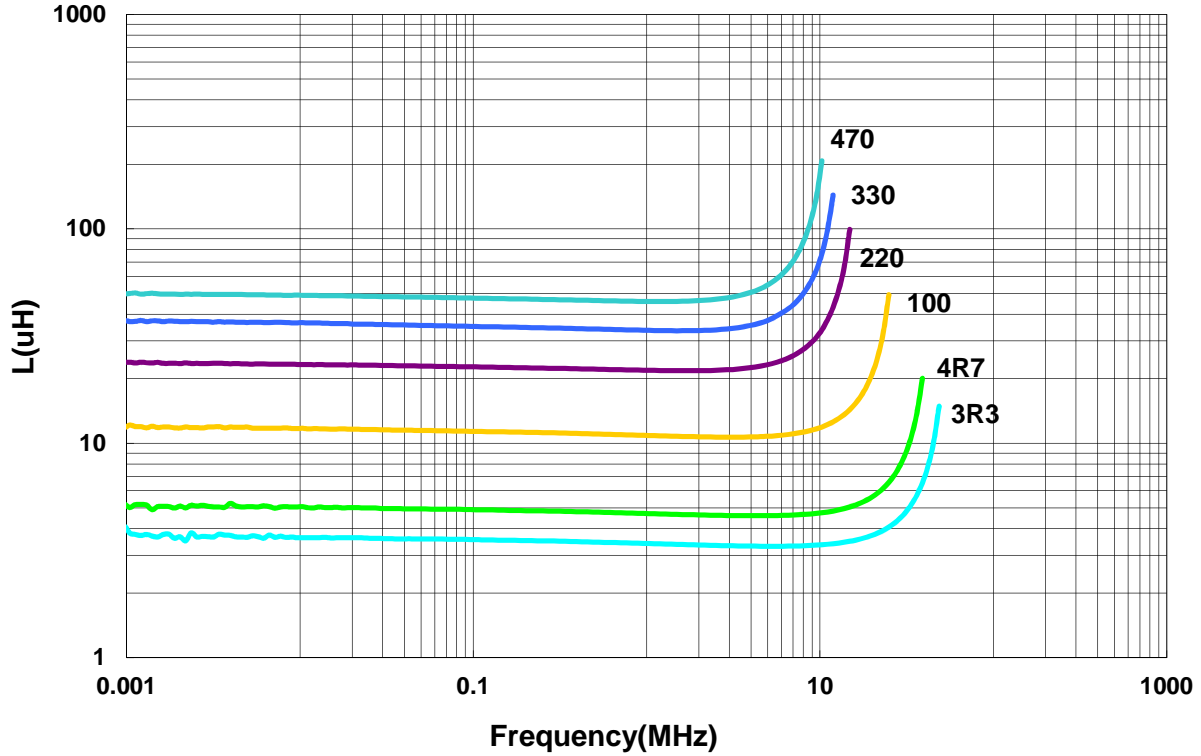

Frequency vs. Q

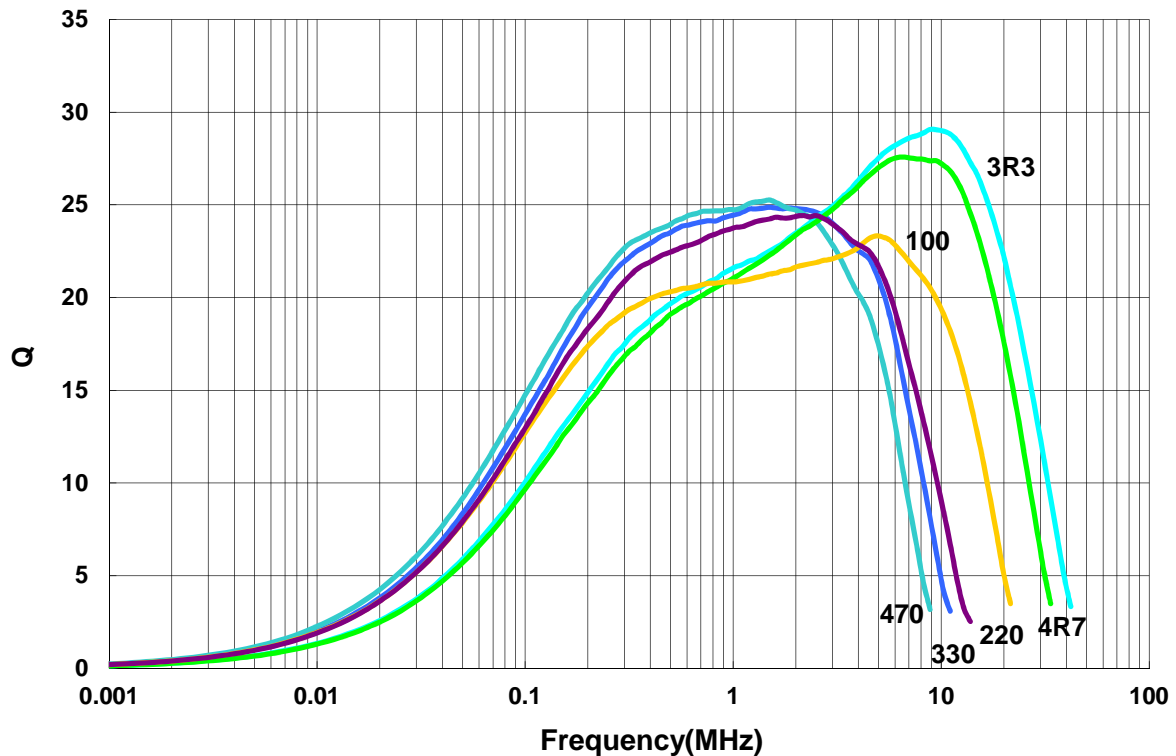

Please be sure to request approval specifications that provide further details of the products. Kindly note that the content of these specifications are subject to change or may be discontinued without prior notice. This product may not be designed/used in medical or high risk applications without Chilisin approval. Please contact our sales department before ordering.

■ Packaging

Tape Dimensions

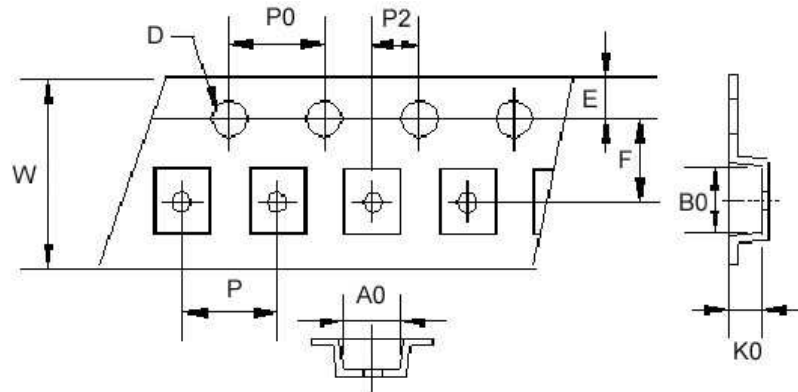

Reel Dimensions

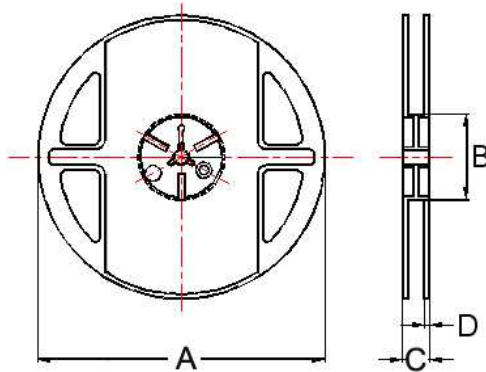

Dimensions in mm

TYPE	Tape Dimensions											Reel Dimensions				Quantity
	A0	B0	K0	D	E	F	W	P	P0	P2	A	B	C	D	PCS / Reel	
AWVI00322522	2.8	3.4	2.4	1.5	1.75	3.5	8	4	4	2	178	60	12	1.5	1000	