

PAGE 1/3	ISSUE 19-10-15W	SERIES C	<b>PART NUMBER R166018000</b>
----------	-----------------	----------	-------------------------------

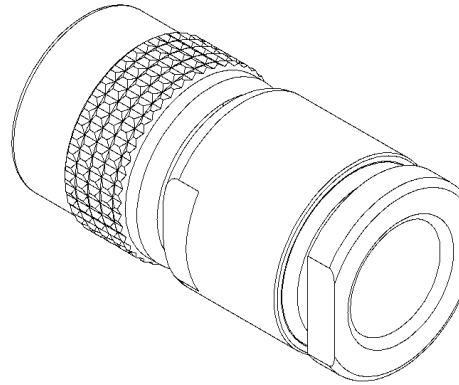

All dimensions are in mm.

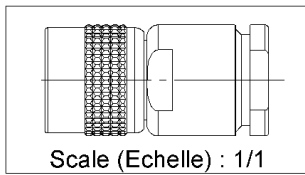
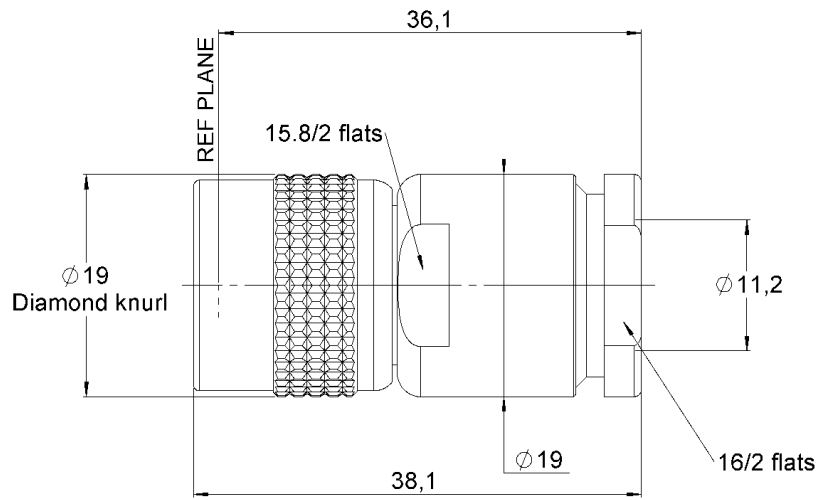

COMPONENTS	MATERIALS	PLATING (µm)
Body	<b>BRASS.</b>	<b>NICKEL 2</b>
Center contact	<b>BRASS.</b>	<b>GOLD 0.5 OVER NICKEL 2</b>
Outer contact	<b>BRONZE</b>	<b>NICKEL 2</b>
Insulator	<b>PTFE</b>	
Gasket	<b>SILICONE</b>	
Others parts	<b>BRASS.</b>	<b>NICKEL 2</b>
-	-	-
-	-	-

PAGE 2/3	ISSUE 19-10-15W	SERIES C	PART NUMBER R166018000
----------	-----------------	----------	------------------------

### PACKAGING

Standard	Unit	Other
1	Contact us	Contact us

### ELECTRICAL CHARACTERISTICS

Impedance	50	Ω
Frequency	0-11	GHz
VSWR	1.2 + 0,0000	x F(GHz) Maxi
Insertion loss	0.05	√F(GHz) dB Maxi
RF leakage	- ( NA	- F(GHz)) dB Maxi
Voltage rating	1000	Veff Maxi
Dielectric withstanding voltage	3000	Veff mini
Insulation resistance	5000	MΩ mini

### MECHANICAL CHARACTERISTICS

Center contact retention		
Axial force – Mating End	NA	N mini
Axial force – Opposite end	NA	N mini
Torque	NA	N.cm mini
Recommended torque		
Mating	NA	N.cm
Panel nut	NA	N.cm
Clamp nut	800	N.cm
A/F clamp nut	16,0000	mm
Mating life	500	Cycles mini
Weight	44,1000	g

### ENVIRONMENTAL

Operating temperature	-55/+155	°C
Hermetic seal	NA	Atm.cm3/s
Panel leakage	NA	

### SPECIFICATION

### CABLE ASSEMBLY

Stripping	a	b	c	d	e	f
mm	4	7,5	0	0	1,5	0

Assembly instruction: **Clamp 02**

Recommended cable(s)

- KX 4**
- KX 13**
- KX 24**
- RG 213**
- RG 225**
- RG 214**
- RG 165**

Characteristics indicated on this data sheet are those that can be achieved with the highest performance cable. Intrinsic limitations of the cable may diminish the performance of the assembly

Cable retention

- pull off	300	N mini
- torque	NA	N.cm

### TOOLING

Part Number	Description	Hexagon
.	.	.

### OTHER CHARACTERISTICS

-

PAGE 3/3	ISSUE 19-10-15W	SERIES C	PART NUMBER <b>R166018000</b>
----------	-----------------	----------	-------------------------------

**COMPONENTS**

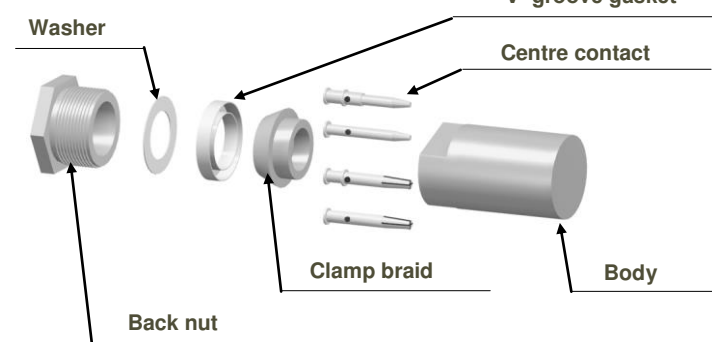

**STRIPPING DIMENSIONS**

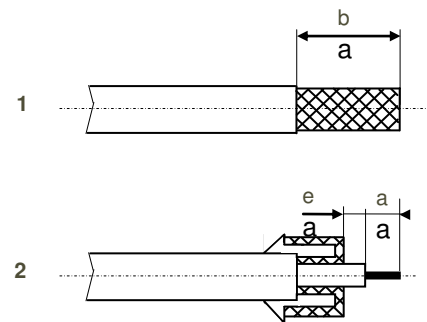

**1**

Strip the cable as shown in sketch 1.

**4**

Slide the back nut over the cable assembly. Slide the centre contact onto the inner conductor.

**2**

Slide the back nut, the washer and the 'V' groove gasket onto the cable. Slide the clamp braid sleeve over the braid.

**5**

Solder the centre contact onto the inner conductor.

**3**

Fold the braid back and trim off the extra braid. Trim dielectric back as shown in sketch 2.

**6**

Screw sub-assembly into the connector body with the adapted wrench. Recommended coupling torque ( see connector TDS ).