



**Product Family:** 2-Terminal Low Ohm Current Sense Resistors

**Part Number Series:** D1WEL Series



	<p><b>Construction:</b></p> <ul style="list-style-type: none"> <li>• High purity alumina substrate</li> <li>• Metal foil resistive element</li> <li>• Epoxy-resin overcoat</li> <li>• Wrap around electrodes</li> <li>• 100% matte tin over Ni terminations</li> <li>• RoHS complainant and Pb free</li> <li>• Inherently Anti-Sulfur</li> </ul>	<p><b>Features:</b></p> <ul style="list-style-type: none"> <li>• TCR down to <math>\pm 50</math> ppm/<math>^{\circ}</math>C</li> <li>• Resistances from <math>1\text{m}\Omega</math> ~ <math>700\text{m}\Omega</math></li> <li>• Optimal linearity in I/V conversion</li> <li>• High volume production suitable for commercial and special applications</li> <li>• Competitive pricing</li> <li>• Moisture Sensitivity Level = 1</li> <li>• AEC-Q200 qualified</li> </ul>
--	--	---

**Description:**

These low ohm current sense resistors are designed for tight resistance tolerance, low noise, long-term stability and high heat dissipation capability in a small package. This series is ideal for use in power management modules, motor control circuits and automotive applications.

**Product Construction:**

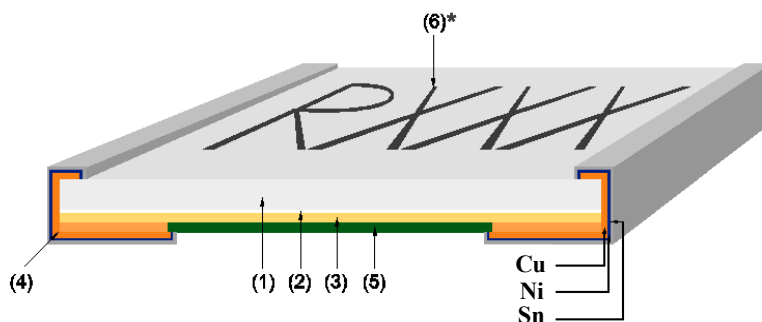

Number	Description
1	Substrate (Alumina Ceramic)
2	Adhesion Layer (Epoxy)
3	Resistive Element (Cu Alloy Foil)
4	Terminal Electrode (Cu, Ni, Sn)
5	Protective Coating (Flame-retardant epoxy, UL-94-V0)
6	Marking* (Flame-retardant epoxy, UL-94-V0)

\* Note: Marking is 2 digits (XX) for 0603 case size, 3 digits (XXX) for 0805 and 0508 case sizes, and 4 digits (RXXX) for all other case sizes.

**Part Numbering:** Ex: D1WEL0508MR010F-T5

Series Name	English Size	Material	Resistance Range	Resistance Tolerance	Automotive Grade	T&R Packaging Quantity
D1WEL	(Refer to "type" in electrical tables)	M	Ex. R010 = 10mΩ R100 = 100mΩ (Refer to tables)	D = $\pm 0.5\%$ * F = $\pm 1.0\%$  (refer to tables)	A = AEC-Q200 Leave Blank for Non AEC-Q200	-T1 = 1,000 pcs/reel -T2 = 2,000 pcs/reel -T4 = 4,000 pcs/reel -T5 = 5,000 pcs/reel (Refer to tables)

\* Note:  $\pm 0.5\%$  (D) tolerance is not available for all resistance values. See electrical specifications table.

**Product Dimensions:**

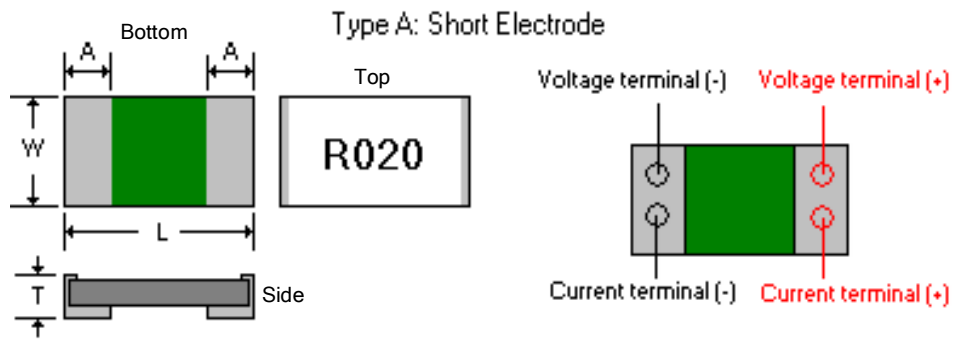

All dimensions in inches, mm in parentheses.

Dimension (Metric)	Electrode Type	Resistance Range	L	W	A	T
D1WEL0603 (1608)	A	5mΩ	0.067 ±0.008 (1.70 ±0.20)	0.035 ±0.008 (0.90 ±0.20)	0.020 ±0.008 (0.50 ±0.20)	0.026 ±0.008 (0.65 ±0.15)
		6mΩ~100mΩ			0.016 ±0.008 (0.40 ±0.20)	
D1WEL0805 (2012)	A	3mΩ	0.083 ±0.008 (2.10 ±0.20)	0.053 ±0.008 (1.35 ±0.20)	0.026 ±0.008 (0.65 ±0.20)	0.026 ±0.008 (0.65 ±0.20)
		4mΩ~500mΩ			0.020 ±0.008 (0.50 ±0.20)	
D1WEL1206 (3216)	A	3mΩ	0.130 ±0.008 (3.30 ±0.20)	0.067 ±0.008 (1.70 ±0.20)	0.047 ±0.012 (1.20 ±0.30)	0.026 ±0.008 (0.65 ±0.20)
		4mΩ~700mΩ			0.027 ±0.012 (0.68 ±0.30)	
D1WEL2010 (5025)	A	2mΩ~3mΩ	0.201 ±0.008 (5.10 ±0.20)	0.102 ±0.008 (2.60 ±0.20)	0.083 ±0.012 (2.10 ±0.30)	0.026 ±0.008 (0.65 ±0.20)
		4mΩ~700mΩ			0.028 ±0.012 (0.70 ±0.30)	
D1WEL2512 (6432)	A	2mΩ	0.252 ±0.012 (6.40 ±0.30)	0.126 ±0.012 (3.20 ±0.30)	0.110 ±0.012 (2.80 ±0.30)	0.026 ±0.008 (0.65 ±0.20)
		3mΩ			0.102 ±0.012 (2.60 ±0.30)	
		4mΩ~700mΩ			0.041 ±0.012 (1.05 ±0.30)	
D1WEL4320 (11050)	A	2mΩ	0.437 ±0.012 (11.1 ±0.30)	0.201 ±0.012 (5.10 ±0.30)	0.193 ±0.012 (4.90 ±0.30)	0.026 ±0.008 (0.65 ±0.20)
		3mΩ			0.179 ±0.012 (4.55 ±0.30)	
		4mΩ~100mΩ			0.093 ±0.012 (2.36 ±0.30)	
D1WEL4527 (11470)	A	2mΩ	0.457 ±0.039 (11.6 ±1.00)	0.279 ±0.039 (7.10 ±1.00)	0.197 ±0.016 (5.00 ±0.40)	0.026 ±0.008 (0.65 ±0.20)
		3mΩ~100mΩ			0.106 ±0.016 (2.70 ±0.40)	

**Product Dimensions (Cont.):**

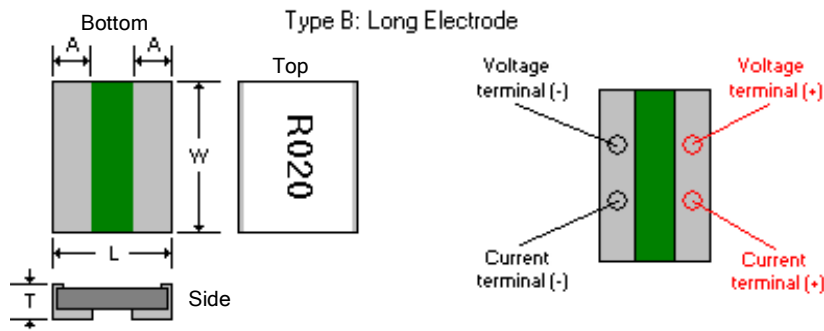

All dimensions in inches, mm in parentheses.

Dimension (Metric)	Electrode Type	Resistance Range	L	W	A	T
D1WEL0508 (1220)	B	1mΩ~100mΩ	0.053 ±0.008 (1.35 ±0.20)	0.083 ±0.008 (2.10 ±0.20)	0.026 ±0.008 (0.43 ±0.20)	0.017 ±0.008 (0.65 ±0.20)
D1WEL0612 (1632)	B	1mΩ	0.067 ±0.008 (1.70 ±0.20)	0.129 ±0.008 (3.30 ±0.20)	0.022 ±0.012 (0.55 ±0.30)	0.026 ±0.008 (0.65 ±0.20)
		2mΩ~4mΩ			0.016 ±0.008 (0.40 ±0.20)	
		5mΩ~100mΩ				
D1WEL0815 (2040)	B	1mΩ~100mΩ	0.087 ±0.008 (2.20 ±0.20)	0.150 ±0.008 (3.80 ±0.20)	0.024 ±0.008 (0.61 ±0.20)	0.026 ±0.008 (0.65 ±0.20)
D1WEL1020 (2550)	B	1mΩ~100mΩ	0.102 ±0.008 (2.60 ±0.20)	0.201 ±0.008 (5.10 ±0.20)	0.026 ±0.008 (0.65 ±0.20)	0.026 ±0.008 (0.65 ±0.20)
D1WEL1225 (3264)	B	1mΩ~100mΩ	0.126 ±0.012 (3.20 ±0.30)	0.252 ±0.012 (6.40 ±0.30)	0.024 ±0.008 (0.60 ±0.20)	0.026 ±0.008 (0.65 ±0.20)
D1WEL0830 (2276)	B	1mΩ~100mΩ	0.102 ±0.012 (2.60 ±0.30)	0.299 ±0.012 (7.60 ±0.30)	0.027 ±0.012 (0.68 ±0.30)	0.026 ±0.008 (0.65 ±0.20)
D1WEL1530 (3876)	B	1mΩ~100mΩ	0.153 ±0.012 (3.90 ±0.30)	0.303 ±0.012 (7.70 ±0.30)	0.027 ±0.012 (0.70 ±0.30)	0.026 ±0.008 (0.65 ±0.20)
D1WEL1836 (4590)	B	1mΩ~100mΩ	0.181 ±0.012 (4.60 ±0.30)	0.358 ±0.012 (9.10 ±0.30)	0.031 ±0.012 (0.80 ±0.30)	0.026 ±0.008 (0.65 ±0.20)
D1WEL2043 (05110)	B	1mΩ~100mΩ	0.201 ±0.012 (5.10 ±0.30)	0.437 ±0.016 (11.10 ±0.40)	0.035 ±0.012 (0.90 ±0.30)	0.026 ±0.008 (0.65 ±0.20)

**Electrical Specifications:**

Type	D1WEL0603		D1WEL0805		D1WEL1206		D1WEL2010		D1WEL2512		D1WEL4320		D1WEL4527	
Electrode Style	Type "A" - Short Side Electrode													
Metric Size	1608		2012		3216		5025		6432		11050		11470	
Power Rating	1/2W		3/4W		1W		1.5W		2W		3W		4W	
Resistance Range (mΩ)	5~9	10~100	3	4~500	3	4~700	2~9	10~700	2~3	4~700	2~9	10~100	2~9	10~100
Resistance Tolerance % (code)	±1.0(F)	±0.5(D) ±1.0(F)	±1.0(F)	±0.5(D) ±1.0(F)	±1.0(F)	±0.5(D) ±1.0(F)	±1.0(F)	±0.5(D) ±1.0(F)	±1.0(F)	±0.5(D) ±1.0(F)	±1.0(F)	±0.5(D) ±1.0(F)	±1.0(F)	±0.5(D) ±1.0(F)
TCR ppm/°C	±75	±50	±75	±50	±75	±50	±100	±50	±75	±50	±100	±50	±100	±50
Operating Temp. Range	-55°C~+155°C													
Rated Voltage	$\sqrt{\text{Power} \times \text{Resistance}}$													
Packaging (code)	5,000 pcs/reel (-T5)						4,000 pcs/reel (-T4)				2,000 pcs/reel (-T2)		1,000 pcs/reel (-T1)	

**Electrical Specifications (Cont.):**

Type	D1WEL0508		D1WEL0612		D1WEL0815		D1WEL1020		D1WEL1225	
Electrode Style	Type "B" - Long Side Electrode									
Metric Size	1220		1632		2040		2550		3264	
Power Rating	1W		1.5W		2W				3W	
Resistance Range (mΩ)	1~9	10~100	1~2, 4~9	3*, 10~100	1~9	10~100	1~9	10~100	1~9	10~100
Resistance Tolerance % (code)	±1.0(F)	±0.5(D) ±1.0(F)	±1.0(F)	±0.5(D) ±1.0(F)	±1.0(F)	±0.5(D) ±1.0(F)	±1.0(F)	±0.5(D) ±1.0(F)	±1.0(F)	±0.5(D) ±1.0(F)
TCR ppm/°C	±100	±50	±100	±50	±100	±50	±100	±50	±100	±50
Operating Temp. Range	-55°C~+155°C									
Rated Voltage	$\sqrt{\text{Power} \times \text{Resistance}}$									
Packaging (code)	5,000 pcs/reel (-T5)					4,000 pcs/reel (-T4)				

\* Note: 3mΩ~50mΩ in 0612 case size only available in 1.0% (F) tolerance

Type	D1WEL0830		D1WEL1530		D1WEL1836		D1WEL2043	
Electrode Style	Type "B" - Long Side Electrode							
Metric Size	2276		3876		4590		05110	
Power Rating	3W		4W				5W	
Resistance Range (mΩ)	1~9	10~100	1~9	10~100	1~9	10~100	1~9	10~100
Resistance Tolerance % (code)	±1.0(F)	±0.5(D) ±1.0(F)	±1.0(F)	±0.5(D) ±1.0(F)	±1.0(F)	±0.5(D) ±1.0(F)	±1.0(F)	±0.5(D) ±1.0(F)
TCR ppm/°C	±100	±50	±100	±50	±100	±50	±100	±50
Operating Temp. Range	-55°C~+155°C							
Rated Voltage	$\sqrt{\text{Power} \times \text{Resistance}}$							
Packaging (code)	4,000 pcs/reel (-T4)			2,000 pcs/reel (-T2)				

**Power Derating Curve:**

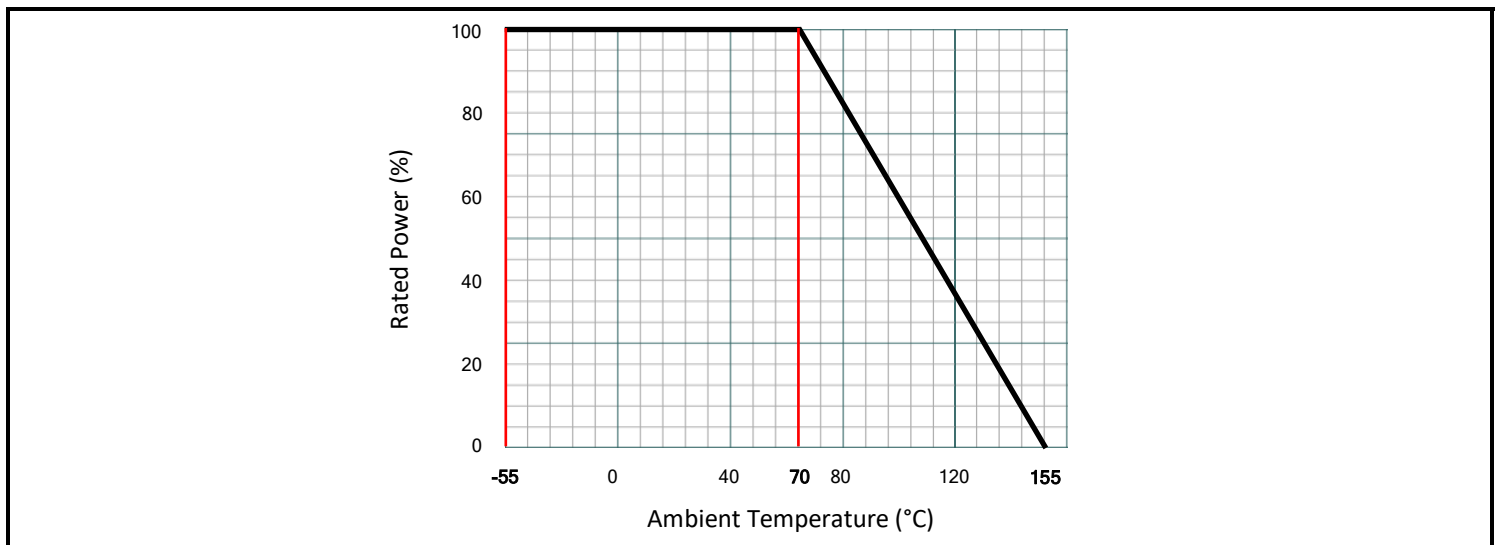

**Reliability Specifications:**

Test	Procedure	Specification
<b>Resistance Data</b>	Resistance data at 25°C	Must meet datasheet requirements
<b>TCR Data</b>	TCR data at 25°C and 125°C	Must meet datasheet requirements
<b>Dimensional Data</b>	Measure all dimensions specified in datasheet	Must meet datasheet requirements
<b>Short Time Overload</b> JIS-C-5201, 4.13	Applied voltage: 2.5X rated power. Test duration: 5 seconds	$\pm(1.0\%+0.5m\Omega)$
<b>Load Life (1)</b> JIS-C-5201-1, 4.25	Test Temperature: 70°C $\pm$ 2°C Applied voltage: rated voltage Test period: 1,000 hours with power cycling as follows: 90 min. power ON/30 min. power OFF,	$\pm(1.0\%+0.5m\Omega)$
<b>Moisture Load Life</b> JIS-C-5201-1, 4.24	Test Condition: 60°C $\pm$ 2°C, 95% RH 90 min. power ON/30 min. power OFF,	$\pm(1.0\%+0.5m\Omega)$
<b>Temperature Cycle (1)</b> (Thermal Shock) JESD22-A-104	Repeat 1,000 cycles as follows: -55 $\pm$ 3°C (30 min.) / +155 $\pm$ 3°C (30 min.) Transition time of 1 minute maximum	$\pm(1.0\%+0.5m\Omega)$
<b>Resistance To Solder Heat</b> IEC60115-1 4.18	Through reflow, parts are subjected to 3 reflow cycles	$\pm(1.0\%+0.5m\Omega)$
<b>High Temperature Exposure</b> MIL-STD-202, Method 108, Condition D	Test Temperature: Maximum rated operational temperature Test period: 1,000 hours No electrical load	$\pm(1.0\%+0.5m\Omega)$
<b>Low Temperature Exposure</b> IEC06115-1 4.25	T= -55°C $\pm$ 2°C; t= 1000h	$\pm(1.0\%+0.5m\Omega)$
<b>Mechanical Shock</b> MIL-STD-202, Method 213, Condition A	A= 100G, t= 6ms	$\pm(1.0\%+0.5m\Omega)$
<b>Solderability</b> MIL-STD-202, Method 208H, Category 3	Dipped into molten solder for 3 $\pm$ 1 seconds at 245 $\pm$ 5°C Flux activity type R0	New solder coverage of 90% minimum
<b>Substrate Bending</b> IEC60115-1 4.33	Span between fulcrums: 90mm Bend width: 2mm Test board: glass-epoxy Thickness: 1.6mm	$\pm(1.0\%+0.5m\Omega)$

**AEC-Q200 Test Requirements (Table 7):**

AEC Test #	Test Name	AEC-Q200 Test Requirements	Specification
3	High Temp. Exposure (Storage) MIL-STD-202, Method 108	Test Temp 125°C +/-3°C Test Period: 1,000 hours No Electrical Load	±1.0%
4	Temp. Cycling (Thermal Shock) JESD22 Method JA-104	Repeat 1,000 cycles as follows: -55° +/-3°C for 30 minutes +125°C +/-3°C for 30 minutes Transition time of 1 minute max	±1.0%
7	Biased Humidity MIL-STD-202, Method 103	Test conditions: 85°C and 85% RH 10% of rated power Test Period 1,000 hours	±1.0%
8	Load Life (Operational Life) MIL-STD-202, Method 108	Test Temperature: 125°C +/-3°C Applied voltage: rated power (derated Power will be required if temp exceeds the derating point of part) Test Period: 1,000 hours (condition D)	±1.0%
12	Resistance to Solvents MIL-STD-202, Method 215	3 minute soak 2-3 ounce force 10 strokes/repetition 3 repetitions	No damage
13	Mechanical Shock MIL-STD-202, Method 213	Force: 100G peak Test duration: 6 ms Half-sine waveform Velocity: 12.3ft/sec	±1.0%
14	Vibration MIL-STD-202, Method 204	Frequency: 10-2,000 Hz Acceleration: 5G Test duration: 20 minutes, 12 cycles	±1.0%
15	Resistance to soldering heat MIL-STD-202, Method 210	Condition B (Solder dip, no pre-heat) 260°C +/-5°C	±1.0%
17	ESD AEC-Q200-002	HBM, 100pF, 1.5k ohms Repetition: 5 times	±1.0%
18	Solderability J-STD-002	Non-activated flux dip: 5-10 seconds SAC solder dip: 2 +/-0.5 seconds at 245°C +/-5°C	95% coverage
20	Flammability UL-94	V-0 or V-1 are acceptable Electrical test not required	Provide certificate
21	Board Flex AEC-Q200-005	90 mm span between fulcrums 2 mm bend 60 seconds minimum holding time	±1.0%
22	Terminal Strength (SMD) AEC-Q200-006	Force of 17.7 N 60 seconds	±1.0%
24	Flame Retardance AEC-Q200-001	Mounted parts subjected to voltages from 9.0 to 32 VDC (current clamped up to 500A) in 1.0 VDC increments. Voltage applied for 1 hour minimum or until failure occurs	Must meet AEC-Q200 requirements

**Paper Tape Dimensions:**

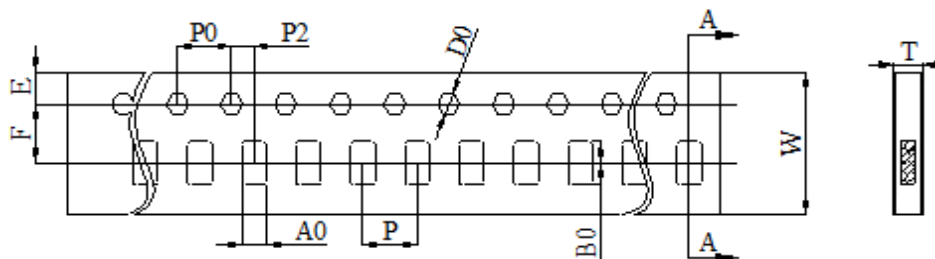

All dimensions in mm.

Size	W	P0	P	P2	A0	B0	D0	F	E	T
0603	8.00 ±0.30	4.00 ±0.10	4.00 ±0.10	2.00 ±0.10	1.10 ±0.10	1.90 ±0.10	1.50 ±0.10	3.50 ±0.10	1.75 ±0.10	0.75 ±0.10
0805	8.00 ±0.30	4.00 ±0.10	4.00 ±0.10	2.00 ±0.10	1.55 ±0.10	2.30 ±0.10	1.50 ±0.10	3.50 ±0.10	1.75 ±0.10	0.87 ±0.10
1206	8.00 ±0.30	4.00 ±0.10	4.00 ±0.10	2.00 ±0.10	2.05 ±0.20	3.65 ±0.20	1.50 ±0.10	3.50 ±0.10	1.75 ±0.10	0.87 ±0.10
0508	8.00 ±0.30	4.00 ±0.10	4.00 ±0.10	2.00 ±0.10	1.55 ±0.10	2.30 ±0.10	1.50 ±0.10	3.50 ±0.10	1.75 ±0.10	0.87 ±0.10
0612	8.00 ±0.30	4.00 ±0.10	4.00 ±0.10	2.00 ±0.10	2.05 ±0.20	3.65 ±0.20	1.50 ±0.10	3.50 ±0.10	1.75 ±0.10	0.87 ±0.10

**Plastic Tape Dimensions:**

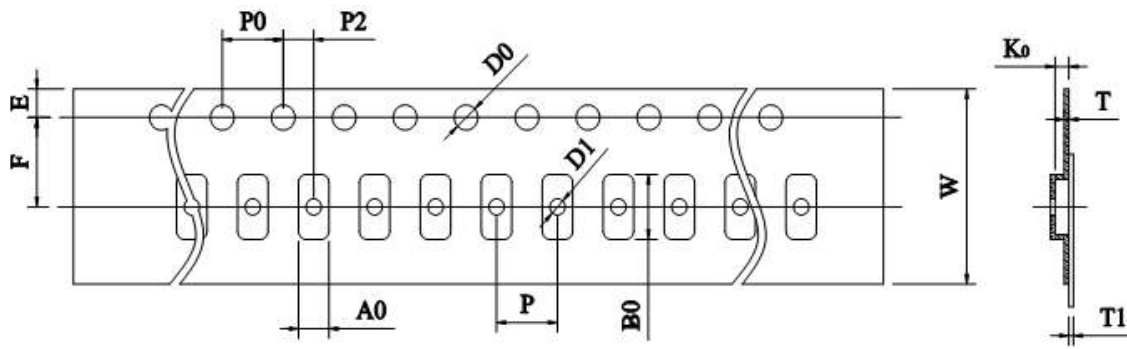

All dimensions in mm.

Size	W	P0	P	P2	A0	B0	D0	F	E	T	T1	K0					
2010	12.0 ±0.30	4.00 ±0.10	4.00 ±0.10	2.00 ±0.10	2.85 ±0.20	5.45 ±0.20	1.50 ±0.10	5.50 ±0.10	1.75 ±0.10	0.25 ±0.10	Max 0.10	0.80 ±0.20					
2512					3.40 ±0.20	6.75 ±0.20						1.00 ±0.20					
4320	24.0 ±0.30		8.00 ±0.10		5.50 ±0.20	11.5 ±0.20		0.30 ±0.10		0.90 ±0.20							
4527			12.0 ±0.10		7.50 ±0.20	12.0 ±0.20											
0815	12.0 ±0.40		4.00 ±0.10		4.00 ±0.10	2.00 ±0.10		2.30 ±0.20		4.10 ±0.20		1.50 ±0.10	5.50 ±0.10	1.75 ±0.10	0.25 ±0.10	Max 0.10	0.75 ±0.20
1020	12.0 ±0.30							2.85 ±0.20		5.45 ±0.20							0.80 ±0.20
1225	16.0 ±0.30		4.00 ±0.10		4.00 ±0.10	2.00 ±0.10		3.40 ±0.20		6.75 ±0.20		1.50 ±0.10	5.50 ±0.10	1.75 ±0.10	0.25 ±0.10	Max 0.10	1.00 ±0.20
0830								2.80 ±0.20		8.00 ±0.20							0.80 ±0.20
1530			8.00 ±0.10		4.00 ±0.10	4.00 ±0.10		2.00 ±0.10		4.15 ±0.20		7.95 ±0.20	1.50 ±0.10	7.50 ±0.10	1.75 ±0.10	0.25 ±0.10	Max 0.10
1836	4.85 ±0.20									9.35 ±0.20		0.90 ±0.20					
2043	24.0 ±0.30				8.00 ±0.10	8.00 ±0.10		2.00 ±0.10		5.50 ±0.20		11.5 ±0.20	1.50 ±0.10	11.5 ±0.10	1.75 ±0.10	0.30 ±0.10	Max 0.10

**Reel Dimensions:**

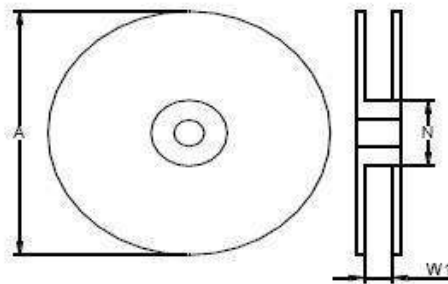

All dimensions in mm.

Size	0603	0805	1206	2010	2512	4320	4527	0508	0612	0815	1020	1225	0830	1530	1836	2043			
A	178 ±5.00																		
N	60.0 ±2.00																		
W1	9.00 ±1.00			13.0 ±1.00			24.5 ±1.00			9.00 ±1.00			13.0 ±1.00			17.0 ±1.00			24.5 ±1.00

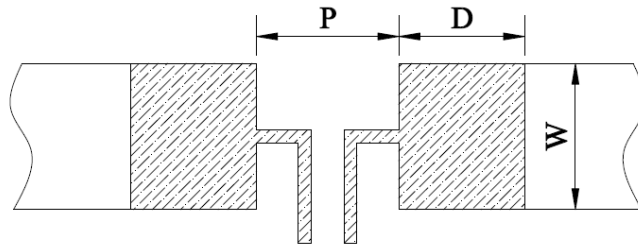
**Recommended Land Pattern:**

All dimensions in mm.

Size	Electrode Type	Resistance Range	P	W	D
0603	A	5mΩ	0.50	0.92	1.35
		6mΩ~100mΩ	0.60		1.30
0805	A	3mΩ	0.50	1.44	1.55
		4mΩ~500mΩ	0.80		1.40
1206	A	3mΩ	0.60	1.84	2.10
		4mΩ~700mΩ	1.20		1.80
2010	A	2mΩ~3mΩ	0.70	2.88	3.65
		4mΩ~700mΩ	2.70		2.65
2512	A	2mΩ	0.60	3.57	4.35
		3mΩ	0.90		4.20
		4mΩ~700mΩ	3.10		3.10
4320	A	2mΩ	1.10	5.75	6.45
		3mΩ	1.70		6.15
		4mΩ~100mΩ	5.00		4.50
4527	A	2mΩ	1.20	8.05	6.65
		3mΩ~100mΩ	5.20		4.65
0508	B	1mΩ~100mΩ	0.60	2.30	1.10
0612	B	1mΩ, 3mΩ	0.50	3.68	1.35
		2mΩ, 4mΩ~100mΩ	0.60		1.30
0815	B	1mΩ~100mΩ	0.70	4.26	1.45
1020	B	1mΩ~100mΩ	1.00	5.75	2.25
1225	B	1mΩ~100mΩ	1.40	7.25	2.35
0830	B	1mΩ~100mΩ	0.95	8.63	2.28
1530	B	1mΩ~100mΩ	1.70	8.74	2.55
1836	B	1mΩ~100mΩ	2.10	10.4	2.70
2043	B	1mΩ~100mΩ	2.40	12.7	2.80



**Soldering Profile:**

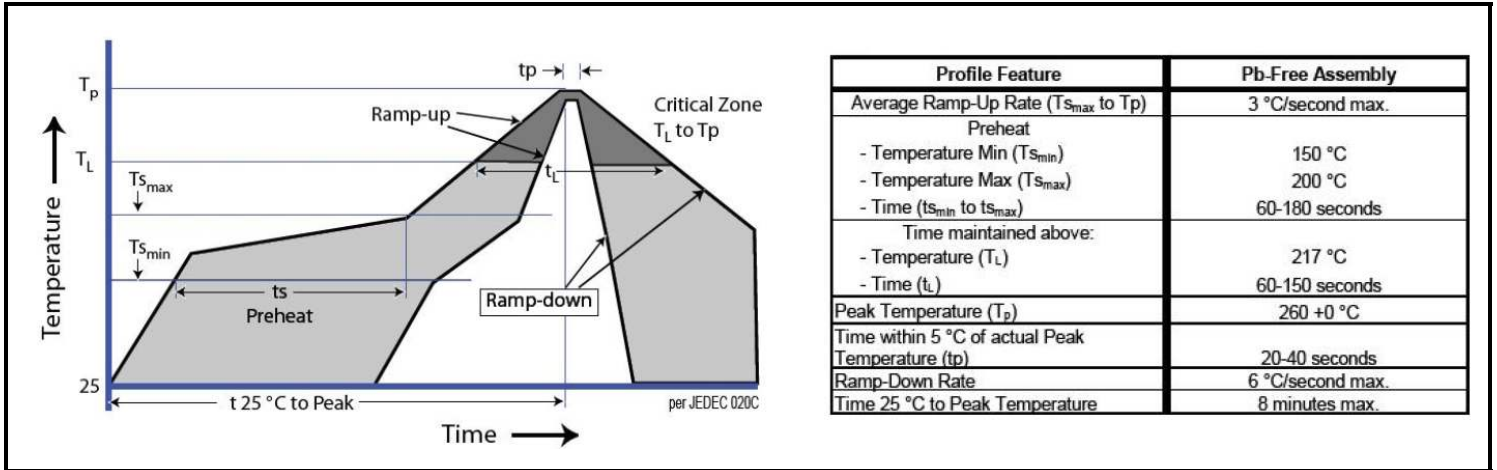

**Storage Conditions:**

**Environment Conditions:**  
 Products should be stored under the following environmental conditions.

- Temperature: +5 to +35°C
- Humidity: 45 to 85% relative humidity
- Do not keep products in environments where they may be subject to particulate contamination or harmful gases such as sulfuric acid or hydrogen chloride as it may cause oxidization on electrodes, resulting in poor solderability.
- Products should be stored in a space that does not expose it to high temperatures, vibration, or direct sunlight.
- Products should be stored in the original airtight packaging until use.