

Tous droits strictement réservés. Reproduction ou communication à des tiers interdite sous quelque forme que ce soit sans autorisation écrite du propriétaire. Propriété de c FCI. Droits de reproduction FCI.



All rights strictly reserved. Reproduction or issue to third parties in any form whatever is not permitted without written authority from the proprietor. Property of FCI. Copyright FCI.

1 | 2

3

4

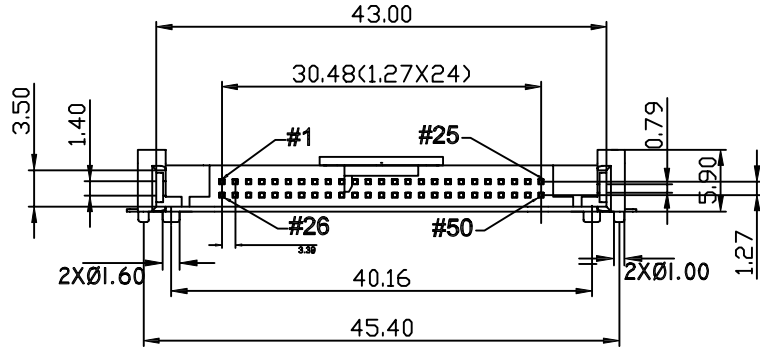
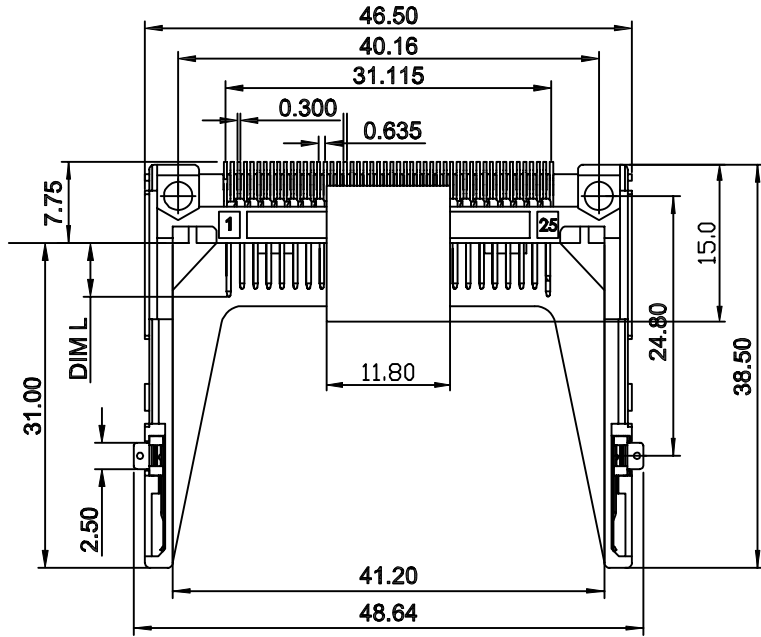

PIN NUMBER	DIM. L
25,26	3.50
ALL OTHER PINS	4.25
1, 13, 38, 50	5.00

NOTES :

- MATERIAL :  
INSULATOR : HIGH TEMPERATURE THERMOPLASTIC  
FLAMMABILITY RATING: UL94V-0  
COLOR: IVORY  
CONTACT : COPPER ALLOY  
GROUND MOUNTING EAR: COPPER ALLOY  
PICK-UP CAP: HIGH TEMP THERMOPLASTIC.
- PLATING :  
CONTACT AREA: SELECTIVE GOLD (SEE P/N DESCRIPTION)  
UNDER PLATING: 50u" NICKEL OVERALL  
SOLDER TAIL AREA: 100u" TIN/LEAD OR 100u" MATTE TIN  
GROUND MOUNT EAR AREA: 100u" TIN/LEAD OR 100u" MATTE TIN
- SOLDERTAILS TO BE WITHIN 0.05 UPWARD AND 0.2 DOWNWARD FROM Z-DATUM PLACE, AND COPLANARITY OF SOLDER TAILS TO BE WITHIN 0.10mm.
- PRODUCT SPEC: GS-12-240.
- PACKAGING SPEC: GS-14-980.

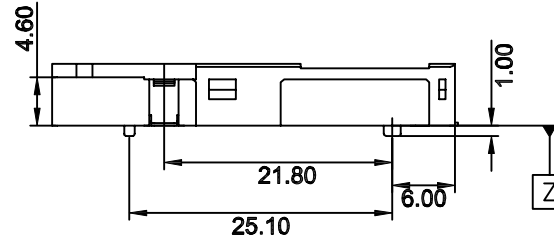

mat'l. code				tolerances unless otherwise specified				CUSTOMER COPY		FCI		
ltr	ecn no	dr	date	linear	.X ± 0.30		projection		www.fciconnect.com			
A	T05-0258	A.C.	11/21/05		.XX ± 0.20				title			
B	T06-0047	A.C.	3/07/06		.XXX ± 0.10				CF HEADER TYPE II NORMAL			
C	T08-1170	S.LIN	10/12/08	angles	0° ± 2°				S/O=0			
D	T09-1048	S.LIN	04/09/09	dr	ALLEN CHANG	2/22/05			MM	product family	CF	code
E	ELX-N-19494	HAN	11/17/14	enr	ALLEN CHANG	2/22/05					size	dwg no
				chr	STERLING LIN	2/22/05	scale	A4			10053867	sheet
				appd	H.C LIOU	2/22/05	NA			1 of 3		
sheet index	revision	E										
	sheet	1-3										

1 | 2

3

4

6. Part Number Description:

P/N: 10053867-XX50XX

- PLATING ON SOLDER TAIL AREA:  
BLANK: 100u" TIN/LEAD.  
LF: 100u" MATTE TIN.
- 0: WITH PICK-UP CAP + TAPE&REEL PACKAGE.  
1: WITHOUT PICK-UP CAP + TRAY PACKAGE.  
2: WITH PICK-UP CAP + TRAY PACKAGE.
- PIN COUNT.
- KEY TYPE:  
0: NORMAL TYPE
- GOLD PLATING:  
B: 10u" GOLD PLATE  
E: 30u" GOLD PLATE

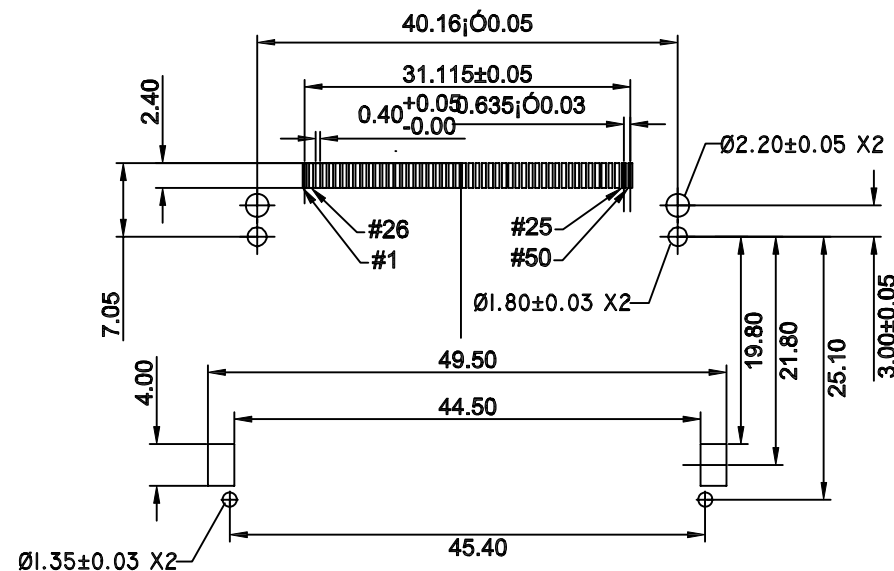

General Tolerance +/-0.05mm  
Recommended PCB Pattern

7. THIS PRODUCT (10053867-XXXXXLF) MEETS THE EUROPEAN UNION DIRECTIVE AS DESCRIBED IN GS-22-008.
8. THIS PRODUCT (10053867-XXXXX) MEETS THE EUROPEAN UNION DIRECTIVE AS DESCRIBED IN GS-22-008 EXCEPT FOR Pb.
9. THE HOUSING WILL WITHSTAND EXPOSURE TO 260°C PEAK TEMPERATURE FOR 10 SECONDS IN A CONVECTION, IR OR VAPOR PHASE REFLOW OVEN.
10. THE PRODUCTS WHERE THE PART NUMBER ENDS IN "LF" MEET THE CRITERIA SHOWN IN THE NOTES 7 AND 9.

Tous droits strictement reserves. Reproduction ou communication a des tiers interdite sous quelque forme que ce soit sans autorisation ecrite du proprietaire. Propriete de c FCI. Droits de reproduction FCI.



All rights strictly reserved. Reproduction or issue to third parties in any form whatever is not permitted without written authority from the proprietor. Property of FCI. Copyright FCI.

mat'l. code				tolerances unless otherwise specified				CUSTOMER COPY		 www.fciconnect.com			
ltr	ecn no	dr	date	linear	.X ± 0.30				projection	title			
E					.XX ± 0.20					CF HEADER TYPE II NORMAL			
					.XXX ± 0.10					S/O=0			
				angles	0° ± 2°				 MM	product family		code	
				dr	ALLEN CHANG	2/22/05	size			CF		TWN	
				enr	ALLEN CHANG	2/22/05	dwg no			10053867		sheet	
				chr	STERLING LIN	2/22/05	scale			A4		2 of 3	
				appd	H.C LIOU	2/22/05	NA						
sheet index	revision sheet	E											

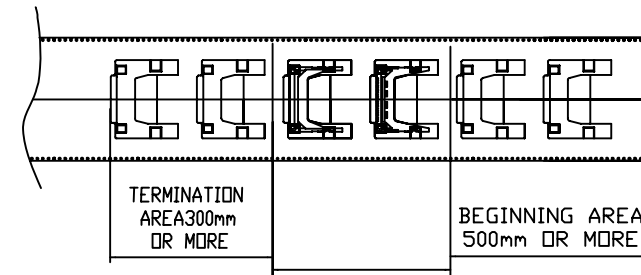
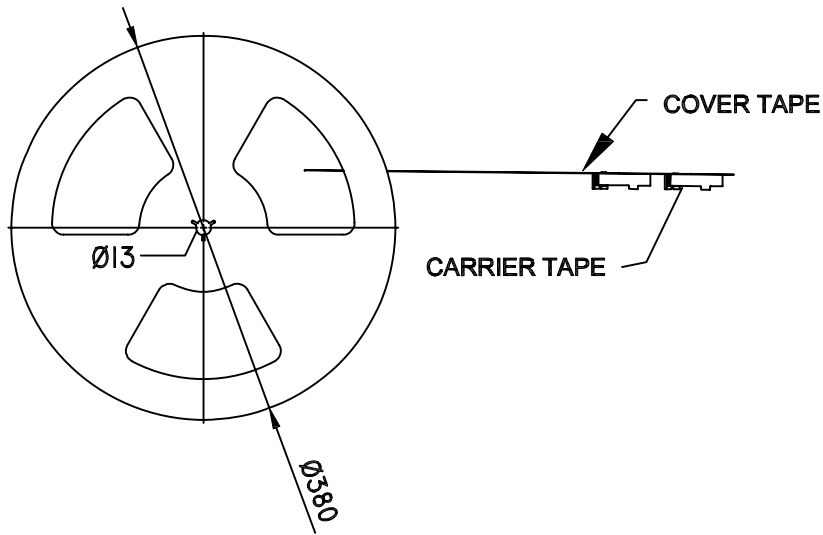
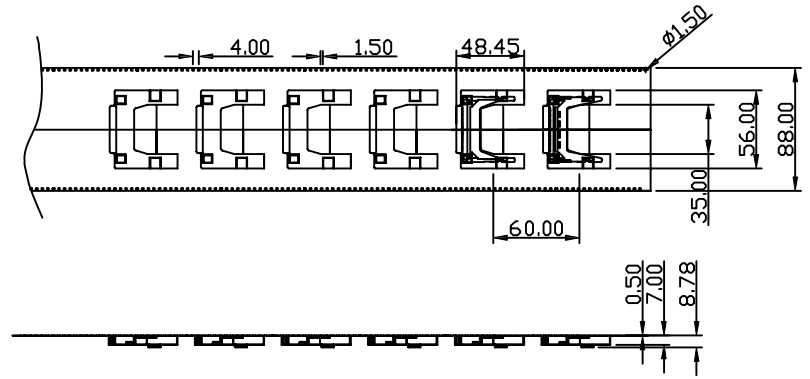
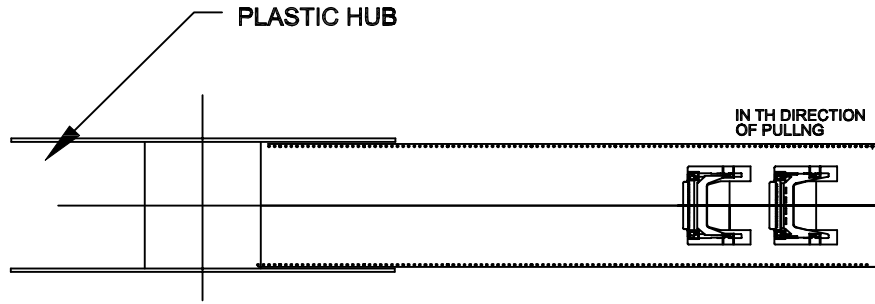

CONNECTOR PACKAGING  
AREA QUANTITY:150PCS

### COMPOSITION OF PACKAGING

- NOTES:**  
 1.CARRIER TAPE: PS T=0.4MM  
 2.COVER TAPE: PE  
 3.PLASTIC HUB: PS

mat'l. code				tolerances unless otherwise specified			CUSTOMER COPY		 www.fciconnect.com	
ltr	ecn no	dr	date	linear	.X ± 0.30		projection	title CF HEADER TYPE II NORMAL S/O=0		
E					.XX ± 0.20					
					.XXX ± 0.10					
				angles	0° ± 2°		 MM	product family CF		code
				dr	ALLEN CHANG	2/22/05		size dwg no		TWN
				enr	ALLEN CHANG	2/22/05	scale	A4		sheet
				chr	STERLING LIN	2/22/05		10053867		3 of 3
				appd	H.C LIOU	2/22/05				
sheet index	revision sheet	E								