

**ARM<sup>®</sup> Cortex<sup>®</sup>-M  
32-bit Microcontroller**

**NuMicro<sup>®</sup> Family  
NuTiny-SDK-Mini58  
User Manual**

*The information described in this document is the exclusive intellectual property of Nuvoton Technology Corporation and shall not be reproduced without permission from Nuvoton.*

*Nuvoton is providing this document only for reference purposes of NuMicro microcontroller based system design. Nuvoton assumes no responsibility for errors or omissions.*

*All data and specifications are subject to change without notice.*

For additional information or questions, please contact: Nuvoton Technology Corporation.

[www.nuvoton.com](http://www.nuvoton.com)

**Table of Contents**

1 OVERVIEW ..... 3

2 NUTINY-SDK-Mini58 INTRODUCTION ..... 4

    2.1 Virtual COM Port Switch Description ..... 4

    2.2 NuTiny-SDK-Mini58 Power Setting and Connector ..... 4

        2.2.1 Power Setting ..... 4

        2.2.2 Debug Connector ..... 5

        2.2.3 ICE USB Connector ..... 5

        2.2.4 Extended Connector ..... 5

        2.2.5 Reset Button ..... 5

        2.2.6 Power Connector ..... 5

        2.2.7 Virtual COM Port Function Switch ..... 5

    2.3 Pin Assignment for Extended Connector ..... 6

    2.4 NuTiny-SDK-Mini58 PCB Placement ..... 8

3 How to Start NuTiny -SDK-Mini58 on the Keil  $\mu$ Vision<sup>®</sup> IDE ..... 9

    3.1 Downloading and Installing Keil  $\mu$ Vision<sup>®</sup> IDE Software ..... 9

    3.2 Downloading and Installing Nuvoton Nu-Link Driver ..... 9

    3.3 Hardware Setup ..... 9

    3.4 Example Program ..... 9

4 How to Start NuTiny -SDK-Mini58 on the IAR Embedded Workbench ..... 13

    4.1 Downloading and Installing IAR Embedded Workbench Software ..... 13

    4.2 Downloading and Installing Nuvoton Nu-Link Driver ..... 13

    4.3 Hardware Setup ..... 13

    4.4 Example Program ..... 13

5 NuTiny-EVB-Mini58 Schematic ..... 17

    5.1 Nu-Link-Me Schematic ..... 17

    5.2 SDK Circuit Schematic ..... 18

    5.3 NuTiny-SDK-MINI58 Schematic ..... 19

    5.4 GPIO for 48 pin Schematic ..... 20

6 Downloading NuMicro<sup>®</sup> Related Files from Nuvoton Website ..... 21

    6.1 Downloading NuMicro<sup>®</sup> Keil  $\mu$ Vision<sup>®</sup> IDE Driver ..... 21

    6.2 Downloading NuMicro<sup>®</sup> IAR EWARM Driver ..... 23

    6.3 Downloading NuMicro<sup>®</sup> Mini58 Series BSP Software Library ..... 25

7 REVISION HISTORY ..... 27

## 1 OVERVIEW

NuTiny-SDK-Mini58 is the specific development tool for NuMicro<sup>®</sup> Mini58 series. User can use NuTiny-SDK-Mini58 to develop and verify the application program easily.

NuTiny-SDK-Mini58 includes two portions. One is NuTiny-EVB-Mini58 and the other is Nu-Link-Me. NuTiny-EVB-Mini58 is the evaluation board and Nu-Link-Me is its Debug Adaptor. Thus, user does not need other additional ICE or debug equipment.

The NuMicro<sup>®</sup> Mini58 series is pin-to-pin and function compatible with the NuMicro<sup>®</sup> Mini51 series, the 32-bit microcontroller (MCU) embedded with the ARM<sup>®</sup> Cortex<sup>®</sup>-M0 core. The Mini58 series can bridge the gap and replace the cost equivalent to traditional 8- and 16-bit microcontroller by 32-bit performance and rich functions. The Mini58 series supports a wide range of applications from low-end, price sensitive designs to computing-intensive ones and provides advanced high-end features in economical products.

The Mini58 series can run up to 50 MHz which is faster than 24 MHz in Mini51 series, and operate at a wide voltage range of 2.5V ~ 5.5V and temperature range of -40°C ~ +105°C. For the Mini58 series, the embedded program flash size upgrades from 16 Kbytes to 32 Kbytes and SRAM upgrades from 2 Kbytes to 4 Kbytes. The Mini58 series also offers size configurable Data Flash (shared with program flash), and 2 Kbytes flash for the ISP.

The Mini58 series has many high-performance peripheral functions, such as 22.1184 MHz internal RC oscillator ( $\pm 1\%$  accuracy), I/O port with up to 30 pins, four 32-bit timers, two UARTs with the RS485 function and IrDA function interface, one SPI interface, two I<sup>2</sup>C interfaces, up to three 16-bit PWM generators providing six channels, an 8-channel 10-bit ADC, Watchdog Timer, Window Watchdog Timer, two Analog Comparators and a Brown-out Detector. All these peripherals have been incorporated into the Mini58 series to reduce component count, board space and system cost. Compared to the Mini51 series, the Mini58 series supports additional one UART and one I<sup>2</sup>C interface for better and more flexible connectivity applications.

Additionally, the Mini58 series is equipped with ISP (In-System Programming) and ICP (In-Circuit Programming) functions, which allow the user to update the program memory without removing the chip from the actual end product. The Mini58 series also supports In-Application-Programming (IAP) function, user switches the code executing without the chip reset after the embedded flash updated.

## 2 NUTINY-SDK-MINI58 INTRODUCTION

NuTiny-SDK-Mini58 uses the Mini58LDE as the target microcontroller. Figure 2-1 is NuTiny-SDK-Mini58 for the Mini58 series, the left portion is called NuTiny-EVB-Mini58 and the right portion is Debug Adaptor called Nu-Link-Me.

NuTiny-EVB-Mini58 is similar to other development boards. User can use it to develop and verify applications to emulate the real behavior. The on-board chip covers Mini58 series features. The NuTiny-EVB-Mini58 can be a real system controller to design user's target systems.

Nu-Link-Me is a Debug Adaptor. The Nu-Link-Me Debug Adaptor connects your PC's USB port to the user's target system (via Serial Wired Debug Port) and allows user to program and debug embedded programs on the target hardware. To use Nu-Link-Me Debug adaptor with IAR or Keil, please refer to "Nuvoton NuMicro® IAR ICE driver user manual" or "Nuvoton NuMicro® Keil ICE driver user manual" in detail. These two documents will be stored in the local hard disk when user installs each driver. Nu-Link-Me also supports virtual COM port function. User can use Nu-Link-Me as a USB to UART virtual COM port, which connects to on-board Mini58LDE UART0.

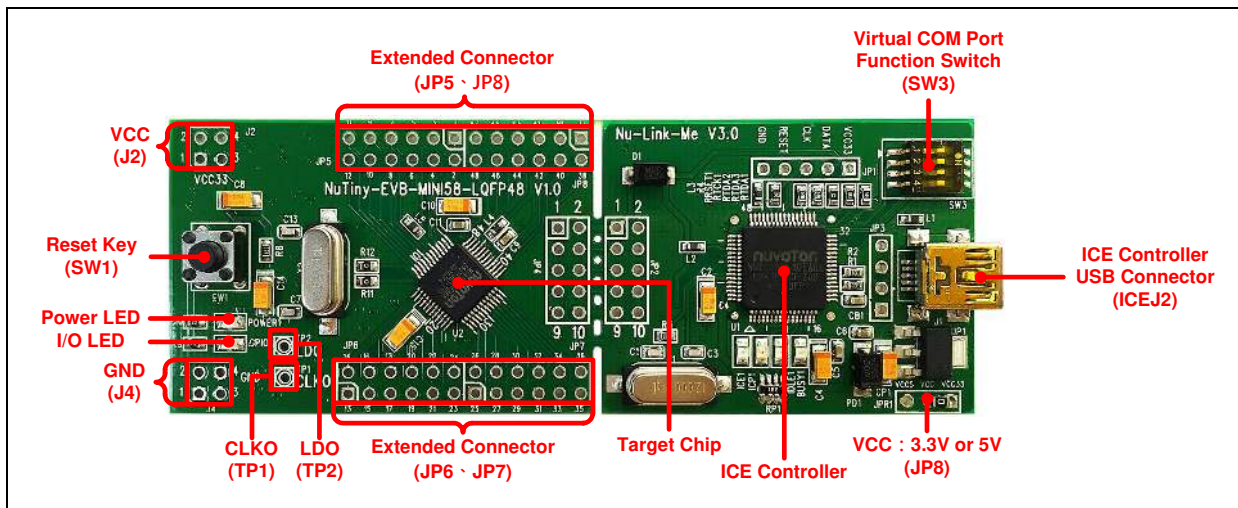

Figure 2-1 NuTiny-SDK-Mini58 (PCB Board)

### 2.1 Virtual COM Port Switch Description

The switch in Nu-Link-Me, SW3, determines that the virtual COM port function is enabled or disabled. When user turns on all of the positions of switch, the virtual COM port function will be enabled. By using virtual COM port function, user can access the USB device in the same way as it would access a standard COM port to Mini58LDE UART0. To use this function, user needs to install "VCOM Driver" at first. User can get "VCOM Driver" from NuMicroDVD in folder "Software Utilities".

### 2.2 NuTiny-SDK-Mini58 Power Setting and Connector

#### 2.2.1 Power Setting

- J1: USB port in Nu-Link-Me
- J2: VCC33 Voltage connector in NuTiny-EVB-Mini58

Model	JPR1	J1USB port	J2 VCC33	MCU Voltage
Model 1	Select VCC33 (default)	Connect to PC	DC 3.3V output	DC 3.3V

Model 2	X	X	DC 2.5 V ~ 5.5 V Input	Voltage by J2 input
---------	---	---	------------------------	---------------------

**2.2.2 Debug Connector**

- JP4: Connector in target board (NuTiny-EVB-Mini58) for connecting with Nuvoton ICE adaptor (Nu-Link-Me)
- JP2: Connector in ICE adaptor (Nu-Link-Me) for connecting with a target board (for example NuTiny-EVB-Mini58)

**2.2.3 ICE USB Connector**

- J2: Mini USB Connector in Nu-Link-Me connected to a PC USB port

**2.2.4 Extended Connector**

- JP5, JP6, JP7 and JP8: Show all chip pins in NuTiny-EVB-Mini58
- TP1: Show CLKO pin in Mini58LDE
- TP2: Show LDO pin in Mini58LDE

**2.2.5 Reset Button**

- SW1: Reset button in NuTiny-EVB-Mini58

**2.2.6 Power Connector**

- J2: 3.3 VCC connector in NuTiny-EVB-Mini58
- J4: GND connector in NuTiny-EVB-Mini58

**2.2.7 Virtual COM Port Function Switch**

- SW3: Switch ON/OFF to enable or disable Nu-Link-Me virtual COM port function.

Function	Switch				Descriptions
	1	2	3	4	
Enable	ON	ON	ON	ON	Enable Nu-Link-Me virtual COM port function
Disable	OFF	OFF	OFF	OFF	Disable Nu-Link-Me virtual COM port function

### 2.3 Pin Assignment for Extended Connector

NuTiny-EVB-Mini58 provides Mini58LDE on board and the extended connector for LQFP-48 pin. Table 2-1 is the pin assignment for Mini58LDE.

Pin No	Pin Function	Pin No	Pin Function
01	NC	25	P2.5,PWM0_CH3,UART1_TXD
02	P1.5,ADC_CH5,ACMP0_P0,UART1_TXD	26	P2.6,PWM0_CH4,ACMP1_O
03	nRESET	27	NC
04	P3.0,ADC_CH6,ACMP1_N	28	NC
05	AV <sub>SS</sub>	29	P4.6,ICE_CLK,UART1_RXD
06	P5.4	30	P4.7,ICE_DAT,UART1_TXD
07	P3.1,ADC_CH7,ACMP1_P0	31	NC
08	P3.2,INT0,STADC,TM0_EXT,ACMP1_P1	32	P0.7,SPI0_CLK,PWM0_CH0
09	P3.4,TM0_CNT_OUT,I2C0_SDA,ACMP1_P2	33	P0.6,SPI0_MISO,PWM0_CH1
10	P3.5,TM1_CNT_OUT,I2C0_SCL,ACMP1_P3	34	P0.5,SPI0_MOSI,PWM0_CH4
11	NC	35	P0.4,SPI0_SS,PWM0_CH5
12	NC	36	NC
13	NC	37	P0.1,UART0_nRTS,UART0_RXD,SPI0_SS
14	P3.6,CLKO,TM1_EXT,ACMP0_O	38	P0.0,UART0_nCTS,UART0_TXD
15	P5.1,XT1_OUT,I2C1_SCL,UART0_RXD	39	NC
16	P5.0,XT1_IN,I2C1_SDA,UART0_TXD	40	NC
17	V <sub>SS</sub>	41	P5.3,ADC_CH0
18	LDO_CAP	42	V <sub>DD</sub>
19	P5.5	43	AV <sub>DD</sub>
20	P5.2,INT1	44	P1.0,ADC_CH1,ACMP0_P1
21	NC	45	P1.2,ADC_CH2,UART0_RXD,

			ACMP0_P2,PWM0_CH0
22	P2.2,PWM0_CH0,I2C1_SCL	46	P1.3,ADC_CH3,UART0_TXD,ACMP0_P3, PWM0_CH1
23	P2.3,PWM0_CH1,I2C1_SDA	47	P1.4,ADC_CH4,ACMP0_N,UART1_RXD, PWM0_CH4
24	P2.4,PWM0_CH2,UART1_RXD	48	NC

Table 2-1 Pin Assignment for Mini58LDE

## 2.4 NuTiny-SDK-Mini58 PCB Placement

User can refer to Figure 2-2 for the NuTiny-SDK-Mini58 PCB placements.

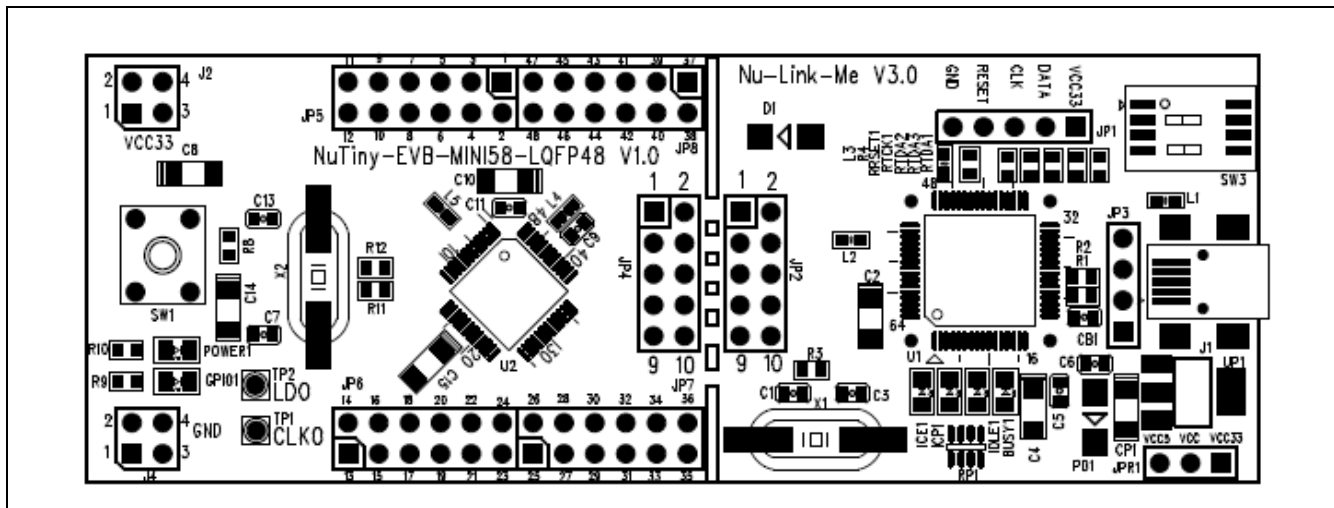

Figure 2-2 NuTiny-SDK-Mini58 PCB Placement



### 3 HOW TO START NUTINY -SDK-MINI58 ON THE KEIL MVISION® IDE

#### 3.1 Downloading and Installing Keil μVision® IDE Software

Please connect to the Keil company website (<http://www.keil.com>) to download the Keil μVision® IDE and install the RVMDK.

#### 3.2 Downloading and Installing Nuvoton Nu-Link Driver

Please connect to Nuvoton NuMicro® website (<http://www.nuvoton.com/NuMicro>) to download the “NuMicro® Keil μVision® IDE driver” file. Please refer to section 6.1 for the detailed download flow. After the Nu-Link driver is downloaded, please unzip the file and execute the “Nu-Link\_Keil\_Driver.exe” to install the driver.

#### 3.3 Hardware Setup

The hardware setup is shown as Figure 3-1



Figure 3-1 NuTiny-SDK-Mini58 Hardware Setup

#### 3.4 Example Program

This example demonstrates the ease of downloading and debugging an application on a NuTiny-SDK-Mini58 board. It can be found on Figure 3-2 list directory and downloaded from Nuvoton NuMicro® website.

The example file can be found in the directory list shown in Figure 3-2.

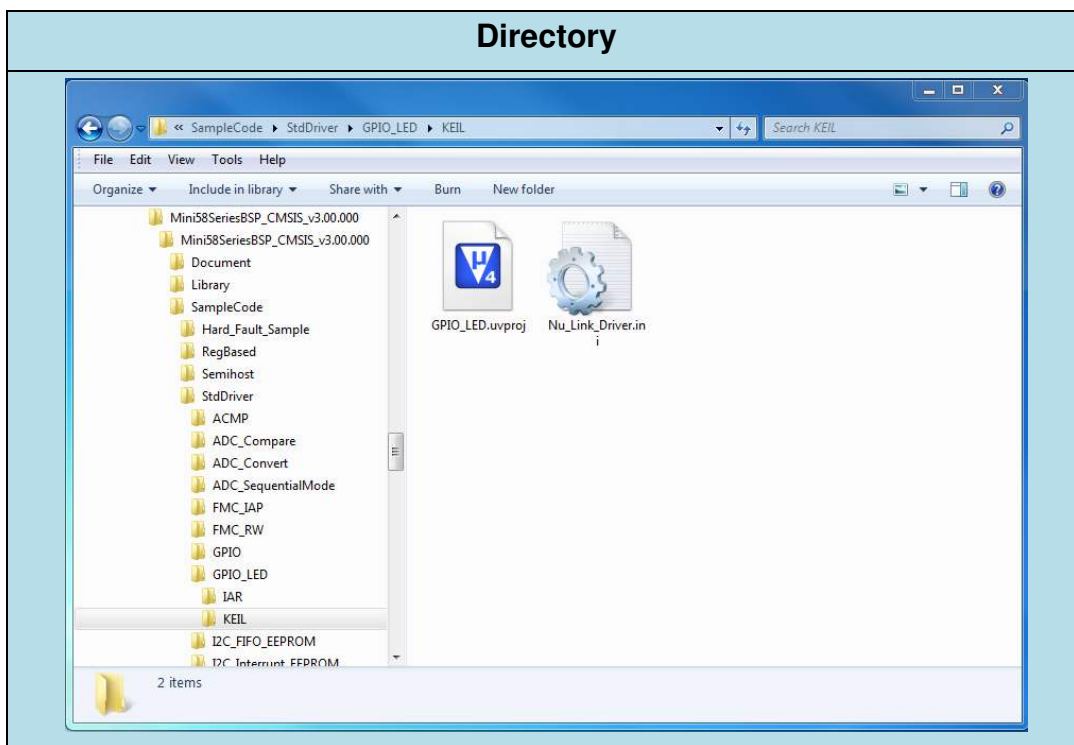
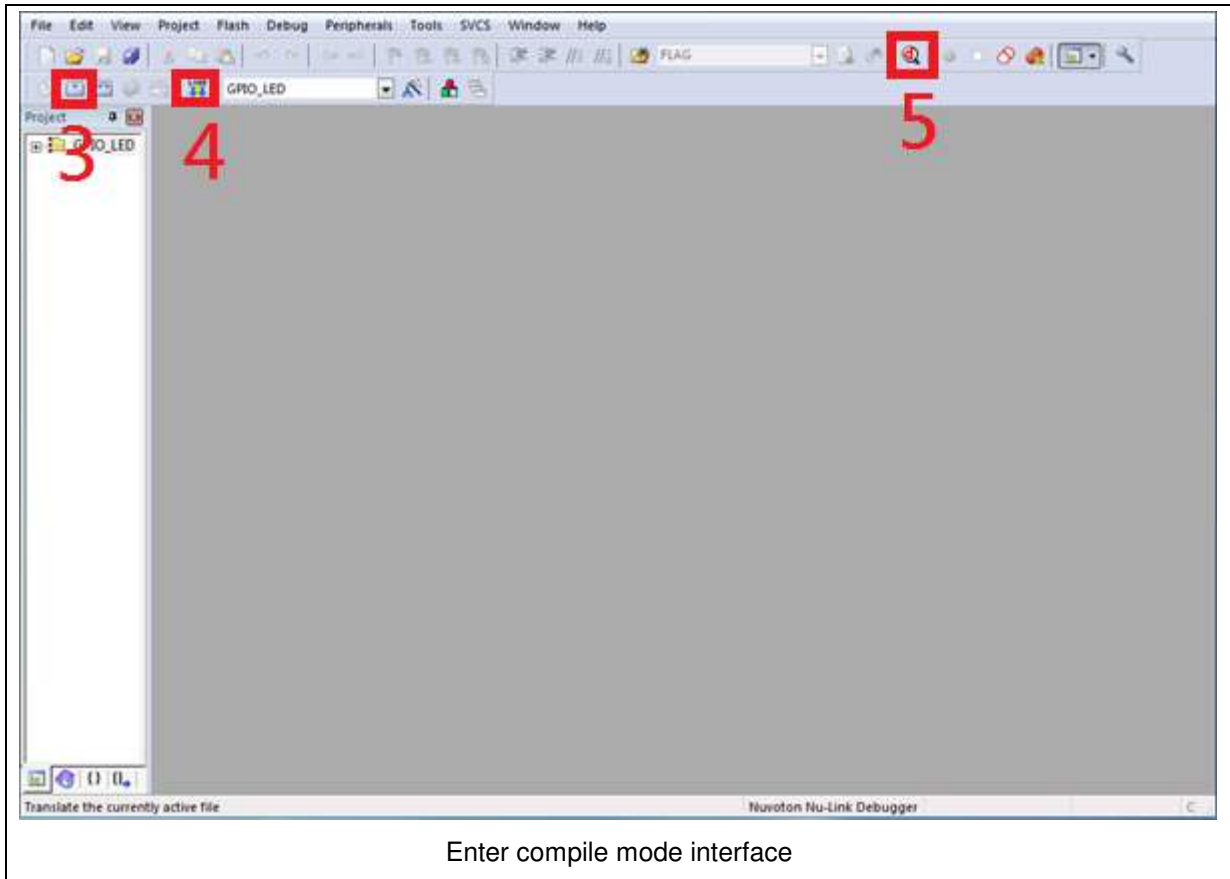





Figure 3-2 Example Directory

To use this example:

1. Open a project from the BSP installation folder (default as C:\Nuvoton) using the following path :  
 \Mini58SeriesBSP\_CMSIS\_v3.00.000\SampleCode\StdDriver\GPIO\_LED\KEIL
2. Execute “**GPIO\_LED.uvproj**”



3.  Compiler
4.  Download the program code to Flash
5.  Enter / Exit Debug mode

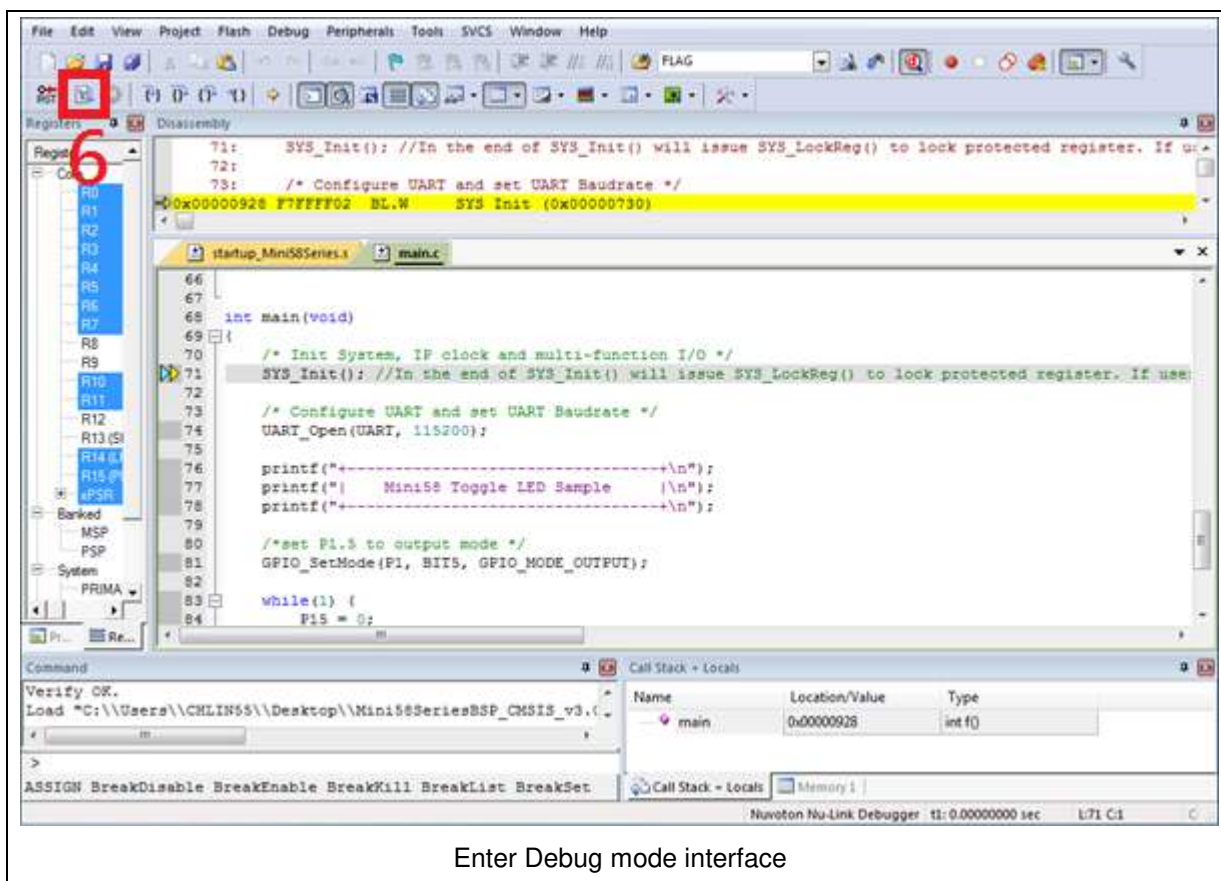

Enter Debug mode interface

6.  Execute the program
7. The I/O LED on the NuTiny-EVB-Mini58 board will be toggled on.

## 4 HOW TO START NUTINY -SDK-MINI58 ON THE IAR EMBEDDED WORKBENCH

### 4.1 Downloading and Installing IAR Embedded Workbench Software

Please connect to IAR company website (<http://www.iar.com>) to download the IAR Embedded Workbench and install the EWARM.

### 4.2 Downloading and Installing Nuvoton Nu-Link Driver

Please connect to Nuvoton NuMicro® website (<http://www.nuvoton.com/NuMicro>) to download the “NuMicro® IAR EWARM Driver” file. Please refer to section 6.2 for the detailed download flow. After the Nu-Link driver is downloaded, please unzip the file and execute the “Nu-Link\_IAR\_Driver.exe” to install the driver.

### 4.3 Hardware Setup

The hardware setup is shown as Figure 4-1.



Figure 4-1 NuTiny-SDK-Mini58 Hardware Setup

### 4.4 Example Program

This example demonstrates the ease of downloading and debugging an application on a NuTiny-SDK-Mini58 board. It can be found on Figure 4-2 list directory and downloaded from Nuvoton NuMicro® website.

The example file can be found in the directory list shown in Figure 4-2.

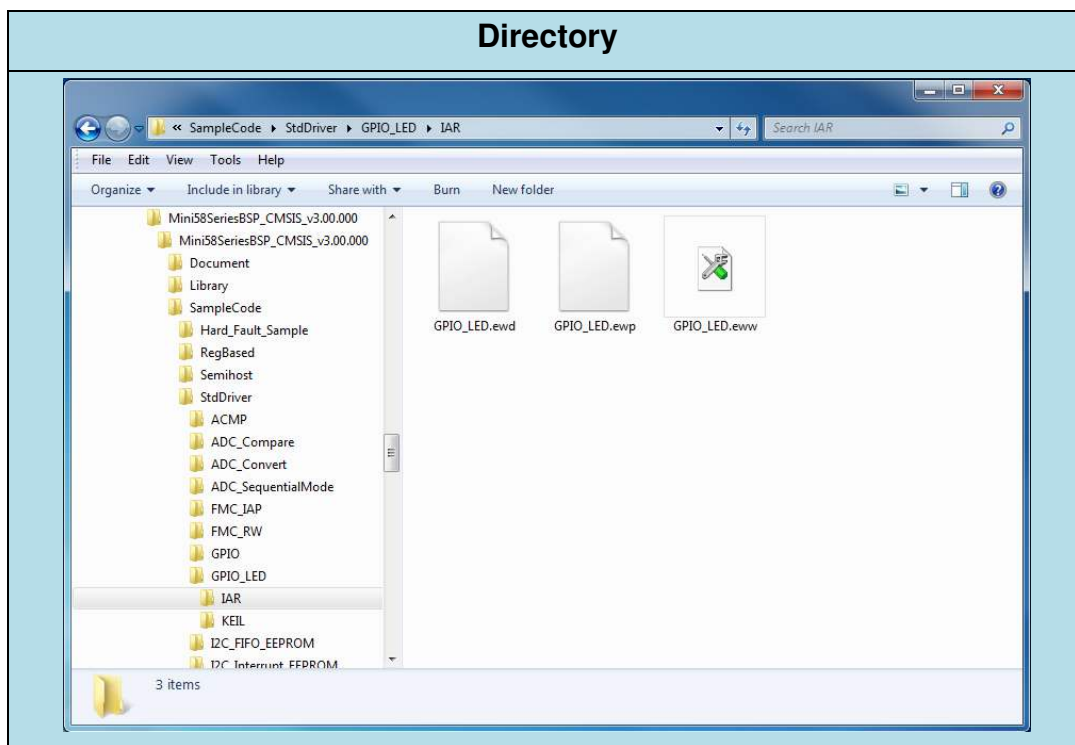
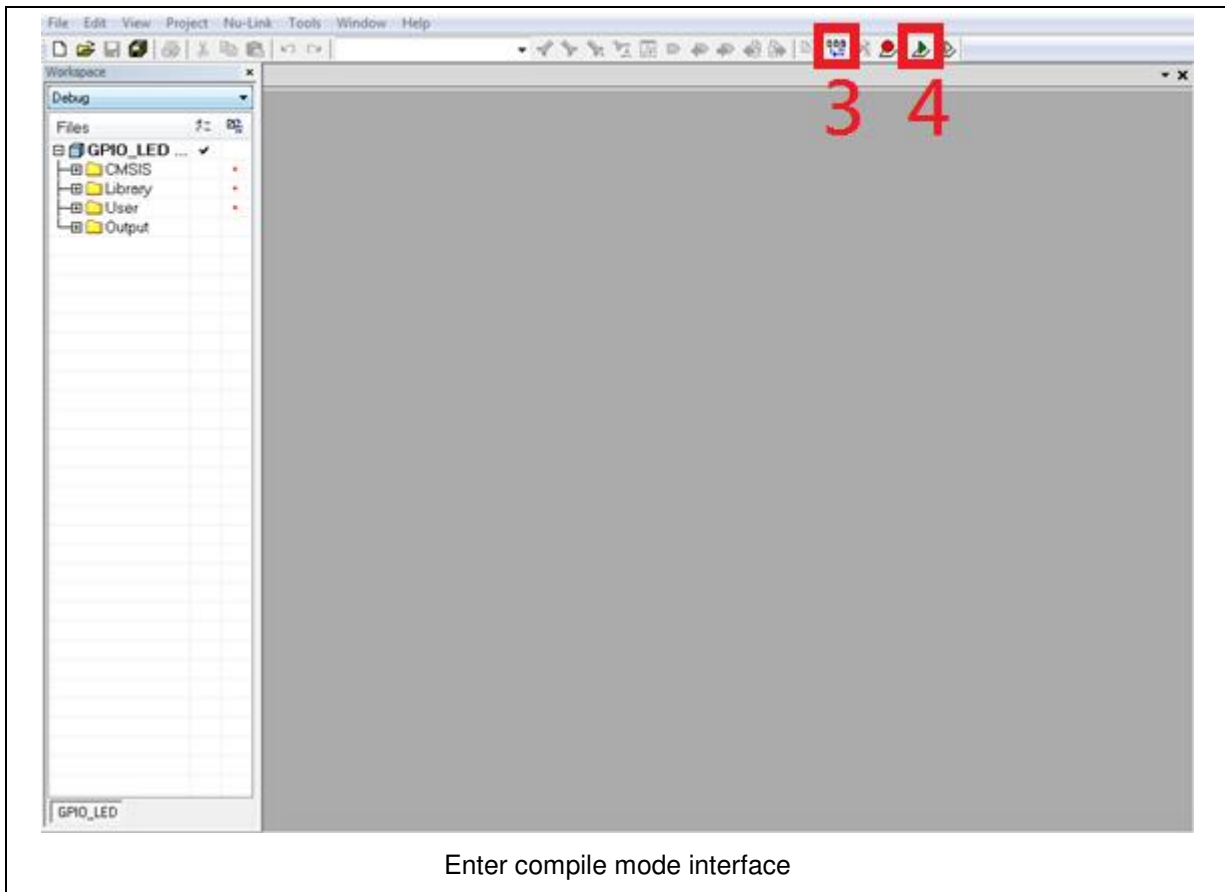



Figure 4-2 Example Directory

To use this example:

1. Open a project from the BSP installation folder (default as C:\Nuvoton) using the following path :  
 \Mini58SeriesBSP\_CMSIS\_v3.00.000\SampleCode\StdDriver\GPIO\_LED\IAR
2. Execute “**GPIO\_LED.eww**”



3.  Compile and make
4.  Download the program code to Flash and Enter Debug mode

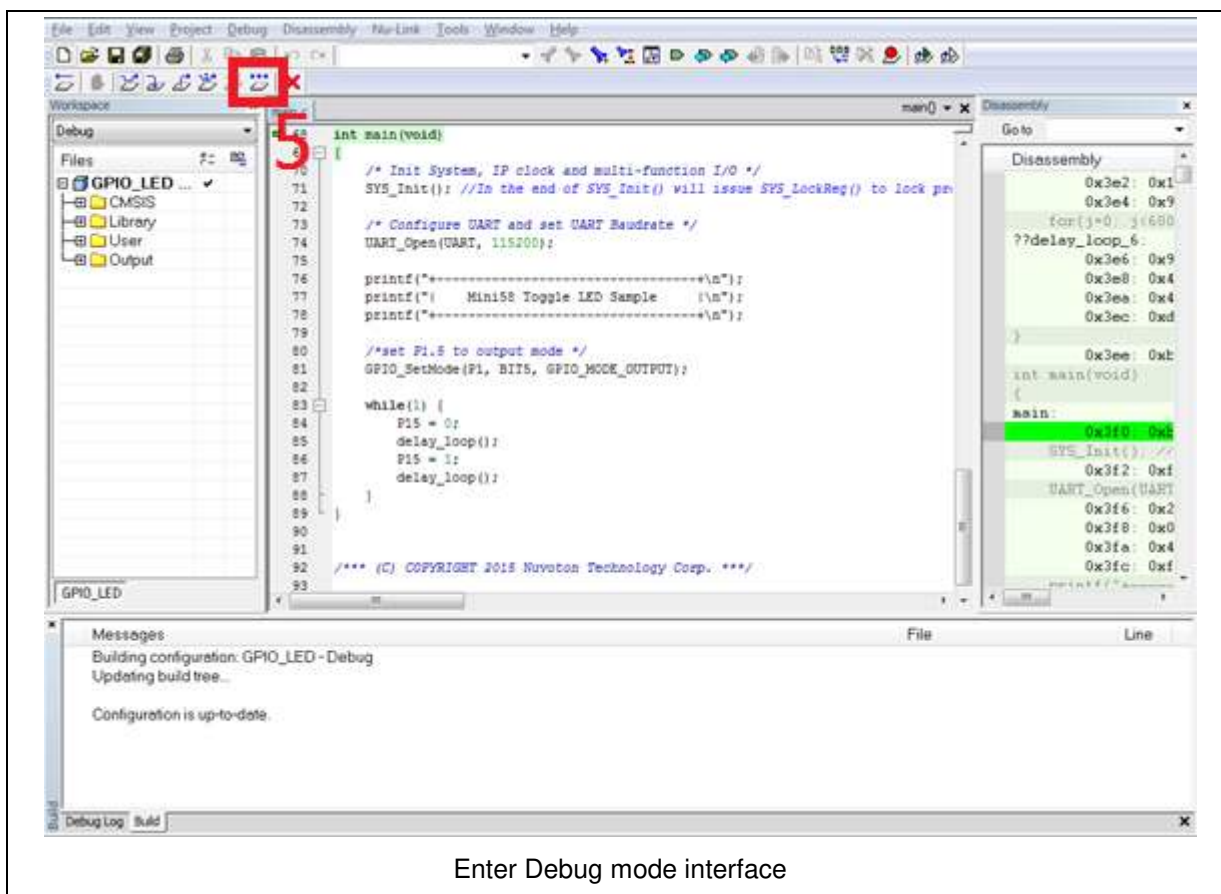

5.  Execute the program
6. The I/O LED on the NuTiny-EVB-Mini58 board will be toggled on.



## 5 NUTINY-EVB-MINI58 SCHEMATIC

### 5.1 Nu-Link-Me Schematic

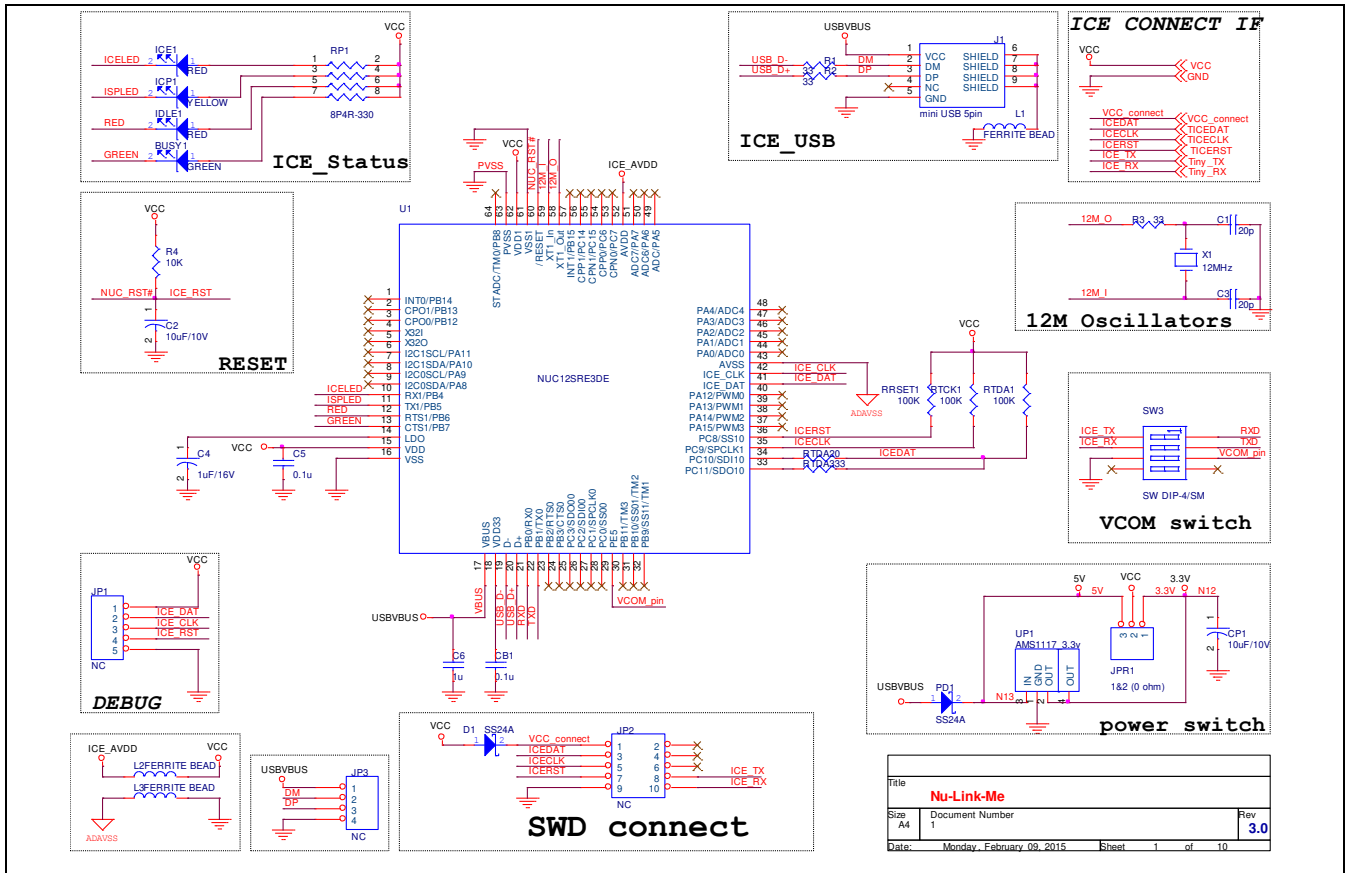

5.2 SDK Circuit Schematic

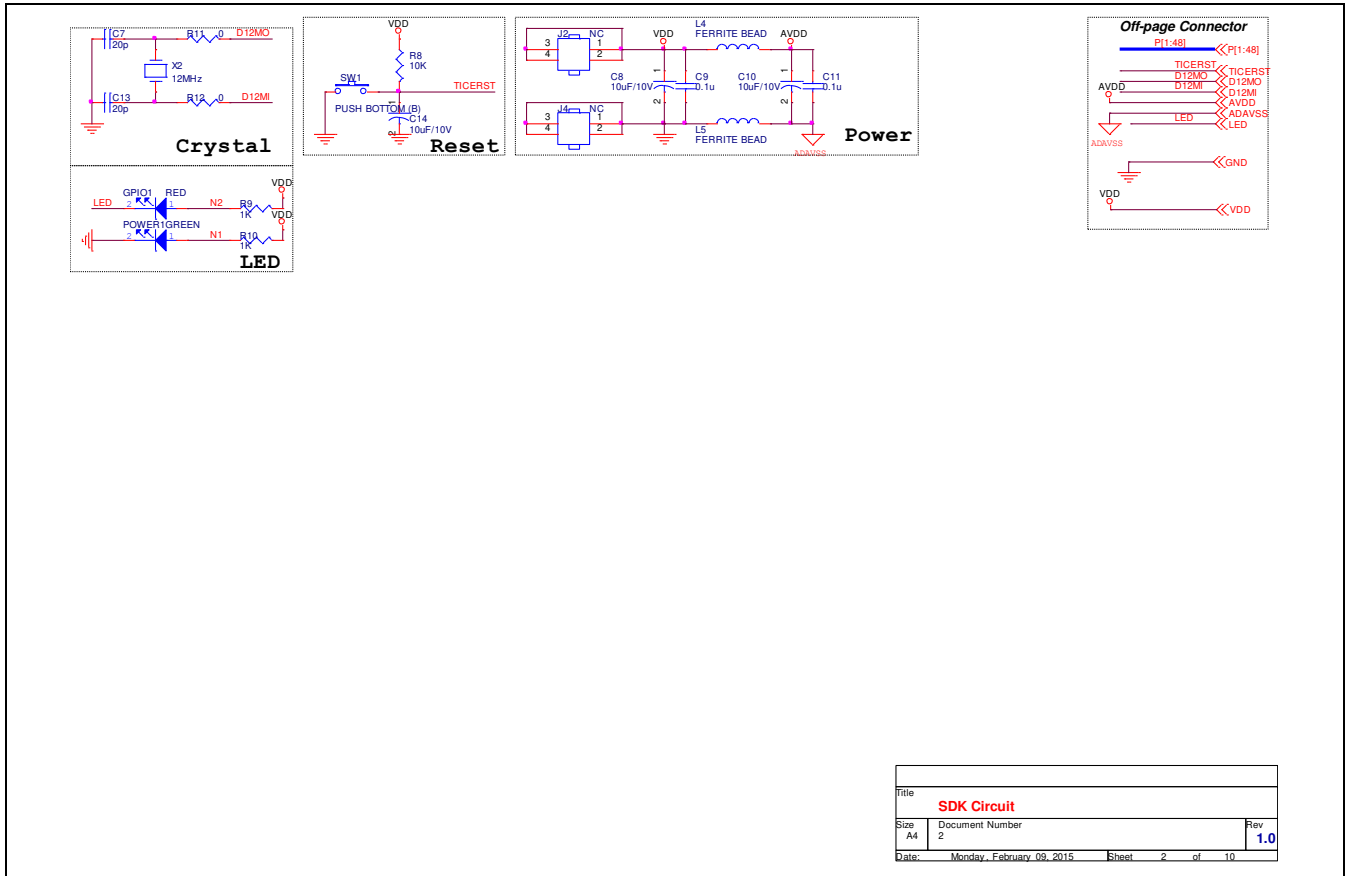

Title			Rev
SDK Circuit			1.0
Size	Document Number		
A4	2		
Date:	Monday, February 09, 2015	Sheet	2 of 10



5.4 GPIO for 48 pin Schematic

**Off-page Connector**  
 P[1:48] <<P[1:48]

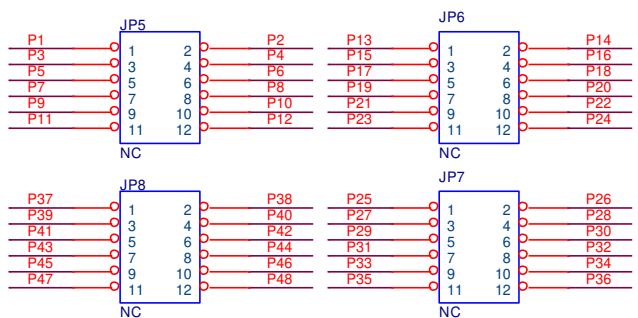

Title		<b>GPIO for 48 pin</b>	
Size	Document Number	Rev	
A4	<Doc>	1.0	
Date:	Monday, February 09, 2015	Sheet	4 of 10

NUTINY-SDK-MINI58 USER MANUAL

## 6 DOWNLOADING NUMICRO<sup>®</sup> RELATED FILES FROM NUVOTON WEBSITE

### 6.1 Downloading NuMicro<sup>®</sup> Keil $\mu$ Vision<sup>®</sup> IDE Driver

**Step1** Visit the Nuvoton NuMicro<sup>®</sup> website: <http://www.nuvoton.com/NuMicro>.

**Step2**

The screenshot shows the Nuvoton NuMicro website interface. A yellow oval labeled "2-1. Move to 'Support'" points to the "Support" link in the top navigation bar. A second yellow oval labeled "2-2. Click here to enter Tool & Software" points to the "Tool & Software" option in the dropdown menu that appears under "Support". The main content area features a product matrix with various microcontroller models (e.g., NUC100, Nano120, NUC220, NUC240, NUC230, NUC140, NUC130, M051, Nano102, Nano112, Mini51) plotted against memory size (16K, 32K, 64K) and application categories (Industrial Control, Low Power, USB Application, Automotive Application, Audio Application). A "Developing" label is present for the Mini51 model. The right sidebar includes sections for "Online Support" (Training, Forum, FAQ), "Featured Products" (M0516LDE, MINI54FDE, NANO130KE3BN), "Featured Videos" (M0 Introduction), and "Featured Applications".

Register | Login
Language

News | Events | CSR | Human Resources | Investors | Contact Us | Nuvoton Partner

Products
Applications
Support
Foundry Service
Buy
myNuvoton
About Nuvoton

Home > Support > Tool & Software

**Development Tool Hardware**

- Learning
- Product Related Information
- Tool & Software
- Development Tool Hardware
- Development Kit
- Learning Board
- Programmer
- Software**
- Third Party Tool
- Reference Design
- FAQ
- Sales Support
- Technical Support
- Forum

**Click here to enter Software download page**

**Step3**

---

**Programmer Software Tools Package**

File name	Description	Version	Date
ICP Programming Tool V1.25.6287.zip Revision History	NuMicro ICP tool & user manual	V1.25.6287	2014-01-16
ISP Programming Tool V1.44.zip Revision History	NuMicro ISP tool & user manual	V1.44	2014-01-20
NuGang Programmer V6.21.zip Revision History	NuMicro NuGang Programmer user manual	V6.21	2014-01-24

**Step4**

**Nu-Link Driver**

File name	Description	Version	Date
Nu-Link Driver for Keil RVMDK V1.25.6287.zip Revision History	This driver is to support Nu-Link to work under Keil RVMDK Development Environment for all NuMicro Family Devices.	V1.25.6287	2014-01-16
Nu-Link Driver for IAR EWARM V1.25.6287.zip Revision History	This driver is to support Nu-Link to work under IAR EWARM Development Environment for all NuMicro Family Devices.	V1.25.6287	2014-01-16

User Feedback    ↑ TOP

**Step5** Download the NuMicro® Keil μVision® IDE driver.

## 6.2 Downloading NuMicro® IAR EWARM Driver

**Step1** Visit the Nuvoton NuMicro® website: <http://www.nuvoton.com/NuMicro>.

The screenshot shows the Nuvoton website interface. At the top, there is a navigation bar with links for 'Products', 'Applications', 'Support', 'Foundry Service', 'Buy', 'myNuvoton', and 'About Nuvoton'. The 'Support' link is highlighted with a red dashed box and a yellow callout bubble containing the text '2-1. Move to "Support"'. Below the navigation bar, a dropdown menu is open, showing options like 'Learning', 'Product Related Information', 'Tool & Software', 'Reference Design', and 'FAQ'. The 'Tool & Software' option is highlighted with a red dashed box and a yellow callout bubble containing the text '2-2. Click here to enter Tool & Software'. The main content area features a grid of product models categorized by application (Industrial Control, Low Power, USB Application, Automotive Application, Audio Application) and memory size (64K, 32K, 16K). A sidebar on the left lists 'ARM Cortex™-M0 MCUs' and 'Resources'. On the right, there are sections for 'Online Support', 'Featured Products', 'Featured Videos', and 'Featured Applications'.

Register | Login
Language ▾



News | Events | CSR | Human Resources | Investors | Contact Us | Nuvoton Partner

Products
Applications
Support
Foundry Service
Buy
myNuvoton
About Nuvoton

Home > Support > Tool & Software >

**Development Tool Hardware**

- Learning
- Product Related Information
- Tool & Software
- Development Tool Hardware
- Development Kit
- Learning Board
- Programmer
- Software**
- Third Party Tool
- Reference Design
- FAQ
- Sales Support
- Technical Support
- Forum



Evaluation Board



Customer Target Board

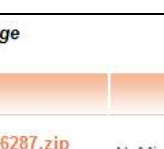

NuTiny Board



KEIL  
Keil RVMDK



IAR  
SYSTIM-IAR EWARM

**Mass Production**

On-Line In Circuit Programming

Customer Target Board

Off-Line In Circuit Programming

Customer Target Board

IC Programming

Nuvoton Gang Programmer

Third Party Writer

**Upgrade**

In System Programming

NuMicro ISP AP

Through

- UART
- USB
- I2C
- SPI
- CAN
- I/O



**NuMicro M4 MCU NUC472**  
with Ethernet MAC

**Events**

Nuvoton Technology Hosts 32-bit Cortex™-M4 Ether... 2014-05-02

2014Q1 Investor Conference 2014-04-24

**News**

Nuvoton Announces Monthly Revenue for May 2014 2014-06-06

**Programmer Software Tools Package**

File name	Description	Version	Date
 ICP Programming Tool V1.25.6287.zip <a href="#">Revision History</a>	NuMicro ICP tool & user manual	V1.25.6287	2014-01-16
 ISP Programming Tool V1.44.zip <a href="#">Revision History</a>	NuMicro ISP Programming Tool & user manual	V1.44	2014-01-20
 NuGang Programmer V6.21.zip <a href="#">Revision History</a>	NuGang Programmer software & user manual	V6.21	2014-01-24

**Nu-Link Driver**

File name	Description	Version	Date
 Nu-Link Driver for Keil RVMDK V1.25.6287.zip <a href="#">Revision History</a>	This driver is to support Nu-Link to work under Keil RVMDK Development Environment for all NuMicro Family Devices.	V1.25.6287	2014-01-16
 Nu-Link Driver for IAR EWARM V1.25.6287.zip <a href="#">Revision History</a>	This driver is to support Nu-Link to work under IAR EWARM Development Environment for all NuMicro Family Devices.	V1.25.6287	2014-01-16

↑ TOP

**Step3** Click here to enter Software download page

**Step4** Click here to download

**Step5** Download the NuMicro® IAR EWARM driver.



### 6.3 Downloading NuMicro® Mini58 Series BSP Software Library

**Step 1** Visit the Nuvoton NuMicro® website: <http://www.nuvoton.com/NuMicro>.

**Step 2**

The screenshot shows the Nuvoton website interface. At the top, there is a navigation bar with 'Products', 'Applications', 'Support', 'Foundry Service', 'Buy', 'myNuvoton', and 'About Nuvoton'. A dropdown menu is open under 'Support', with 'Tool & Software' highlighted. A yellow oval points to this menu item with the text '2-2. Click here to enter Tool & Software'. Another yellow oval points to the 'Support' menu item with the text '2-1. Move to "Support"'. Below the navigation, there is a product matrix chart showing various NuMicro MCUs (NUC100, Nano120, NUC120, NUC230, NUC140, NUC130, M051, Nano102, Nano112, Mini51, NUC220, NUC240, AU9120\*, AU9110) plotted against memory size (16K, 32K, 64K) and application categories (Industrial Control, Low Power, USB Application, Automotive Application, Audio Application). A 'Featured Products' section on the right lists M0516LDE, MINI54FDE, and NANO130KE3BN. A 'Featured Videos' section shows a video titled 'M0 Introduction(06:35)'. At the bottom, there is a note: 'As one of the leading Microcontroller (MCU) companies in the world, Nuvoton provides the state-'. The page footer contains 'July 08, 2015', 'Page 25 of 28', and 'Rev 1.00'.

<p><b>Step 3</b></p>	 <p>The screenshot shows the NuvoTon website's navigation menu. The 'Development Tool Hardware' section is expanded, and the 'Software' link is highlighted with a red dashed box. A yellow callout bubble with a red arrow points to this link, containing the text: 'Click here to enter Software download page'. The website header includes the NuvoTon logo, search bar, and various navigation links like 'Products', 'Applications', 'Support', 'Foundry Service', 'Buy', 'myNuvoTon', and 'About NuvoTon'. The main content area features three columns: 'Development', 'Mass Production', and 'Upgrade', each with sub-sections and images of hardware and software tools.</p>
<p><b>Step 4</b></p>	<p>Download the NuMicro® Mini58 Series CMSIS BSP.</p>

## 7 REVISION HISTORY

Date	Revision	Description
2015.07.08	1.00	1. Preliminary version.

### Important Notice

**Nuvoton Products are neither intended nor warranted for usage in systems or equipment, any malfunction or failure of which may cause loss of human life, bodily injury or severe property damage. Such applications are deemed, “Insecure Usage”.**

**Insecure usage includes, but is not limited to: equipment for surgical implementation, atomic energy control instruments, airplane or spaceship instruments, the control or operation of dynamic, brake or safety systems designed for vehicular use, traffic signal instruments, all types of safety devices, and other applications intended to support or sustain life.**

**All Insecure Usage shall be made at customer’s risk, and in the event that third parties lay claims to Nuvoton as a result of customer’s Insecure Usage, customer shall indemnify the damages and liabilities thus incurred by Nuvoton.**

---

*Please note that all data and specifications are subject to change without notice.  
All the trademarks of products and companies mentioned in this datasheet belong to their respective owners.*