

SPECIFICATIONS

PARAMETERS	VALUES	UNIT
RATED VOLTAGE (SQUARE WAVE)	5	Vp-p
OPERATING VOLTAGE RANGE	3 ~ 8	Vp-p
RATED CURRENT (MAX)	60	mA
COIL RESISTANCE	30 ± 5	OHM
MINIMUM SPL @ 10 CM	80	dB
RESONANT FREQUENCY	2,400 ± 200	Hz
OPERATING TEMPERATURE	-40 ~ +85	°C
STORAGE TEMPERATURE	-50 ~ +95	°C
HOUSING MATERIAL	LCP	-
TERMINAL MATERIAL	Sn PLATED BRASS	-
WEIGHT	0.6	grams

THIS DOCUMENT CONTAINS DATA PROPRIETARY TO PROJECTS UNLIMITED, INC. ANY USE OR REPRODUCTION, IN ANY FORM, WITHOUT PRIOR WRITTEN PERMISSION OF PROJECTS UNLIMITED, INC. IS PROHIBITED.
©2003, Projects Unlimited Inc.

REVISION HISTORY

LTR	DESCRIPTION	DATE	APPROVED
-	RELEASED FROM ENGINEERING	3/29/2007	
A	REVISED MINIMUM SPL @ 10cm	5/16/2007	R.W.
B	REVISED TO INVENTOR 3-D DRAWING TEMPLATE	11/5/2007	B.R.
C	REVISED SPECIFICATIONS	11/8/2011	M.L.

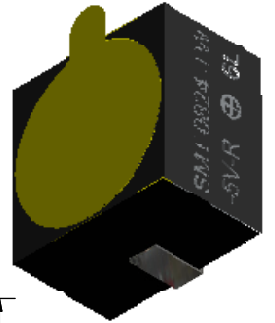
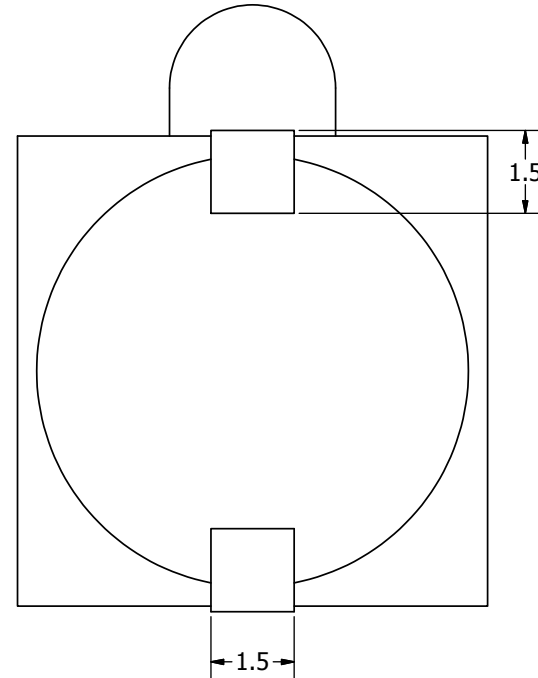
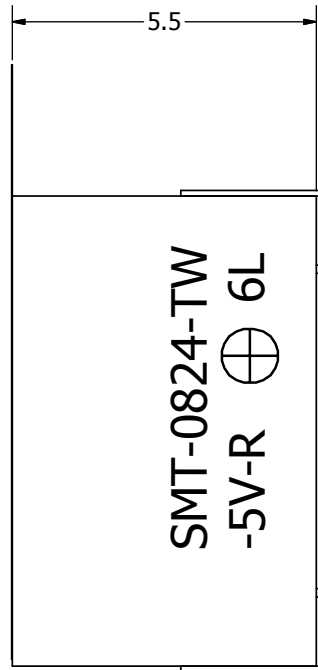
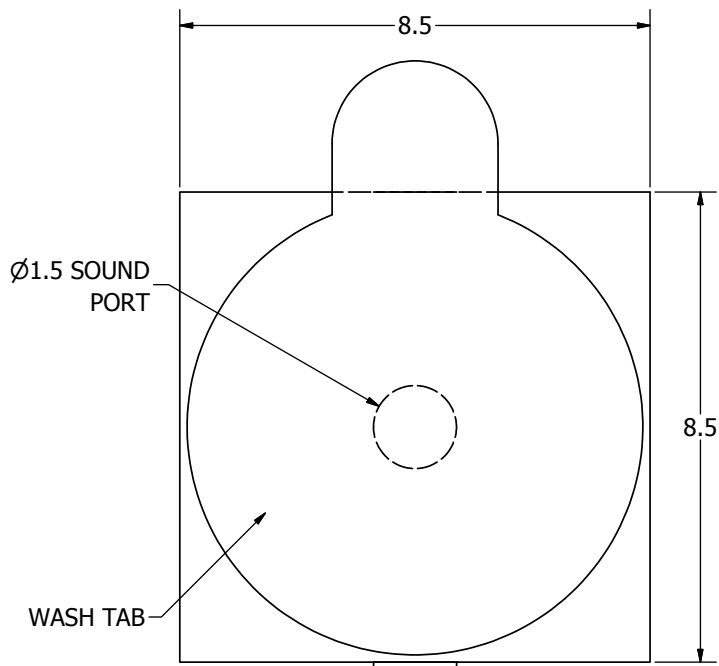

NOTES:

1. ALL DIMENSIONS ARE IN MILLIMETERS.
2. SPECIFICATIONS SUBJECT TO CHANGE OR WITHDRAWAL WITHOUT NOTICE.
3. THIS PART IS RoHS 2002/95/EC COMPLIANT.

UNLESS OTHERWISE SPECIFIED: DIMENSIONS ARE IN MILLIMETERS, TOLERANCES ARE ±0.5 AND ANGLES ARE ±3°.	SIZE A3	Designed by	Date	Checked by	Date	Approved by	Date	Drawn Date	
		J.D.	3/29/2007	D.F.	4/2/2007	R.W.	4/2/2007	11/5/2007	
SMT-0824-TW-5V-R.idw				SMT-0824-TW-5V-R				Edition -	
		Transducer (Electro-Mech)				Sheet 1 / 1			