

**Multimode 850 nm
1.0625 Gbit/s Fibre Channel
1.3 Gigabit Ethernet 1x9 Transceiver**

V23826-K305-Cxx/Cxxx

Features

- Compliant with Fibre Channel and Gigabit Ethernet standard
- Meets mezzanine standard height of 9.8 mm
- Compact integrated transceiver unit with
 - VCSEL transmitter
 - Integrated receiver
 - Duplex SC receptacle
- Class 1 FDA and IEC laser safety compliant
- FDA Accession No. 9520890-18
- Single power supply (5 V or 3.3 V)
- Signal detect indicator (PECL and TTL version)
- PECL differential inputs and outputs
- Process plug included
- Wave solderable and washable with process plug inserted
- For distances of up to 550 m on multimode fiber



Part Number	Voltage	Signal Detect	Input	Output
V23826-K305-C13	5 V	PECL	AC	DC
V23826-K305-C313	3.3 V			
V23826-K305-C53	5 V	TTL	AC	AC
V23826-K305-C353	3.3 V			
V23826-K305-C63 ¹⁾	5 V	PECL	DC	DC
V23826-K305-C363 ¹⁾	3.3 V			
V23826-K305-C73	5 V	PECL	AC	AC
V23826-K305-C373	3.3 V			
Add Suffix to P/N	Shield Options			
-C3	Metallized cover, forward springs			
-C5	Metallized cover, extended forward springs			
-D3	Metallized cover, backward springs			

¹⁾ Standard version.

Pin Configuration

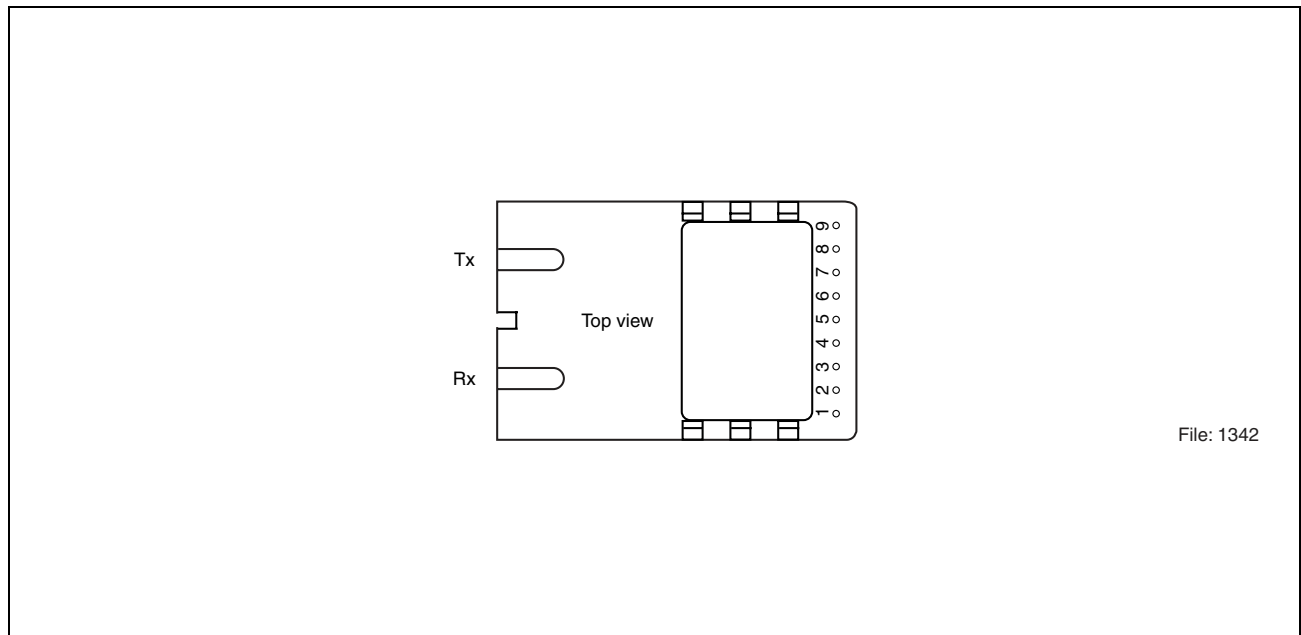

Figure 1

Pin Description

Pin No.	Symbol	Level/Logic	Function	Description
1	$V_{EE}Rx$	Power Supply	Rx Ground	Negative power supply, normally ground
2	RD+	PECL Output	Rx Output Data	Receiver output data
3	RD-			Inverted receiver output data
4	SD	PECL Output active high (TTL C53/C353)	Rx Signal Detect	High level on this output shows there is an optical signal
5	$V_{CC}Rx$	Power Supply	Rx 3.3 V/5 V	Positive power supply, 3.3 V/5 V
6	$V_{CC}Tx$		Tx 3.3 V/5 V	
7	TD-	PECL Input	Tx Input Data	Inverted transmitter input data
8	TD+			Transmitter input data
9	$V_{EE}Tx$	Power Supply	Tx Ground	Negative power supply, normally ground
S1/S2		Mech. Support	Stud Pin	Not connected

Description
Description

The Infineon Fibre Channel / Gigabit Ethernet multimode transceiver – part of Infineon 1x9 family – is based on the Physical Medium Depend (PMD) sublayer and baseband medium, type 1000 Base-SX (short wavelength) as specified in IEEE Std 802.3 and Fibre Channel FC-PI (Rev. 13) 100-M5-SN-I, FC-PI (Rev. 13) 100-M6-SN-I.

The appropriate fiber optic cable is 62.5 µm or 50 µm multimode fiber with Duplex SC connector.

The Infineon multimode transceiver is a single unit comprised of a transmitter, a receiver, and an SC receptacle. This design frees the customer from many alignment and PC board layout concerns.

The module is designed for low cost LAN, WAN, Gigabit Ethernet, and Fibre Channel applications. It can be used as the network end device interface in mainframes, workstations, servers, and storage devices, and in a broad range of network devices such as bridges, routers, intelligent hubs, and local and wide area switches.

This transceiver operates at 1.0625 Gbit/s and 1.3 Gbit/s from a single power supply (5 V or 3.3 V). The full differential data inputs and outputs are PECL compatible.

Link Length as Defined by IEEE and Fibre Channel Standards

Fiber Type	Reach		Unit
	min. ¹⁾	max. ²⁾	
at 1.0625 Gbit/s			
50 µm, 2000 MHz*km	2	860	meters
50 µm, 500 MHz*km	2	500	
50 µm, 400 MHz*km	2	450	
62.5 µm, 200 MHz*km	2	300	
62.5 µm, 160 MHz*km	2	250	
at 1.3 Gbit/s			
50 µm, 500 MHz*km	2	550	meters
50 µm, 400 MHz*km	2	500	
62.5 µm, 200 MHz*km	2	275	
62.5 µm, 160 MHz*km	2	220	

¹⁾ Minimum reach as defined by IEEE and Fibre Channel Standards. A 0 m link length (loop-back connector) is supported.

²⁾ Maximum reach as defined by IEEE and Fibre Channel Standards. Longer reach possible depending upon link implementation.

Functional Description

This transceiver is designed to transmit serial data via multimode cable.

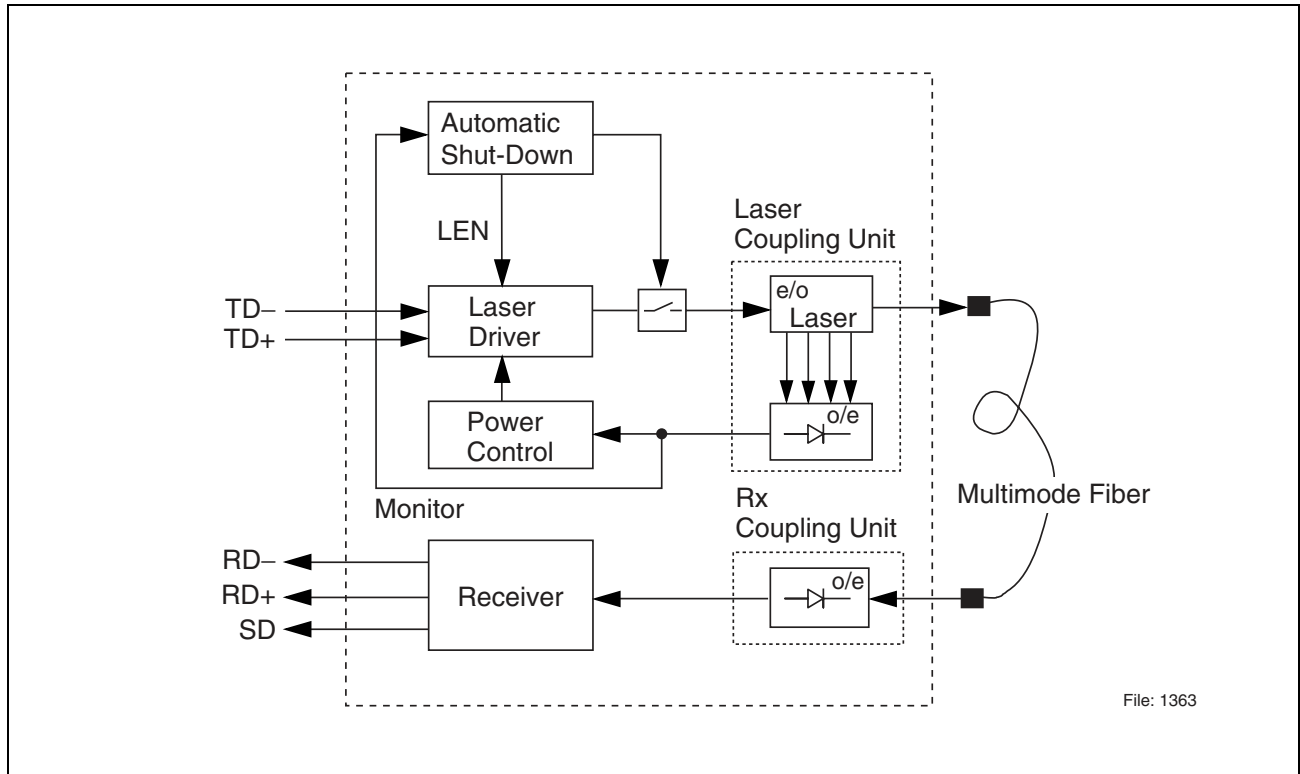

Figure 2 Functional Diagram

The receiver component converts the optical serial data into PECL compatible electrical data (RD+ and RD-). The Signal Detect (SD, active high) shows whether an optical signal is present.

The transmitter converts electrical PECL compatible serial data (TD+ and TD-) into optical serial data.

The following versions are available:

- 1 AC/DC transceiver: Tx is AC coupled. Differential 100 Ω load. Rx has standard PECL output and is DC coupled.
- 2 AC/AC TTL transceiver: Tx and Rx are AC coupled. Tx has differential 100 Ω load. Signal Detect is TTL compatible.
- 3 DC/DC transceiver: Standard PECL inputs and outputs Tx and Rx are DC coupled.
- 4 AC/AC PECL transceiver: Tx and Rx are AC coupled. Tx has differential 100 Ω load. Signal Detect is PECL compatible.

Description

The transmitter contains a laser driver circuit that drives the modulation and bias current of the laser diode. The currents are controlled by a power control circuit to guarantee constant output power of the laser over temperature and aging.

The power control uses the output of the monitor PIN diode (mechanically built into the laser coupling unit) as a controlling signal, to prevent the laser power from exceeding the operating limits.

Single fault condition is ensured by means of an integrated automatic shutdown circuit that disables the laser when it detects transmitter failures. A reset is only possible by turning the power off, and then on again.

The transceiver contains a supervisory circuit to control the power supply. This circuit generates an internal reset signal whenever the supply voltage drops below the reset threshold. It keeps the reset signal active for at least 140 milliseconds after the voltage has risen above the reset threshold. During this time the laser is inactive.

Regulatory Compliance

Feature	Standard	Comments
ESD: Electrostatic Discharge to the Electrical Pins	MIL-STD 883D Method 3015.7 JESD22-A114-B	Class 1 (> 1000 V) HBM Class 1C
Immunity: Electrostatic Discharge (ESD) to the Duplex SC Receptacle	EN 61000-4-2 IEC 61000-4-2	Discharges of ± 15 kV with an air discharge probe on the receptacle cause no damage.
Immunity: Radio Frequency Electromagnetic Field	EN 61000-4-3 IEC 61000-4-3	With a field strength of 3 V/m, noise frequency ranges from 10 MHz to 1 GHz. No effect on transceiver performance between the specification limits.
Emission: Electromagnetic Interference (EMI)	FCC 47 CFR Part 15 Class B EN 55022 Class B CISPR 22	Noise frequency range: 30 MHz to 18 GHz; Margins depend on PCB layout and chassis design.

Technical Data
Absolute Maximum Ratings

Parameter	Symbol	Limit Values		Unit
		min.	max.	
Package Power Dissipation			1.5	W
Supply Voltage	3.3 V 5 V	$V_{CC}-V_{EE}$	5 7	V
Data Input Levels (PECL)			$V_{CC}+0.5$	V
Differential Data Input Voltage			2.5	V
Operating Ambient Temperature		0	70	°C
Storage Ambient Temperature		-40	85	°C
Soldering Conditions Temp/Time (MIL-STD 883C, Method 2003)			250/5.5	°C/s

Exceeding any one of these values may destroy the device immediately.

Recommended Operating Conditions

Parameter	Symbol	Values			Unit
		min.	typ.	max.	
Ambient Temperature	T_{AMB}	0		70	°C
Power Supply Voltage	3.3 V 5 V	$V_{CC}-V_{EE}$	3.1 4.75	3.3 5 3.5 5.25	V
Supply Current ¹⁾	3.3 V 5 V	I_{CC}		230 270	mA

Transmitter

Data Input High Voltage DC/DC	$V_{IH}-V_{CC}$	-1165		-880	mV
Data Input Low Voltage DC/DC	$V_{IL}-V_{CC}$	-1810		-1475	mV
Data Input Differential Voltage ²⁾ AC/DC, AC/AC TTL, AC/AC PECL	V_{DIFF}	250		1600	mV

Receiver

Input Center Wavelength	λ_C	770		860	nm
-------------------------	-------------	-----	--	-----	----

¹⁾ For $V_{CC}-V_{EE}$ (min., max.) 50% duty cycle. The supply current does not include the load drive current of the receiver output. Add. max. 45 mA for the three outputs. Load is 50 Ω to $V_{CC}-2$ V.

²⁾ Version C63: low > 1.2 V; high < $V_{CC}-0.8$ V
Version C363: low > 1.2 V; high < V_{CC}

The electro-optical characteristics described in the following tables are only valid for use under the recommended operating conditions.

Transmitter Electro-Optical Characteristics

Parameter	Symbol	Values			Unit
		min.	typ.	max.	
Launched Power (Average) ¹⁾	P_O	-9.5		-4	dBm
Center Wavelength	λ_C	830	850	860	nm
Spectral Width (RMS)	σ_l			0.85	nm
Relative Intensity Noise	RIN			-117	dB/Hz
Extinction Ratio (Dynamic)	ER	9			dB
Reset Threshold ²⁾	V_{TH}	5 V 3.3 V	3.5 2.7		V
Rise/Fall Time, 20% - 80%	t_R, t_F			0.26	ns
Coupled Power Ratio	CPR	9			dB
Power Dissipation	P_{Dist}	5 V 3.3 V	0.40 0.23	0.62 0.39	W

¹⁾ Into multimode fiber, 62.5 μm or 50 μm diameter.

²⁾ Laser power is shut down if power supply is below V_{TH} and switched on if power supply is above V_{TH} .

Receiver Electro-Optical Characteristics

Parameter	Symbol	Values			Unit	
		min.	typ.	max.		
Sensitivity (Average Power) ¹⁾	P_{IN}		-20	-17	dBm	
Saturation (Average Power)	P_{SAT}			0	dBm	
Signal Detect Assert Level ²⁾	P_{SDA}		-24	-18	dBm	
Signal Detect Deassert Level ³⁾	P_{SDD}	-30	-27		dBm	
Signal Detect Hysteresis	P_{SDA} $-P_{SDD}$		3		dB	
Signal Detect Assert Time	t_{ASS}			100	μs	
Signal Detect Deassert Time	t_{DAS}			350	μs	
Output Low Voltage ⁴⁾	$V_{OL}-V_{CC}$	-1950		-1620	mV	
Output High Voltage ⁴⁾	$V_{OH}-V_{CC}$	-1100		-720	mV	
Signal Detect Output Voltage AC/AC TTL ⁵⁾	Low High	V_{SDL} V_{SDH}		0.5	V	
Data Output Differential Voltage ⁶⁾		V_{DIFF}	0.5	0.8	1.23	V
Output Data Rise/Fall Time, 20% - 80%		t_R, t_F		375	ps	
Return Loss of Receiver		A_{RL}	12		dB	
Power Dissipation	5 V 3.3 V	P_{Disr}		0.63 0.30	0.68 0.42	W

¹⁾ Minimum average optical power at which the BER is less than $1 \times 10E-12$ or lower. Measured with a 2^7-1 NRZ PRBS and ER = 9 dB. Output of multimode fiber 65 μm or 50 μm diameter.

²⁾ An increase in optical power above the specified level will cause the Signal Detect output to switch from a low state to a high state.

³⁾ A decrease in optical power below the specified level will cause the Signal Detect to change from a high state to a low state.

⁴⁾ DC/DC, AC/DC for data. DC/DC, AC/DC, AC/AC PECL for SD. PECL compatible. Load is 50 Ω into $V_{CC}-2$ V for data, 500 Ω to V_{EE} for Signal Detect. Measured under DC conditions. For dynamic measurements a tolerance of 50 mV should be added. $V_{CC} = 3.3$ V/5 V. $T_{AMB} = 25^\circ\text{C}$.

⁵⁾ Max. output current
high: -0.4 mA (drive current)
low: +2 mA (sink current).

⁶⁾ AC/AC for data. Load 50 Ω to GND or 100 Ω differential. For dynamic measurement a tolerance of 50 mV should be added.

Eye Safety

This laser based multimode transceiver is a Class 1 product. It complies with IEC 60825-1/A2: 2001 and FDA performance standards for laser products (21 CFR 1040.10 and 1040.11) except for deviations pursuant to Laser Notice 50, dated July 26, 2001.

CLASS 1 LASER PRODUCT

To meet laser safety requirements the transceiver shall be operated within the Absolute Maximum Ratings.

Note: All adjustments have been made at the factory prior to shipment of the devices. No maintenance or alteration to the device is required. Tampering with or modifying the performance of the device will result in voided product warranty. Failure to adhere to the above restrictions could result in a modification that is considered an act of “manufacturing”, and will require, under law, recertification of the modified product with the U.S. Food and Drug Administration (ref. 21 CFR 1040.10 (i)).

Laser Emission Data

Wavelength	850 nm
Maximum total output power (as defined by IEC: 7 mm aperture at 14 mm distance)	709 μ W / -1.5 dBm
Beam divergence (full angle) / NA (half angle)	20° / 0.18 rad

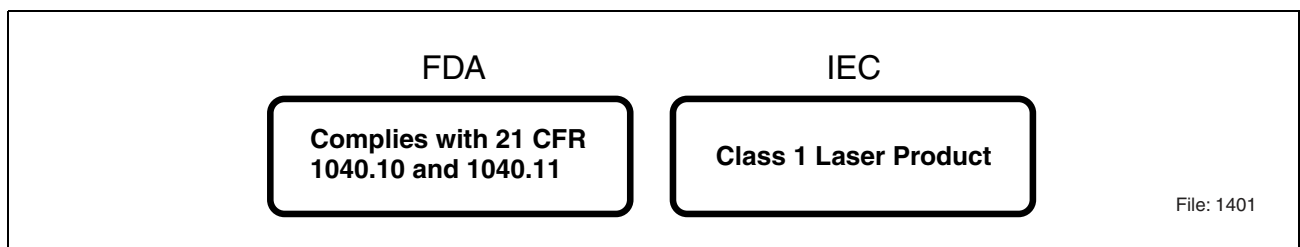

Figure 3 Required Labels

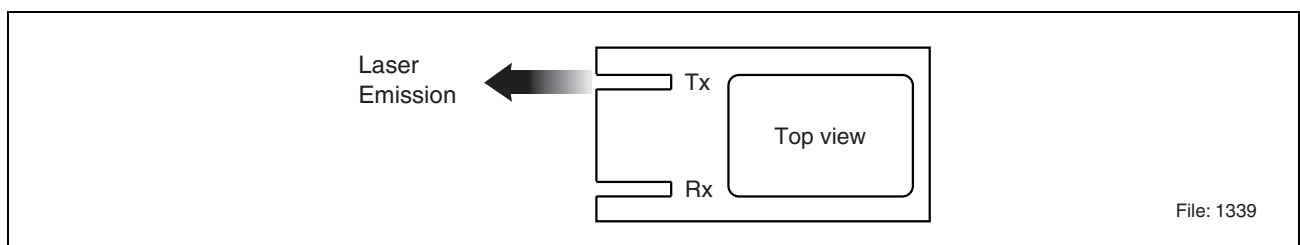

Figure 4 Laser Emission

Application Notes

Gigabit transceivers and matching circuits are high frequency components and shall be terminated as recommended in the application notes for proper EMI performance. Electromagnetic emission may be caused by these components.

To prevent emissions it is recommended that cutouts for the fiber connectors be designed as small as possible.

It is strongly recommended that the Tx plug and the Rx plug be separated with a bar that divides the duplex SC opening.

If shielded parts are employed, they should be in proper contact with the bezel (back plane).

Since the shield is galvanically isolated from signal ground it is strongly recommended to prevent any contact between shield and the circuitry i.e. even any ground connection on the pcb may be harmful to EMI performance.

In cases where EMI performance becomes critical it has proven to be helpful when using SC-plugs with less metal parts inside (as Infineon fibers).

Multimode 850 nm Gigabit Ethernet/Fibre Channel 1x9 Transceiver, DC/DC Version

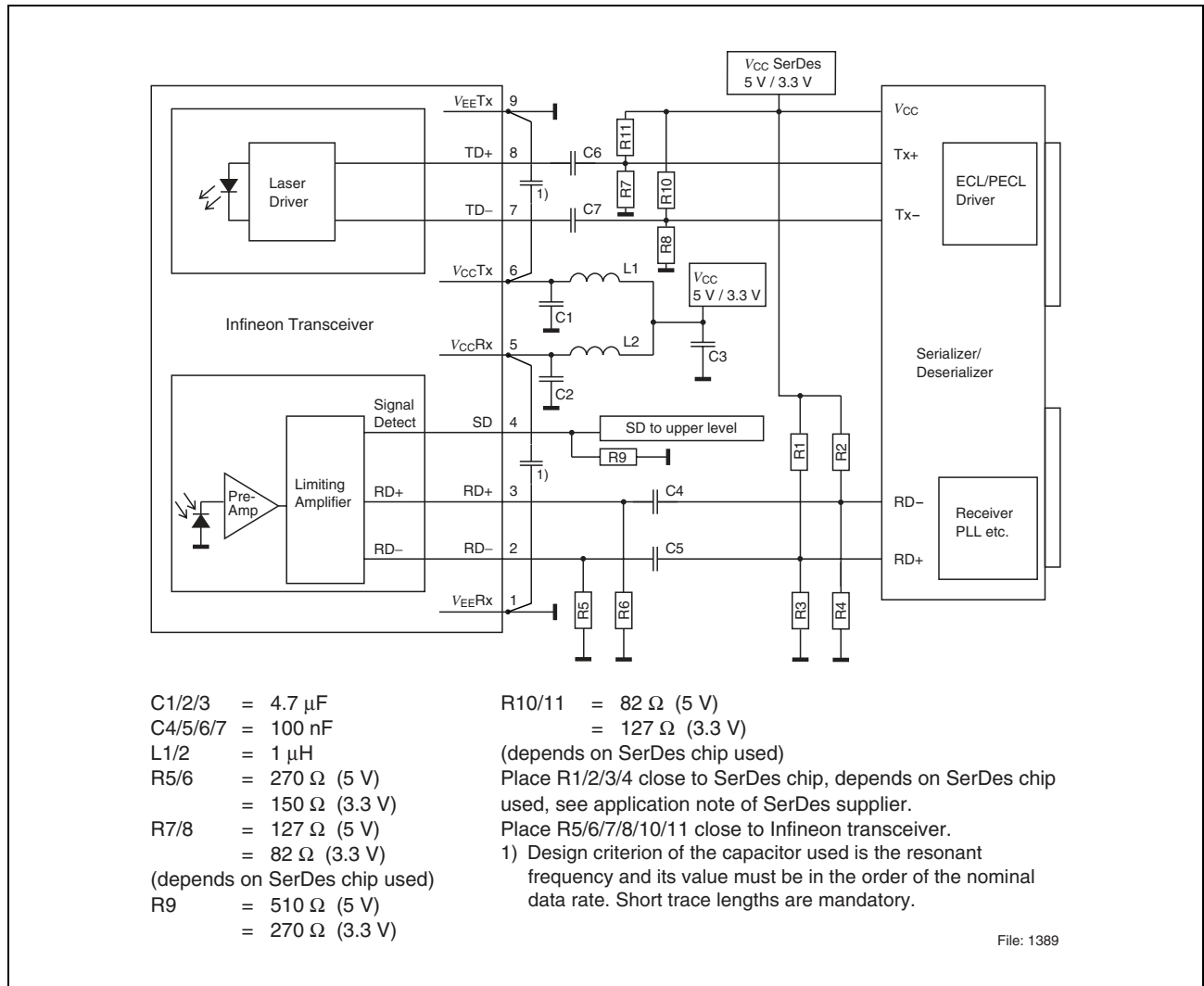

Figure 5

This Application Note assumes Fiber Optic Transceivers using 5 V power supply and SerDes Chips using 3.3 V power supply. It also assumes self biasing at the receiver data inputs (RD+/RD-) of the SerDes chip. Refer to the manufacturer data sheet for other applications. 3.3 V-Transceivers can be directly connected to SerDes-Chips using standard PECL Termination network.

Value of R1 may vary as long as proper 50 Ω termination to V_{EE} or 100 Ω differential is provided. The power supply filtering is required for good EMI performance. Use short tracks from the inductor L1/L2 to the module $V_{CC}Rx/V_{CC}Tx$.

The transceiver contains an automatic shutdown circuit. Reset is only possible if the power is turned off, and then on again. ($V_{CC}Tx$ switched below V_{TH}).

Application Board available on request.

Multimode 850 nm Gigabit Ethernet/Fibre Channel 1x9 Transceiver, AC/DC Version

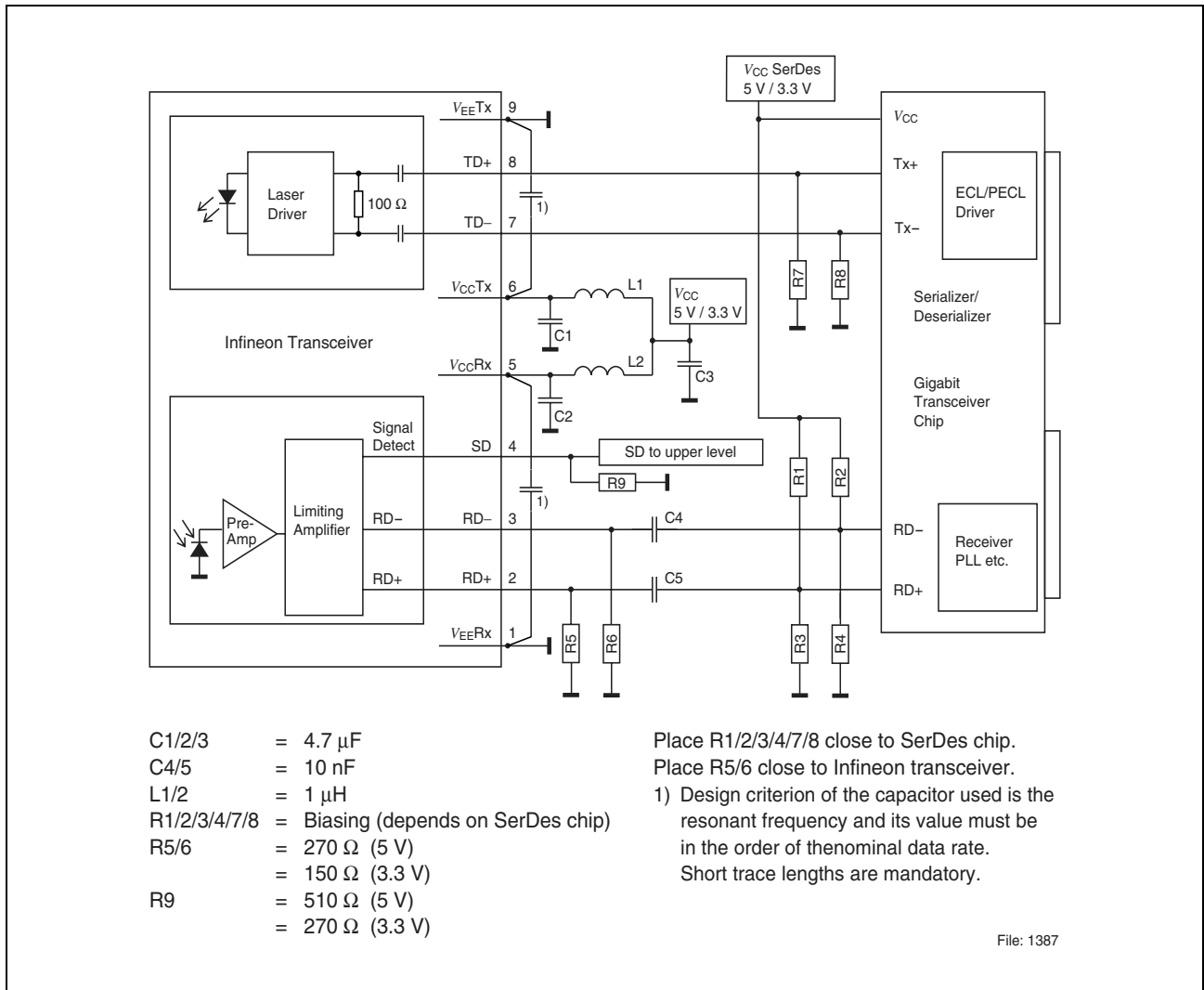

Figure 6

Values of R1/2/3/4 may vary as long as proper 50 Ω termination to V_{EE} or 100 Ω differential is provided. The power supply filtering is required for good EMI performance. Use short tracks from the inductor L1/L2 to the module V_{CC}Rx/V_{CC}Tx.

The transceiver contains an automatic shutdown circuit. Reset is only possible if the power is turned off, and then on again. (V_{CC}Tx switched below V_{TH}).

Application Board available on request.

Multimode 850 nm Gigabit Ethernet/Fibre Channel 1x9 Transceiver, AC/AC TTL and AC/AC PECL Versions

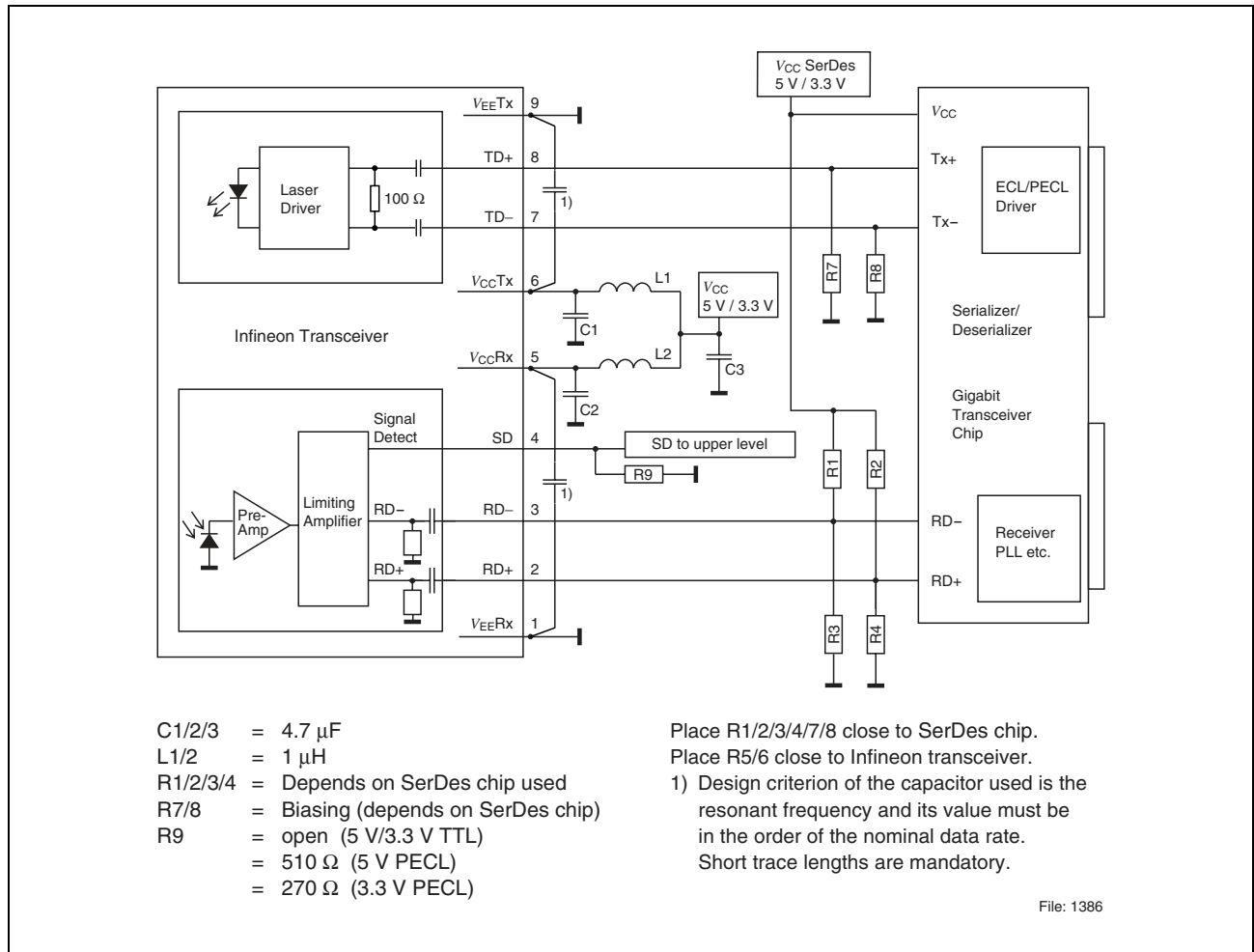

Figure 7

Values of $R1/2/3/4$ may vary as long as proper 50 Ω termination to V_{EE} or 100 Ω differential is provided. The power supply filtering is required for good EMI performance. Use short tracks from the inductor $L1/L2$ to the module $V_{CC}Rx/V_{CC}Tx$.

The transceiver contains an automatic shutdown circuit. Reset is only possible if the power is turned off, and then on again. ($V_{CC}Tx$ switched below V_{TH}).

Application Board available on request.

Shield Options

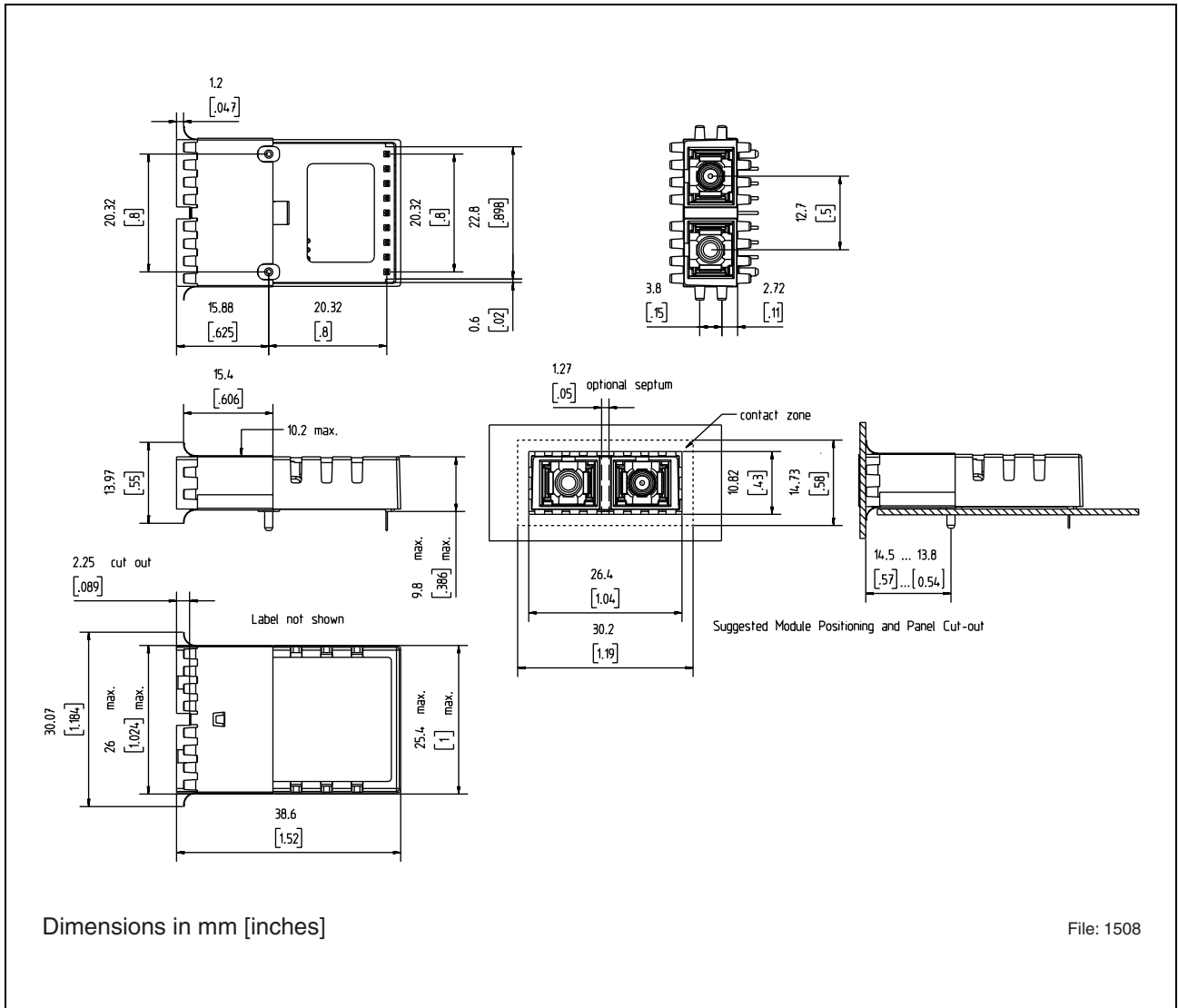

Figure 8 -C3 Shield with Forward Springs

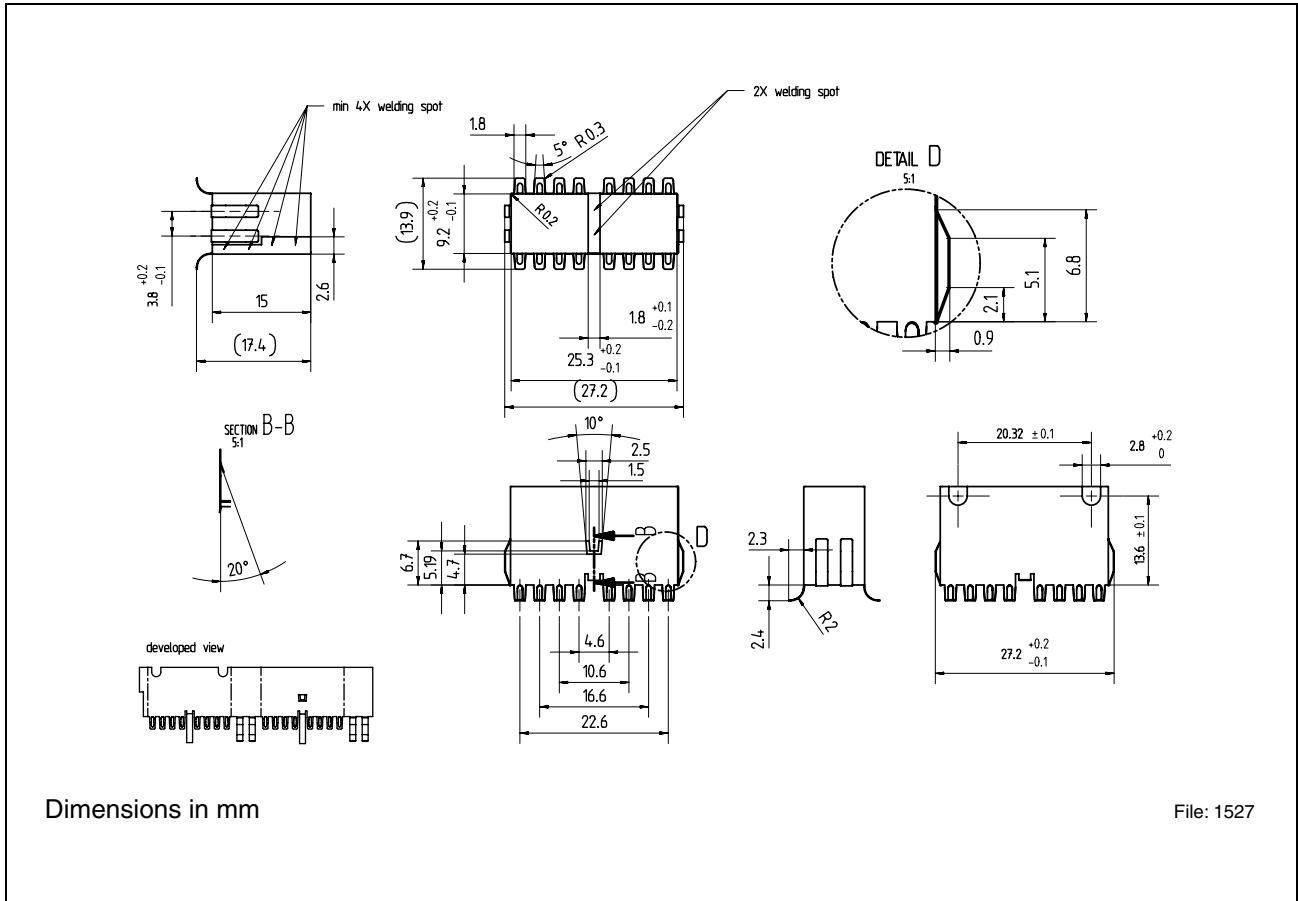

Figure 9 -C5 Shield with Extended Forward Springs

Shield Options

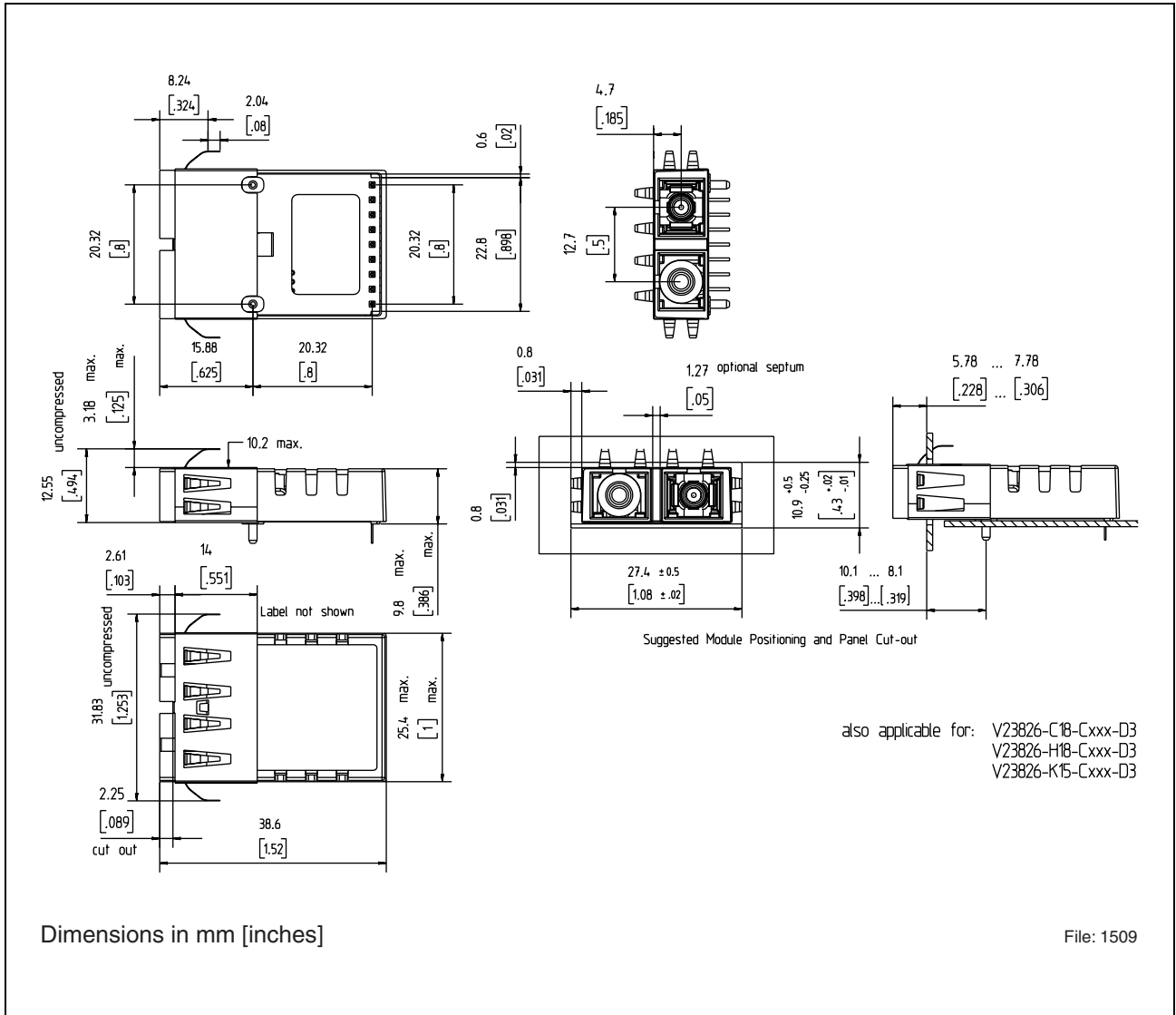

Figure 10 -D3 Shield with Backward Springs

Package Outlines

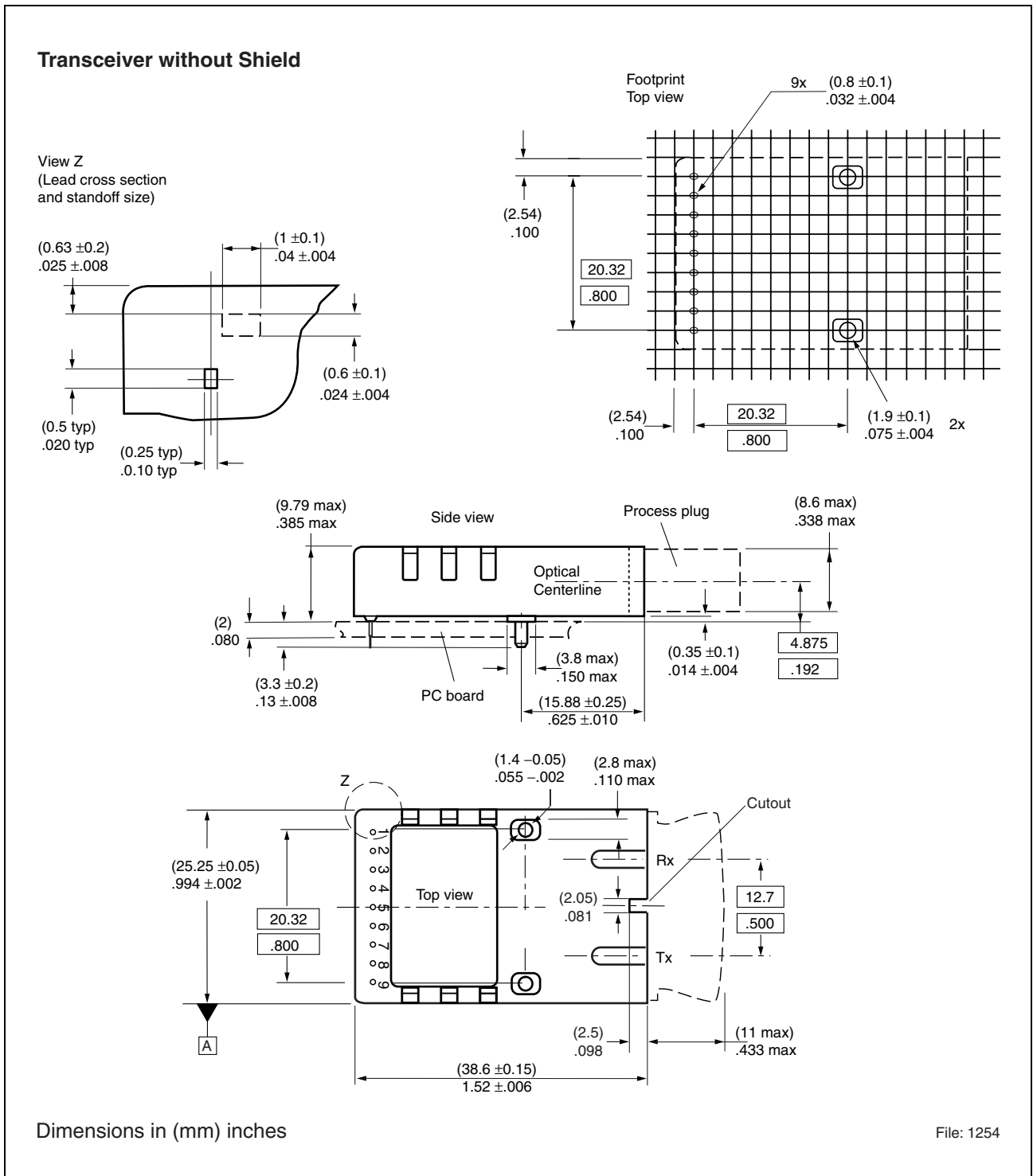

Figure 11

Revision History: 2004-10-29

DS2

Previous Version: 2004-01-27

Page	Subjects (major changes since last revision)
	Shield option -C5 added
3	Description changed
9	Eye Safety changed Table " Laser Emission Data " changed
15	Figure 9 -C5 Shield with Extended Forward Springs added

Edition 2004-10-29**Published by Infineon Technologies AG,
St.-Martin-Strasse 53,
81669 München, Germany****© Infineon Technologies AG 2004.
All Rights Reserved.****Attention please!**

The information herein is given to describe certain components and shall not be considered as a guarantee of characteristics.

Terms of delivery and rights to technical change reserved.

We hereby disclaim any and all warranties, including but not limited to warranties of non-infringement, regarding circuits, descriptions and charts stated herein.

Information

For further information on technology, delivery terms and conditions and prices please contact your nearest Infineon Technologies Office (www.infineon.com).

Warnings

Due to technical requirements components may contain dangerous substances. For information on the types in question please contact your nearest Infineon Technologies Office.

Infineon Technologies Components may only be used in life-support devices or systems with the express written approval of Infineon Technologies, if a failure of such components can reasonably be expected to cause the failure of that life-support device or system, or to affect the safety or effectiveness of that device or system. Life support devices or systems are intended to be implanted in the human body, or to support and/or maintain and sustain and/or protect human life. If they fail, it is reasonable to assume that the health of the user or other persons may be endangered.