

- 1 MATERIAL:  
BASE: THERMOPLASTIC POLYESTER, UL 94V-0 (NATURAL).  
POST: COPPER ALLOY (GOLD PLATED, .000030 MIN THK).
- 2 ONE HOLE MAY BE UNDERSIZED (.032 - .035 DIA) FOR ASSEMBLY RETENTION DURING WAVE SOLDERING.
- 3 PARTS MUST COMPLY WITH AMP SOLDERABILITY SPEC 109-11-2.
- 4 PLASTIC AROUND POST PERMISSIBLE IN THIS AREA ONLY.
- 5 DIMENSION APPLIES WHEN HEADER IS HELD FLAT.
- 6 MEASURED AT -A-
- 7 COORDINATE DIMENSION APPLIES FROM CENTER OF ACTUAL FEATURE.
- 8 RADIUS AT TIP PERMITTED, BOTH ENDS.
- 9 POST MUST WITHSTAND 3.0 LB (13 NEWTONS) MIN AXIAL FORCE IN BOTH DIRECTIONS WITHOUT DISLODGING.
- 10 TOLERANCES APPLY TO SOLDER SIDE OF BOARD.
- 11 DIMENSION SHOULD BE .060 MIN WHEN MATING WITH A MTA-100 CONNECTOR ASSEMBLY OR A CST-100 CONNECTOR.
- 12 AMP LOGO MAY OR MAY NOT APPEAR ON MOLDING HOUSING.

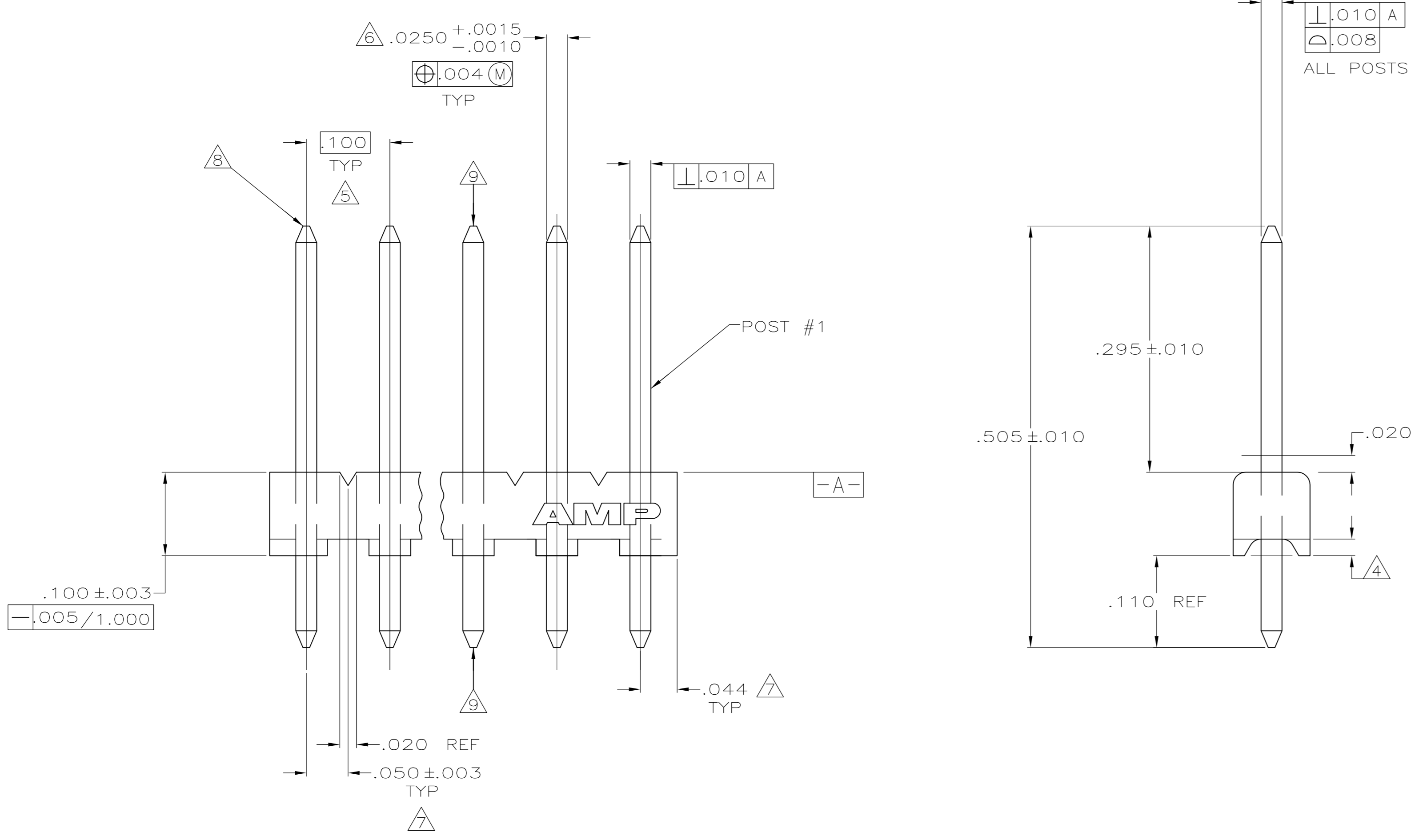

.032	0.81	-	-
.0250	0.635	1.000	25.40
.025	0.64	.505	12.83
.020	0.51	.295	7.49
.010	0.25	.110	2.79
.008	0.20	.100	2.54
.005	0.13	.092	2.34
.004	0.10	.063	1.60
.003	0.08	.060	1.52
.0015	0.038	.050	1.27
.0010	0.025	.044	1.12
.000030	0.00076	.040	1.02
.000	0.00	.035	0.89
IN	MM	IN	MM

CONVERSION TABLE

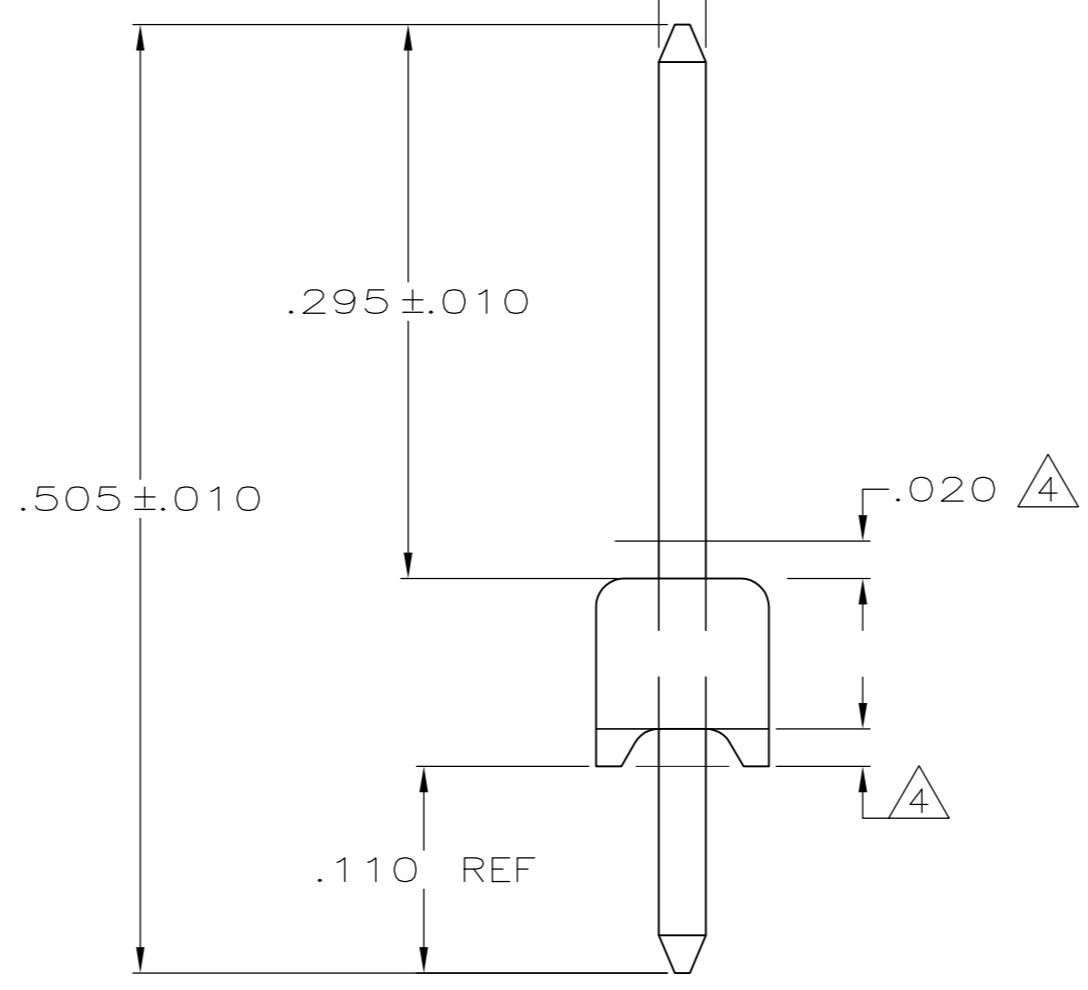
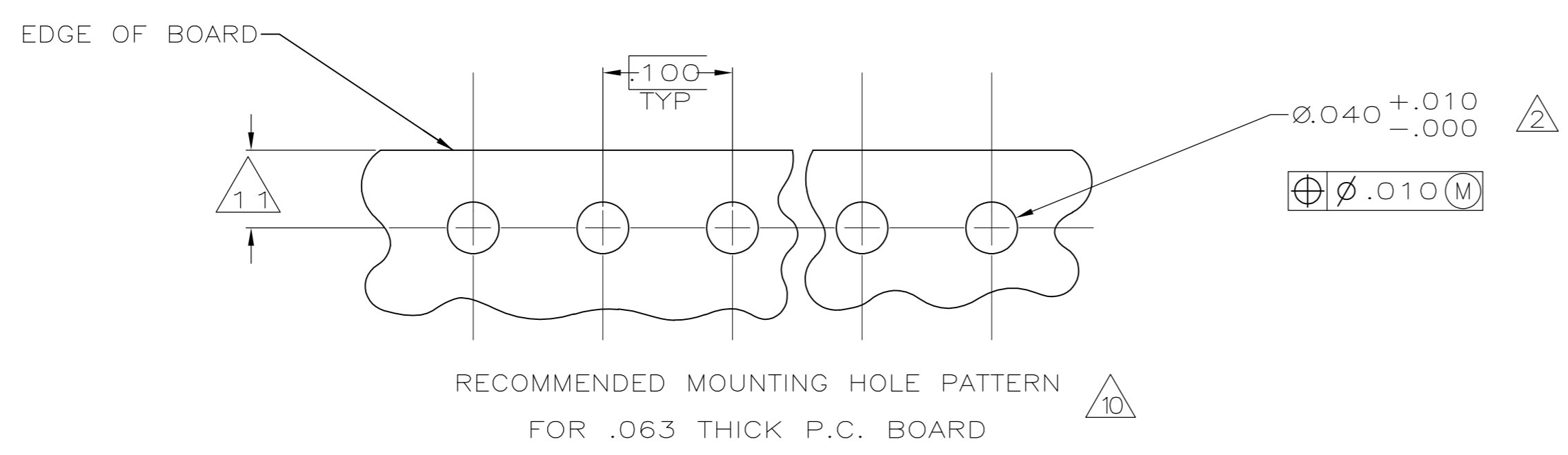

NO. OF POSTS	IN	MM	NO. OF CIRCUITS	PART NUMBER
28	2.788	70.82	28	2-644884-8
27	2.688	68.28	27	2-644884-7
26	2.588	65.74	26	2-644884-6
25	2.488	63.20	25	2-644884-5
24	2.388	60.66	24	2-644884-4
23	2.288	58.12	23	2-644884-3
22	2.188	55.58	22	2-644884-2
21	2.088	53.04	21	2-644884-1
20	1.988	50.50	20	2-644884-0
19	1.888	47.96	19	1-644884-9
18	1.788	45.42	18	1-644884-8
17	1.688	42.88	17	1-644884-7
16	1.588	40.34	16	1-644884-6
15	1.488	37.80	15	1-644884-5
14	1.388	35.26	14	1-644884-4
13	1.288	32.72	13	1-644884-3
12	1.188	30.18	12	1-644884-2
11	1.088	27.64	11	1-644884-1
10	.988	25.10	10	1-644884-0
9	.888	22.56	9	644884-9
8	.788	20.02	8	644884-8
7	.688	17.48	7	644884-7
6	.588	14.94	6	644884-6
5	.488	12.40	5	644884-5
4	.388	9.86	4	644884-4
3	.288	7.32	3	644884-3
2	.188	4.78	2	644884-2

THIS DRAWING IS A CONTROLLED DOCUMENT.

DWN	R. VESTAL	3-27-96
CHK	R. SWING	3-27-96
APP'D	R. WILSON	3-27-96

TE Connectivity

MTA-100 HEADER ASSEMBLY, NARROW, .025 SQUARE STRAIGHT POST, .000030 GOLD PLATED

SIZE: A1 00779 C=644884

CUSTOMER DRAWING SCALE 10:1 SHEET 1 OF 1 REV A1

