

- Surface Mount
- Advanced Process Technology
- Ultra Low On-Resistance
- Dynamic dv/dt Rating
- Fast Switching
- Fully Avalanche Rated
- Lead-Free

HEXFET® Power MOSFET

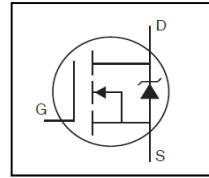

| | |
|---------------------------|---------------|
| V_{DSS} | 55V |
| R_{DS(on)} | 0.045Ω |
| I_D | 3.7A |



| | | |
|----------|----------|----------|
| G | D | S |
| Gate | Drain | Source |

Description

Fifth Generation HEXFETs from International Rectifier utilize advanced processing techniques to achieve extremely low on-resistance per silicon area. This benefit, combined with the fast switching speed and ruggedized device design that HEXFET Power MOSFETs are well known for, provides the designer with an extremely efficient and reliable device for use in a wide variety of applications.

The SOT-223 package is designed for surface-mount using vapor phase, infra red, or wave soldering techniques. Its unique package design allows for easy automatic pick-and-place as with other SOT or SOIC packages but has the added advantage of improved thermal performance due to an enlarged tab for heat sinking. Power dissipation of 1.0W is possible in a typical surface mount application.

| Base Part Number | Package Type | Standard Pack | | Orderable Part Number |
|------------------|--------------|---------------|----------|-----------------------|
| | | Form | Quantity | |
| IRFL4105PbF | SOT-223 | Tape and Reel | 2500 | IRFL4105PbF |

Absolute Maximum Ratings

| Symbol | Parameter | Max. | Units |
|--|---|--------------|-------|
| I _D @ T _A = 25°C | Continuous Drain Current, V _{GS} @ 10V ⑥ | 5.2 | A |
| I _D @ T _A = 25°C | Continuous Drain Current, V _{GS} @ 10V ⑤ | 3.7 | |
| I _D @ T _A = 70°C | Continuous Drain Current, V _{GS} @ 10V ⑤ | 3.0 | |
| I _{DM} | Pulsed Drain Current ① | 30 | |
| P _D @ T _A = 25°C | Maximum Power Dissipation (PCB Mount) ⑥ | 2.1 | W |
| P _D @ T _A = 25°C | Maximum Power Dissipation (PCB Mount) ⑤ | 1.0 | |
| | Linear Derating Factor (PCB Mount) ⑤ | 8.3 | mW/°C |
| V _{GS} | Gate-to-Source Voltage | ± 20 | V |
| E _{AS} | Single Pulse Avalanche Energy (Thermally Limited) ② | 110 | mJ |
| I _{AR} | Avalanche Current ① | 3.7 | A |
| E _{AR} | Repetitive Avalanche Energy ① | 0.10 | mJ |
| dv/dt | Peak Diode Recovery dv/dt ③ | 5.0 | V/ns |
| T _J | Operating Junction and | -55 to + 150 | °C |
| T _{STG} | Storage Temperature Range | | |

Thermal Resistance

| Symbol | Parameter | Typ. | Max. | Units |
|------------------|---|------|------|-------|
| R _{θJA} | Junction-to-Ambient (PCB Mount, steady state) ⑤ | 90 | 120 | °C/W |
| R _{θJA} | Junction-to-Ambient (PCB Mount, steady state) ⑥ | 50 | 60 | |

Electrical Characteristics @ T_J = 25°C (unless otherwise specified)

| | Parameter | Min. | Typ. | Max. | Units | Conditions |
|--------------------------------------|--------------------------------------|------|-------|-------|-------|---|
| V _{(BR)DSS} | Drain-to-Source Breakdown Voltage | 55 | — | — | V | V _{GS} = 0V, I _D = 250μA |
| ΔV _{(BR)DSS/ΔT_J} | Breakdown Voltage Temp. Coefficient | — | 0.058 | — | V/°C | Reference to 25°C, I _D = 1mA |
| R _{DS(on)} | Static Drain-to-Source On-Resistance | — | — | 0.045 | Ω | V _{GS} = 10V, I _D = 3.7A ④ |
| V _{GS(th)} | Gate Threshold Voltage | 2.0 | — | 4.0 | V | V _{DS} = V _{GS} , I _D = 250μA |
| g _{fs} | Forward Trans conductance | 3.8 | — | — | S | V _{DS} = 25V, I _D = 1.9A |
| I _{DSS} | Drain-to-Source Leakage Current | — | — | 25 | μA | V _{DS} = 55 V, V _{GS} = 0V |
| | | — | — | 250 | | V _{DS} = 44V, V _{GS} = 0V, T _J = 150°C |
| I _{GSS} | Gate-to-Source Forward Leakage | — | — | 100 | nA | V _{GS} = 20V |
| | Gate-to-Source Reverse Leakage | — | — | -100 | | V _{GS} = -20V |
| Q _g | Total Gate Charge | — | 23 | 35 | nC | I _D = 3.7A |
| Q _{gs} | Gate-to-Source Charge | — | 3.4 | 5.1 | | V _{DS} = 44V |
| Q _{gd} | Gate-to-Drain Charge | — | 9.8 | 15 | | V _{GS} = 10V, See Fig. 6 and 13 ④ |
| t _{d(on)} | Turn-On Delay Time | — | 7.1 | — | ns | V _{DD} = 28V |
| t _r | Rise Time | — | 12 | — | | I _D = 3.7A |
| t _{d(off)} | Turn-Off Delay Time | — | 19 | — | | R _G = 6.0Ω |
| t _f | Fall Time | — | 12 | — | | R _D = 7.5Ω, See Fig. 10 ④ |
| C _{iss} | Input Capacitance | — | 660 | — | pF | V _{GS} = 0V |
| C _{oss} | Output Capacitance | — | 230 | — | | V _{DS} = 25V |
| C _{rss} | Reverse Transfer Capacitance | — | 99 | — | | f = 1.0MHz, See Fig. 5 |

Source-Drain Ratings and Characteristics

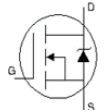
| | Parameter | Min. | Typ. | Max. | Units | Conditions |
|-----------------|--|------|------|------|-------|---|
| I _S | Continuous Source Current (Body Diode) | — | — | 1.3 | A | MOSFET symbol showing the integral reverse p-n junction diode.  |
| I _{SM} | Pulsed Source Current (Body Diode) ① | — | — | 30 | | |
| V _{SD} | Diode Forward Voltage | — | — | 1.3 | V | T _J = 25°C, I _S = 3.7A, V _{GS} = 0V ④ |
| t _{rr} | Reverse Recovery Time | — | 55 | 82 | ns | T _J = 25°C, I _F = 3.7A |
| Q _{rr} | Reverse Recovery Charge | — | 120 | 170 | nC | di/dt = 100A/μs ④ |

Notes:

- ① Repetitive rating; pulse width limited by max. junction temperature. (See fig. 11)
- ② starting T_J = 25°C, L = 16mH, R_G = 25Ω, I_{AS} = 3.7A (See fig. 12)
- ③ I_{SD} ≤ 3.7A, di/dt ≤ 110A/μs, V_{DD} ≤ V_{(BR)DSS}, T_J ≤ 150°C.
- ④ Pulse width ≤ 300μs; duty cycle ≤ 2%.

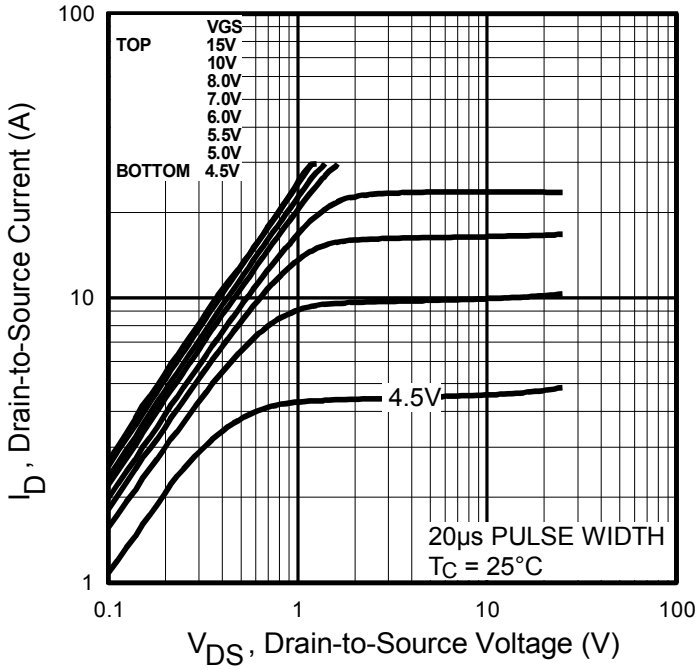
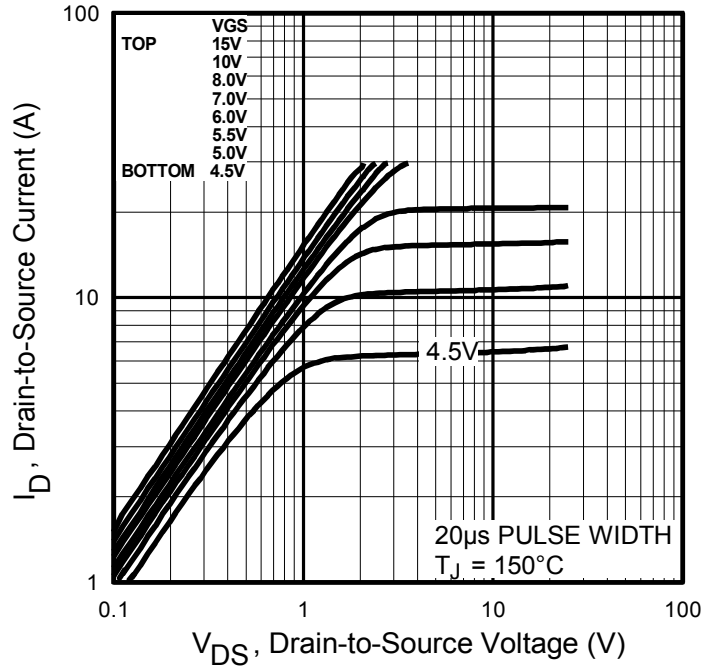
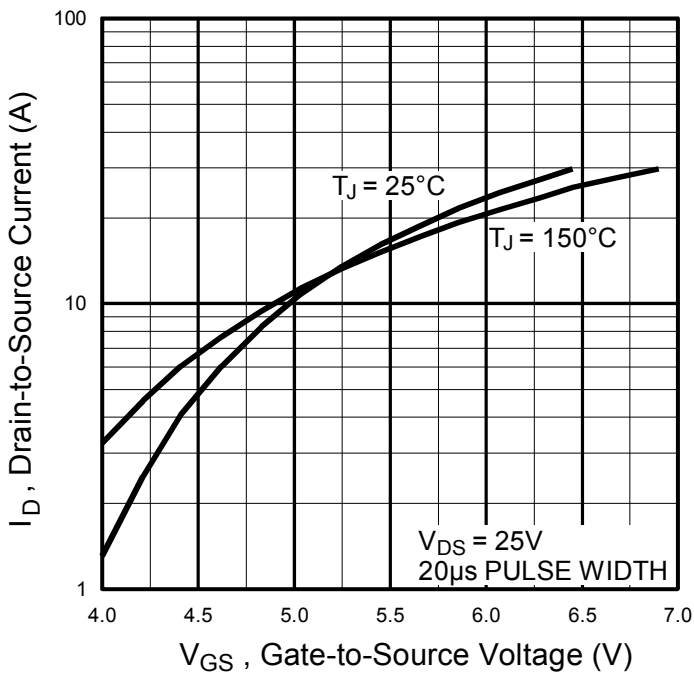
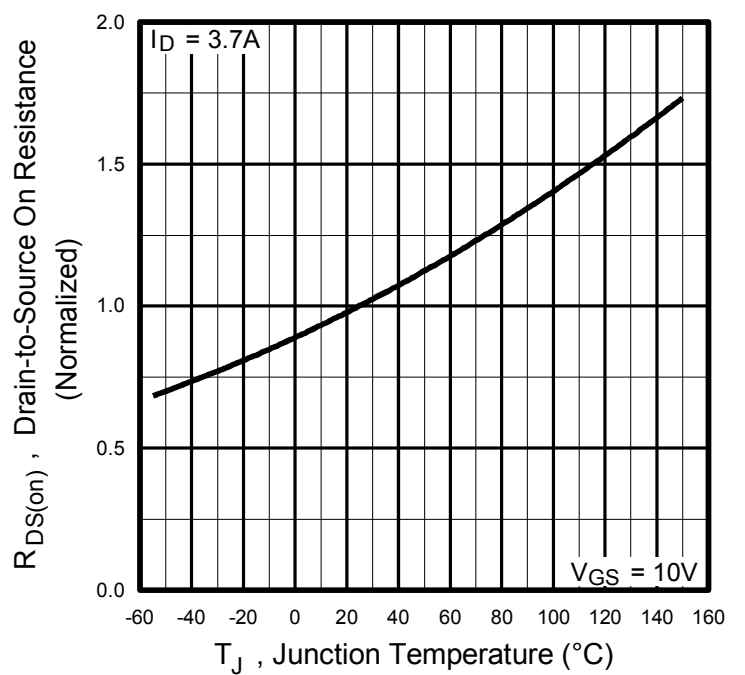
Fig. 1 Typical Output Characteristics

Fig. 2 Typical Output Characteristics

Fig. 3 Typical Transfer Characteristics

Fig. 4 Normalized On-Resistance vs. Temperature

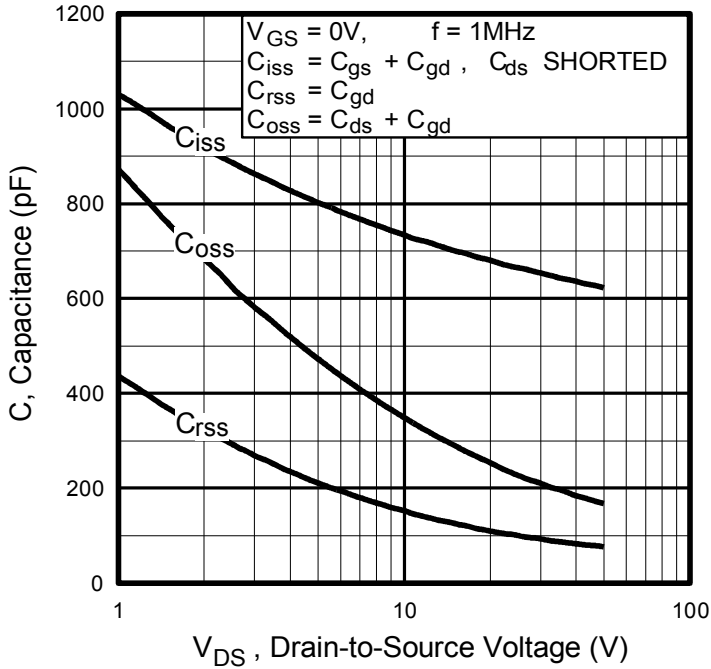

Fig 5. Typical Capacitance vs. Drain-to-Source Voltage

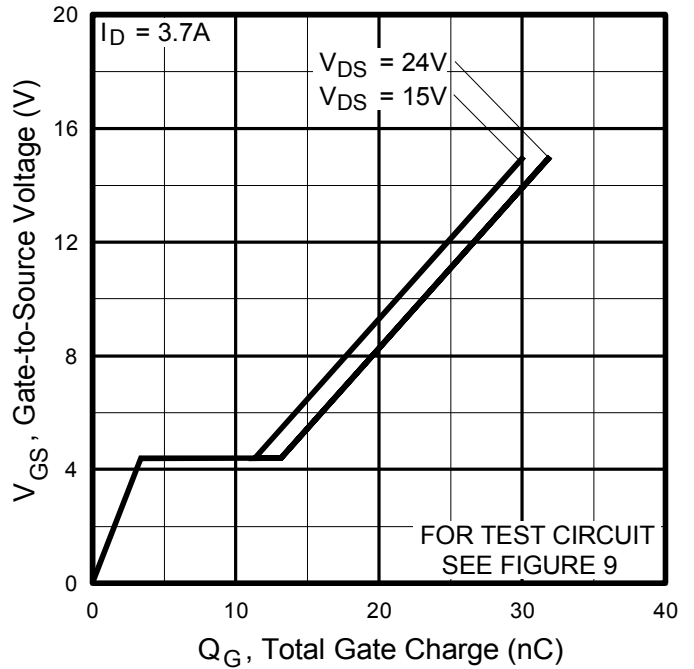

Fig 6. Typical Gate Charge vs. Gate-to-Source Voltage

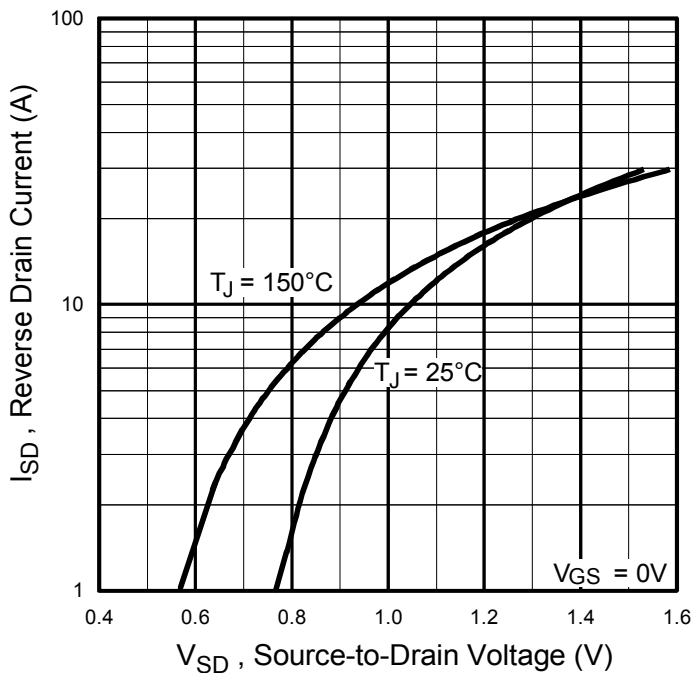

Fig 7 Typical Source-to-Drain Diode Forward Voltage

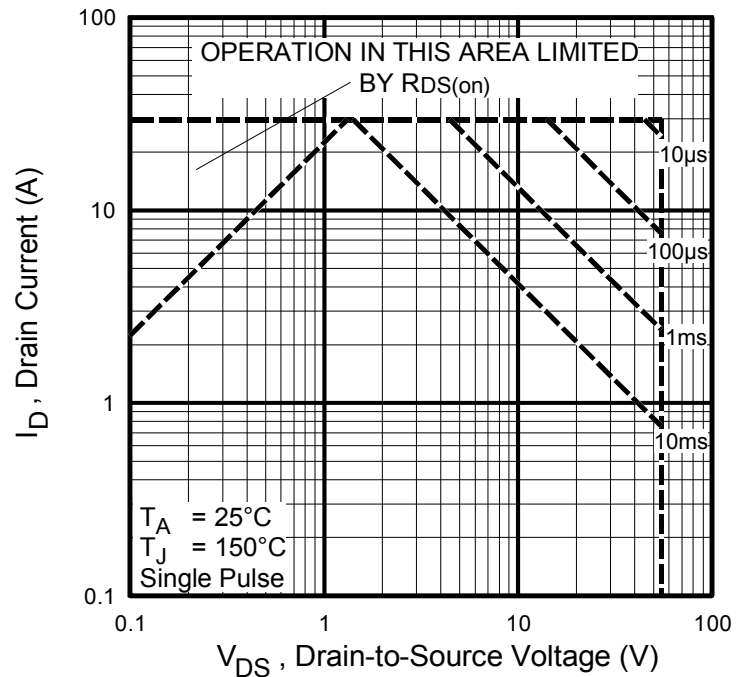
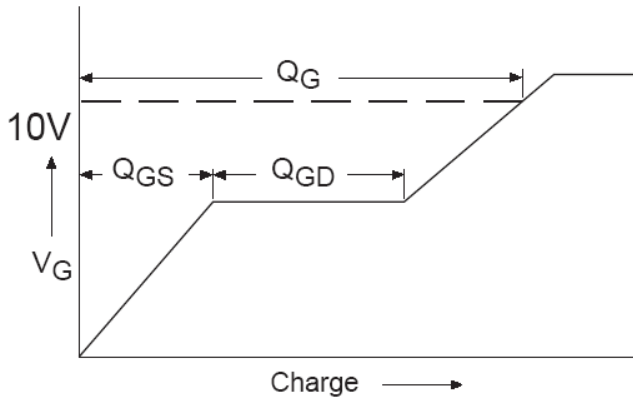
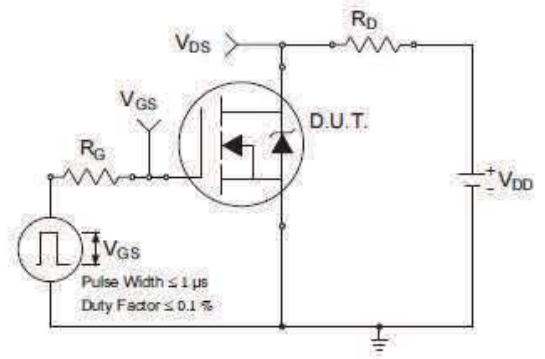
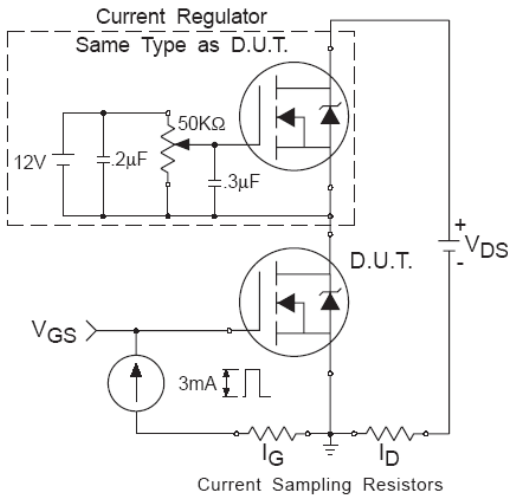
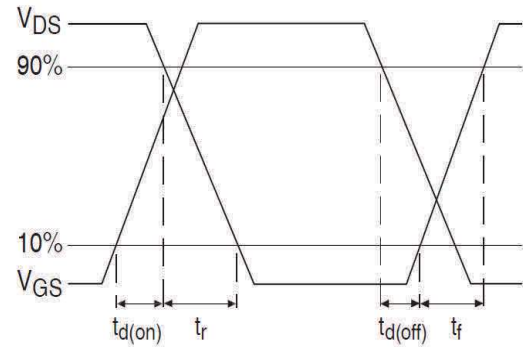
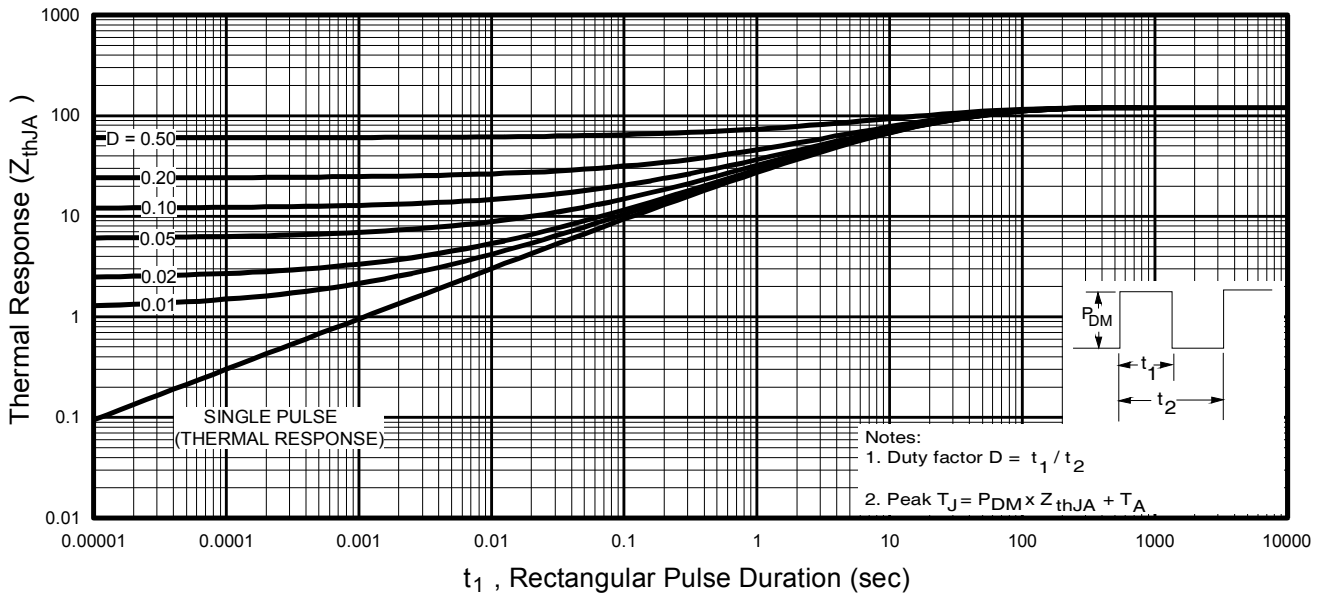
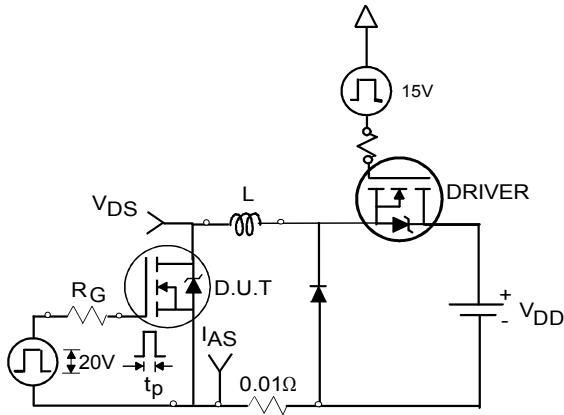
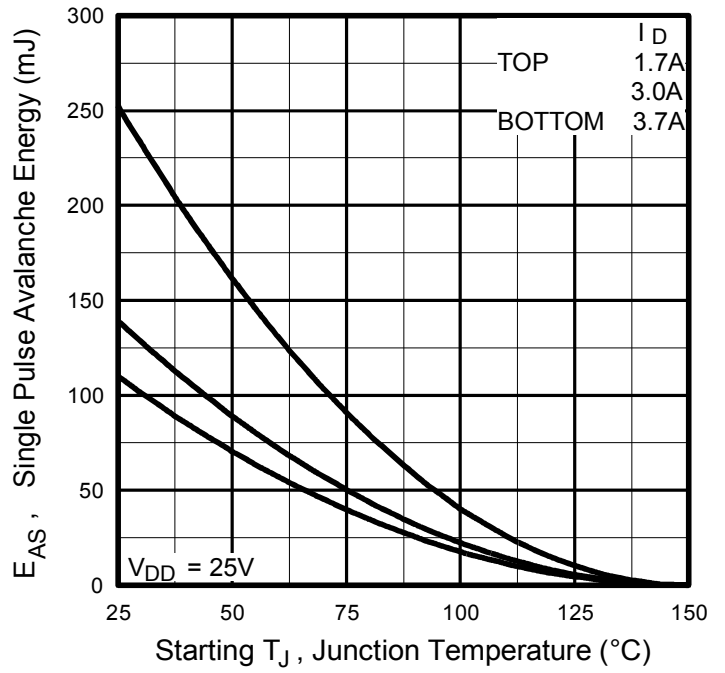
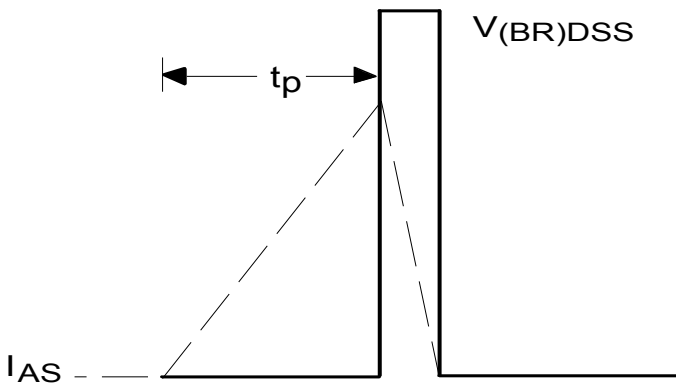

Fig 8. Maximum Safe Operating Area

Fig 9a. Basic Gate Charge Waveform

Fig 10a. Switching Time Test Circuit

Fig 9b. Gate Charge Test Circuit

Fig 10b. Switching Time Waveforms

Fig 11. Maximum Effective Transient Thermal Impedance, Junction-to-Ambient

Fig 12a. Unclamped Inductive Test Circuit

Fig 12c. Maximum Avalanche Energy vs. Drain Current

Fig 12b. Unclamped Inductive Waveforms

Peak Diode Recovery dv/dt Test Circuit

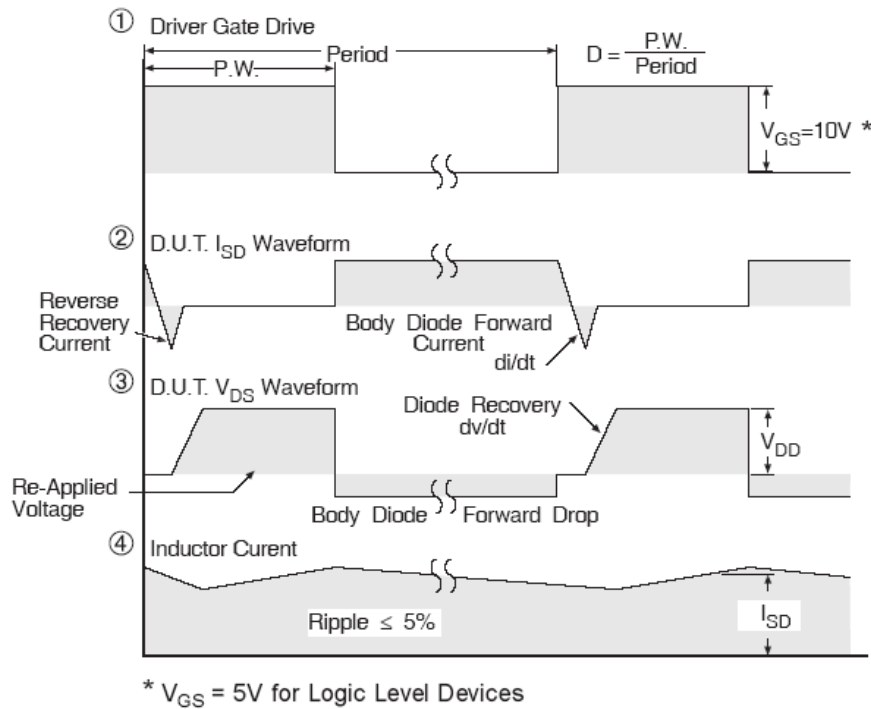
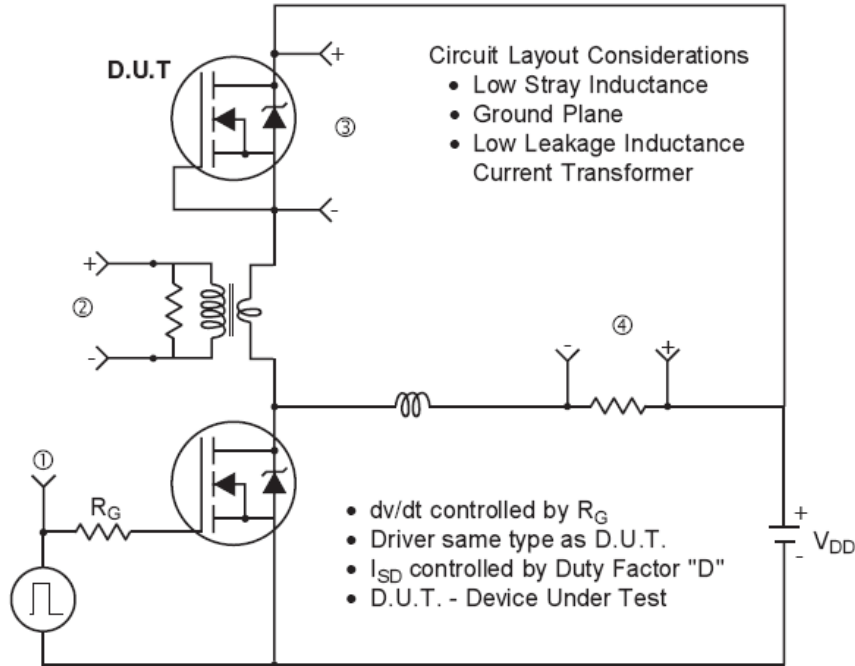
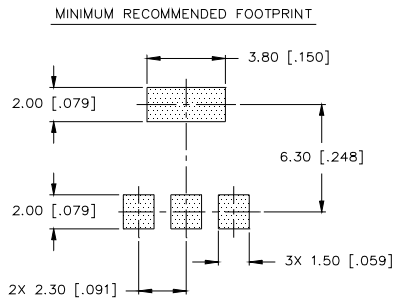
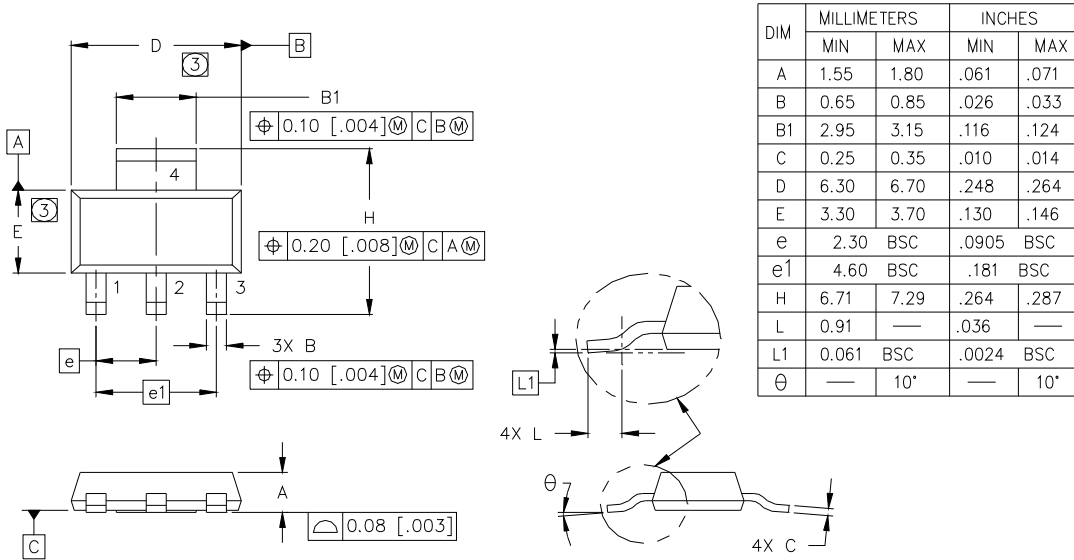

Fig 13. Peak Diode Recovery dv/dt Test Circuit for N-Channel HEXFET® Power MOSFETs

SOT-223 (TO-261AA) Package Outline (Dimensions are shown in millimeters (inches))

LEAD ASSIGNMENTS

- 1 = GATE
- 2 = DRAIN
- 3 = SOURCE
- 4 = DRAIN

NOTES:

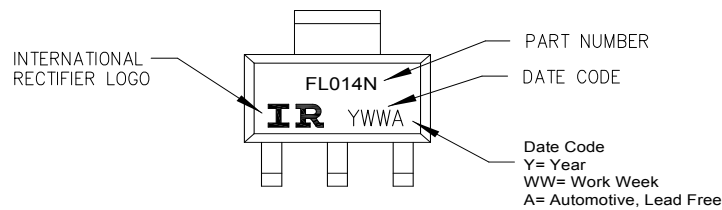
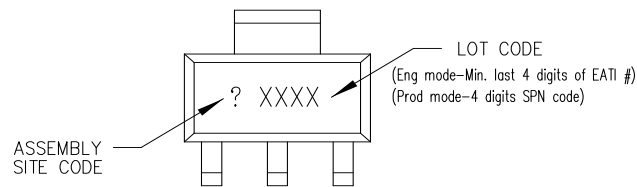
1. DIMENSIONING & TOLERANCING PER ASME Y14.5M-1994.
2. CONTROLLING DIMENSION: INCH.
- ③ DIMENSIONS DO NOT INCLUDE MOLD FLASH.
4. OUTLINE CONFORMS TO JEDEC OUTLINE TO-261AA.
5. DIMENSIONS ARE SHOWN IN MILLIMETERS [INCHES].

SOT-223(TO-261AA) Part Marking Information

TOP MARKING

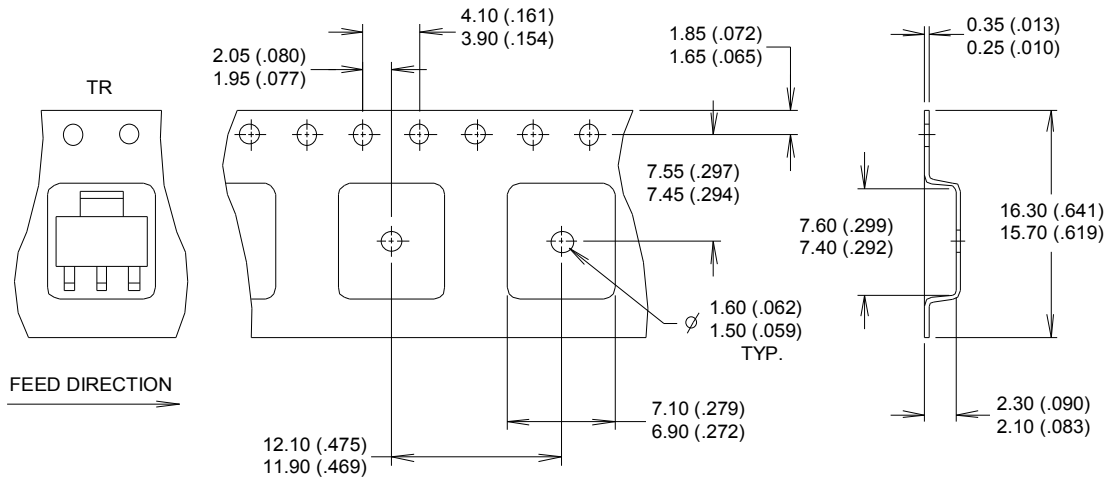
BOTTOM MARKING

Note: For the most current drawing please refer to Infineon's web site www.infineon.com

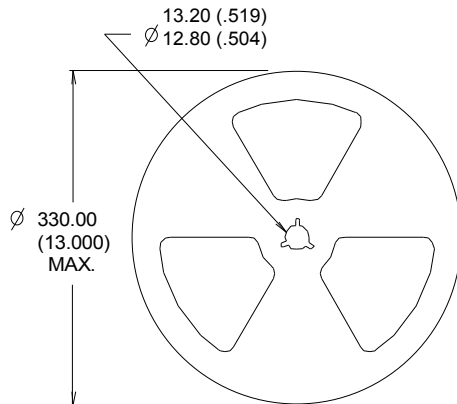
SOT-223(TO-261AA) Tape and Reel (Dimensions are shown in millimeters (inches))

NOTES :

1. CONTROLLING DIMENSION: MILLIMETER.
2. OUTLINE CONFORMS TO EIA-481 & EIA-541.
3. EACH $\varnothing 330.00$ (13.00) REEL CONTAINS 2,500 DEVICES.

NOTES :

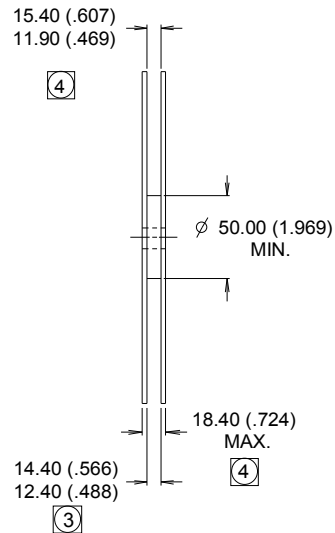
1. OUTLINE COMFORMS TO EIA-418-1.
2. CONTROLLING DIMENSION: MILLIMETER..
- ③ DIMENSION MEASURED @ HUB.
- ④ INCLUDES FLANGE DISTORTION @ OUTER EDGE.



Note: For the most current drawing please refer to Infineon's web site www.infineon.com

Qualification Information[†]

| | | |
|-----------------------------------|---|--|
| Qualification Level | Industrial (per JEDEC JESD47F) ^{††} | |
| Moisture Sensitivity Level | SOT-223 | MSL1 (per JEDEC J-STD-020D) ^{††} |
| RoHS Compliant | Yes | |

† Qualification standards can be found at Infineon's web site www.infineon.com

†† Applicable version of JEDEC standard at the time of product release.

Revision History

| Date | Comments |
|-----------|--|
| 5/27/2016 | <ul style="list-style-type: none"> Updated datasheet with corporate template. Added disclaimer on last page. |

Trademarks of Infineon Technologies AG

μHVIC™, μIPM™, μPFC™, AU-ConvertIR™, AURIX™, C166™, CanPAK™, CIPOS™, CIPURSE™, CoolDP™, CoolGaN™, COOLiR™, CoolMOS™, CoolSET™, CoolSiC™, DAVE™, DI-POL™, DirectFET™, DrBlade™, EasyPIM™, EconoBRIDGE™, EconoDUAL™, EconoPACK™, EconoPIM™, EiceDRIVER™, eupec™, FCOS™, GaNpowIR™, HEXFET™, HITFET™, HybridPACK™, iMOTION™, IRAM™, ISOFACE™, IsoPACK™, LEDrivIR™, LITIX™, MIPAQ™, ModSTACK™, my-d™, NovalithIC™, OPTIGA™, OptiMOS™, ORIGA™, PowIRaudio™, PowIRstage™, PrimePACK™, PrimeSTACK™, PROFET™, PRO-SiL™, RASIC™, REAL3™, SmartLEWIS™, SOLID FLASH™, SPOC™, StrongIRFET™, SupIRBuck™, TEMPFET™, TRENCHSTOP™, TriCore™, UHVIC™, XHP™, XMC™

Trademarks updated November 2015

Other Trademarks

All referenced product or service names and trademarks are the property of their respective owners.

Edition 2016-04-19

Published by

Infineon Technologies AG
81726 Munich, Germany

© 2016 Infineon Technologies AG.
All Rights Reserved.

Do you have a question about this document?

Email: erratum@infineon.com

Document reference

ifx1

IMPORTANT NOTICE

The information given in this document shall in no event be regarded as a guarantee of conditions or characteristics ("Beschaffensgarantie").

With respect to any examples, hints or any typical values stated herein and/or any information regarding the application of the product, Infineon Technologies hereby disclaims any and all warranties and liabilities of any kind, including without limitation warranties of non-infringement of intellectual property rights of any third party.

In addition, any information given in this document is **subject to customer's compliance with its obligations** stated in this document and any applicable legal requirements, norms and standards concerning customer's products and any use of the product of Infineon Technologies in **customer's applications**.

The data contained in this document is exclusively intended for technically trained staff. It is the **responsibility of customer's technical departments** to evaluate the suitability of the product for the intended application and the completeness of the product information given in this document with respect to such application.

For further information on the product, technology, delivery terms and conditions and prices please contact your nearest Infineon Technologies office (www.infineon.com).

Please note that this product is not qualified according to the AEC Q100 or AEC Q101 documents of the Automotive Electronics Council.

WARNINGS

Due to technical requirements products may contain dangerous substances. For information on the types in question please contact your nearest Infineon Technologies office.

Except as otherwise explicitly approved by Infineon Technologies in a written document signed by authorized representatives of Infineon Technologies, **Infineon Technologies' products may not be used** in any applications where a failure of the product or any consequences of the use thereof can reasonably be expected to result in personal injury.