

EH 52,5 F-C SS/ABS-PC GY7035 - Upper part of housing



1074796

<https://www.phoenixcontact.com/us/products/1074796>

Please be informed that the data shown in this PDF document is generated from our online catalog. Please find the complete data in the user documentation. Our general terms of use for downloads are valid.



DIN rail housing, Upper housing part, flat design, connection opening on one side, connection opening on one side, width: 52.6 mm, height: 74.65 mm, depth: 36.95 mm, color: light grey (7035)

Your advantages

- DIN rail or wall mounting for application-specific device attachment
- Easy design-in, thanks to variable housing form factor
- Complete flexibility, thanks to PCBs with horizontal, frontal, and orthogonal orientation to the front of the device
- Three cover versions for individual PCB connections
- Integration of a wide variety of PCB connection technologies for a functional device design

Commercial data

Item number	1074796
Packing unit	1 pc
Minimum order quantity	10 pc
Sales key	AC12
Product key	ACHCHC
GTIN	4055626775586
Weight per piece (including packing)	25.08 g
Weight per piece (excluding packing)	25 g
Customs tariff number	84879090
Country of origin	IN

EH 52,5 F-C SS/ABS-PC GY7035 - Upper part of housing

1074796

<https://www.phoenixcontact.com/us/products/1074796>

Technical data

Notes

General	Refer to the data sheet for the range in the download area.
---------	---

Product properties

Product type	Upper housing part
Product family	EH 52,5
Type	Upper housing part, flat design, connection opening on one side
Housing type	DIN rail housing
Ventilation openings present	yes
Housing series	EH

Dimensions

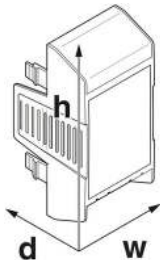
Dimensional drawing	
Width	52.6 mm
Height	74.65 mm
Depth	36.95 mm
Depth from base support surface	19.95 mm

Material specifications

Color	light grey (7035)
Flammability rating according to UL 94	V0
Surface characteristics	untreated
Housing material	ABS-PC

Environmental and real-life conditions

Vibration test

Specification	IEC 60068-2-6:2007-12
Frequency	10 - 150 - 10 Hz
Sweep speed	1 octave/min
Amplitude	0.15 mm (10 Hz ... 58.1 Hz)
Acceleration	2g (58.1 Hz ... 150 Hz)
Test duration per axis	2.5 h
Test directions	X-, Y- and Z-axis

EH 52,5 F-C SS/ABS-PC GY7035 - Upper part of housing



1074796

<https://www.phoenixcontact.com/us/products/1074796>

Glow-wire test

Specification	IEC 60695-2-11:2014-02
Temperature	850 °C
Time of exposure	30 s

Thermal stability / ball thrust test

Specification	IEC 60695-10-2:2014-02
Temperature	80 °C
Test duration	1 h
Force	20 N

Mechanical strength / tumbling barrel

Specification	IEC 60998-1:2002-12
Height of fall	50 cm
Frequency	10

Shocks

Specification	IEC 60068-2-27:2008-02
Pulse shape	Half-sine
Acceleration	15g
Shock duration	11 ms
Number of shocks per direction	3
Test directions	X-, Y- and Z-axis (pos. and neg.)

Degree of protection (IP code)

Specification	IEC 60529:1989-11 + AMD 1:1999-11 + AMD 2:2013-08
---------------	---

Ambient conditions

Max. IP code to attain	IP20
Ambient temperature (operation)	-40 °C ... 80 °C (depending on power dissipation)
Ambient temperature (storage/transport)	-40 °C ... 55 °C
Ambient temperature (assembly)	-5 °C ... 80 °C
Relative humidity (storage/transport)	95 %

PCB data

Type of PCB mount	Slot
-------------------	------

Mounting

Mounting type	Snap in
Mounting position	Vertical (horizontal DIN rail)

Packaging specifications

Type of packaging	packed in cardboard
Outer packaging type	Carton

EH 52,5 F-C SS/ABS-PC GY7035 - Upper part of housing

1074796

<https://www.phoenixcontact.com/us/products/1074796>

Drawings

Dimensional drawing

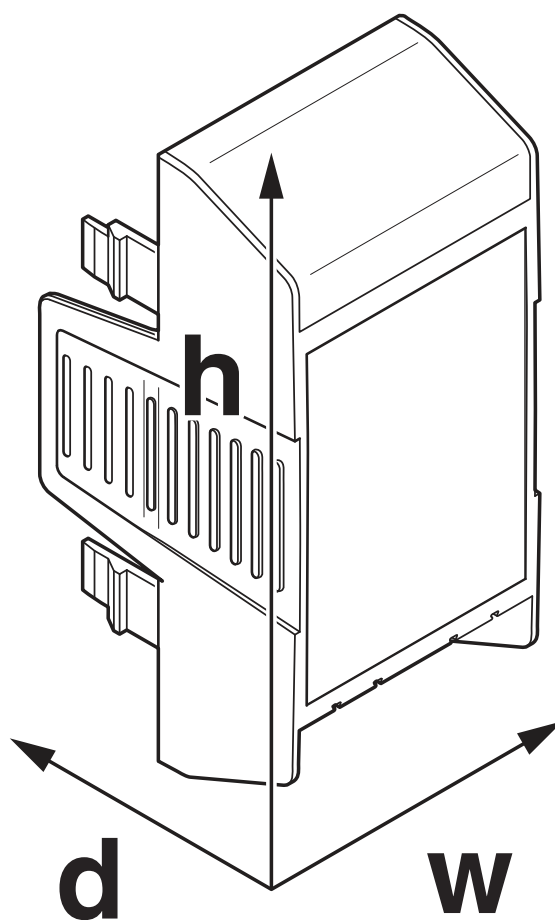

Schematic figure for illustrating the item dimensions. The figure is not of the desired product. For further details, refer to the product drawings in the "Downloads" tab.

EH 52,5 F-C SS/ABS-PC GY7035 - Upper part of housing



1074796

<https://www.phoenixcontact.com/us/products/1074796>

Approvals

To download certificates, visit the product detail page: <https://www.phoenixcontact.com/us/products/1074796>



UL Recognized

Approval ID: FILE E 240868

EH 52,5 F-C SS/ABS-PC GY7035 - Upper part of housing



1074796

<https://www.phoenixcontact.com/us/products/1074796>

Classifications

ECLASS

ECLASS-11.0	27182702
ECLASS-13.0	27190603

ETIM

ETIM 8.0	EC001031
----------	----------

UNSPSC

UNSPSC 21.0	31261500
-------------	----------

EH 52,5 F-C SS/ABS-PC GY7035 - Upper part of housing



1074796

<https://www.phoenixcontact.com/us/products/1074796>

Environmental product compliance

China RoHS	Environmentally friendly use period: unlimited = EFUP-e No hazardous substances above threshold values
------------	---

Phoenix Contact 2023 © - all rights reserved
<https://www.phoenixcontact.com>

Phoenix Contact USA
586 Fulling Mill Road
Middletown, PA 17057, United States
(+717) 944-1300
info@phoenixcon.com