

NOTES:

1. MATERIALS AND FINISHES:

- BODY - BRASS, NICKEL PLATING
- CONTACT - BeCu, SILVER PLATING
- INSULATOR - PTFE, NATURAL
- PIN - BRASS, SILVER PLATING

2. ELECTRICAL:

- A. IMPEDANCE: 50 OHM
- B. FREQUENCY RANGE: DC - 4 GHz
- C. DIELECTRIC WITHSTANDING VOLTAGE: 1500 VRMS, MIN.

3. MECHANICAL:

- A. DURABILITY: 500 CYCLES MIN.
- B. TEMPERATURE RANGE: -65° C TO +165° C

4. PACKAGING:

- A. QUANTITY: 25 PCS/TRAY
- B. MARKING: TRAY TO BE MARKED
"AMPHENOL RF, 18225, AND DATE CODE"

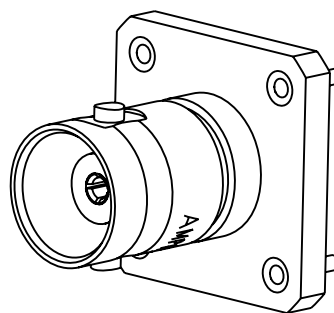

SCALE 2.000

THIRD ANGLE PROJ.

REVISIONS

REV	DESCRIPTION	DATE	ECO	APPR
B	THE BODY WAS CHANGED/RD-DM08092901T	08-Oct-08	--	SH
T	SEE SHEET 1	15-Jun-09	47491	SH
U	REDRAWN IN PRO-E\N/A	23-Apr-15	50266	HHE
V	CHANGE SINGLE PACK TO TRAY PACK \RD-DM17031001S2	10-Mar-17	03262	KEN

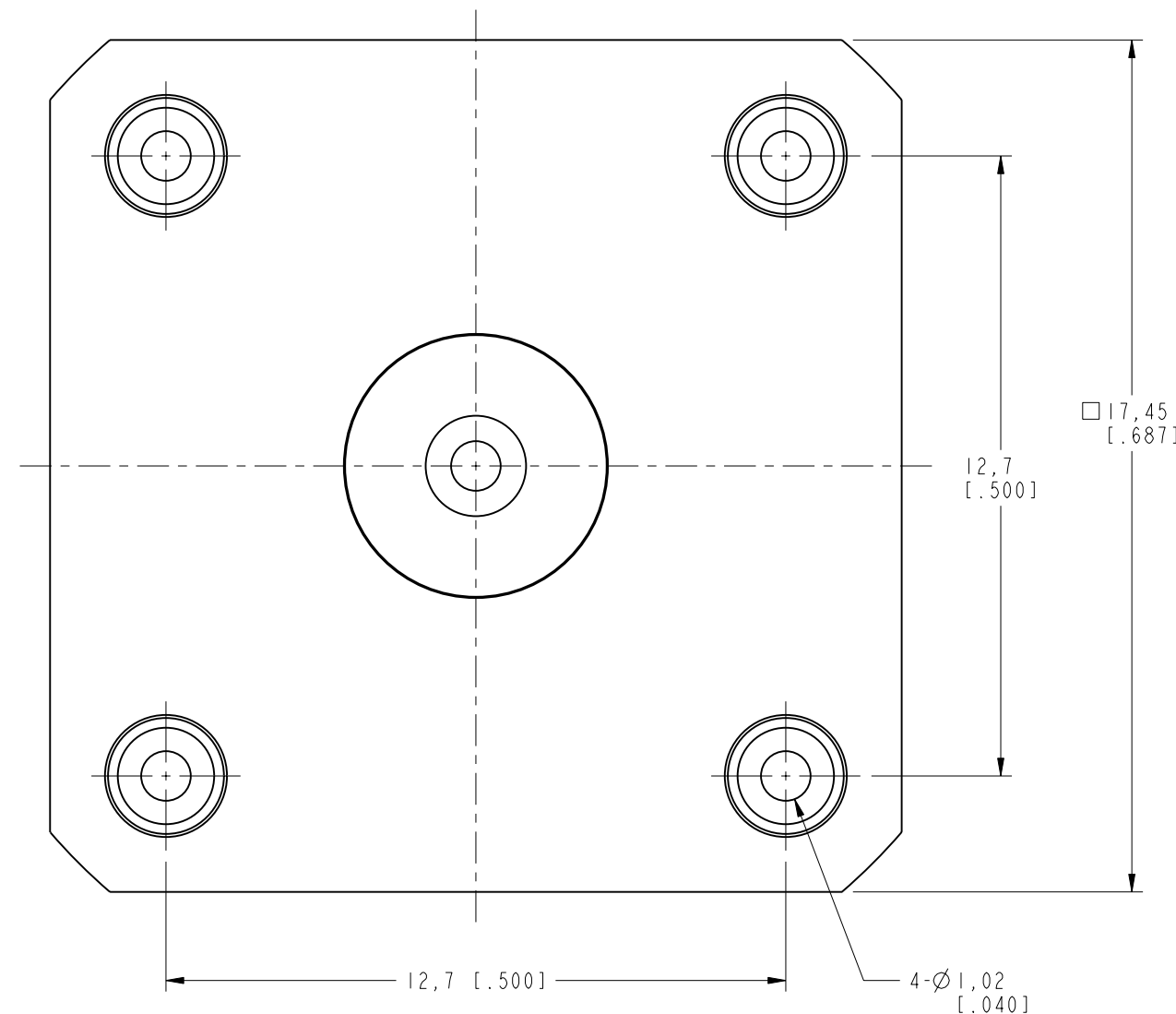
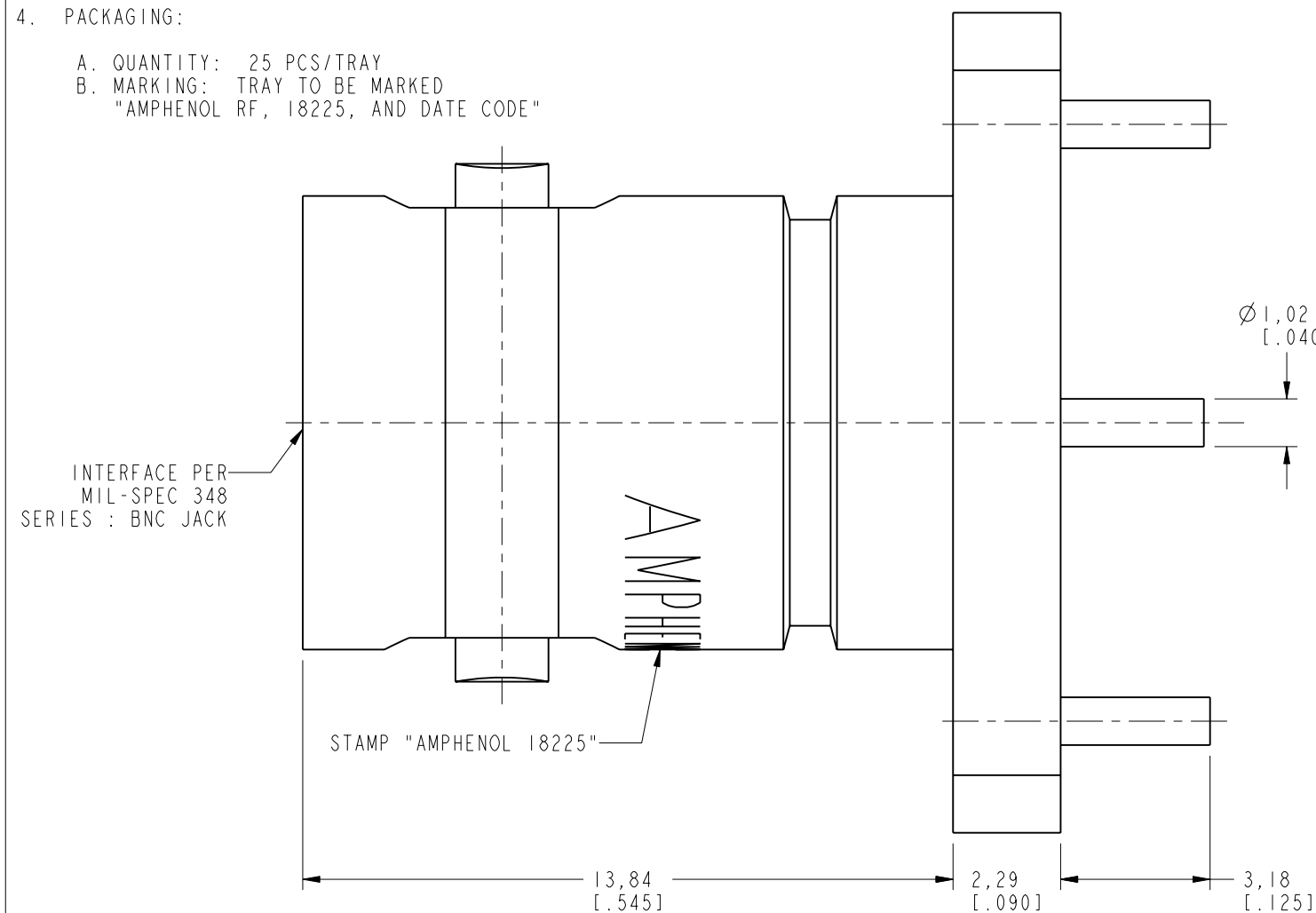

CUSTOMER OUTLINE DRAWING
ALL OTHER SHEETS ARE FOR INTERNAL USE ONLY

<p>UNLESS OTHERWISE SPECIFIED, DIMENSIONS ARE IN METRIC AND TOLERANCES ARE: <0.5mm ±0.05mm 0.5 - 6mm ±0.1mm 6 - 30mm ±0.2mm 30 - 120mm ±0.3mm ANGLES ±1°</p> <p>NOTICE - These drawings, specifications, or other data (1) are, and remain the property of Amphenol corp. (2) must be returned upon request; and (3) are confidential and not to be disclosed to any person other than those to whom they are given by Amphenol Corp. the furnishing of these drawings, specifications, or other data by Amphenol Corp., or to any other person to anyone for any purpose is not to be regarded by implication or otherwise in any manner licensing, granting rights to permitting such holder or any other person to manufacture, use or sell any product, process or design, patented or otherwise, that may in any way be related to or disclosed by said drawings, specifications, or other data.</p>	MATERIAL	DRAWN	DATE	<p>TITLE BNC STR JACK RECEPTACLE FOR PRINTED CIRCUIT</p>	<p>Amphenol RF www.amphenolrf.com</p>
	SEE NOTES	S.DUAN	10-Mar-17		
REFERENCE EAR #	CONFIGURATION LEVEL: In Work	ENGINEER	DATE	<p>SCALE: 7.0:1.0 SHEET 2 OF 2</p>	DRAWING NO. 18225
	FINISH	S.HSIEH	09-Oct-08		ITEM NO. 18225
		APPROVED	DATE	DWG SIZE	PART NO. 18225
		S.HSIEH	20-Mar-17	B	
		CAD FILE		REV	
				V	