

FIBER OPTIC DEMONSTRATION SYSTEM



INDUSTRIAL FIBER OPTICS

*

Copyright © 1996, 1997, 1998, 1999, 2001, 2009
by Industrial Fiber Optics, Inc.
IF 120026 Teacher's Manual Revision A

Printed in the United States of America

* * *

All rights reserved. No part of this publication may be reproduced,
stored in a retrieval system, or transmitted in any form or by any
means (electronic, mechanical, photocopying, recording, or
otherwise) without prior written permission from Industrial Fiber
Optics, Inc.

* * * * *

INDUSTRIAL FIBER OPTICS, INC.
1725 WEST 1ST STREET
TEMPE, AZ 85281-7622
U. S. A.

BEFORE YOU BEGIN . . .

The Industrial Fiber Optics IF-DS100G, *Fiber Optic Demonstration System* is a modular 10-day introduction to fiber optics. It is designed for science, physics, industrial technology, and vocational education classrooms for grades 6-12. This module is a complete curriculum—no additional manuals or books are required except in completing homework assignments, where the library and Internet are adequate.

This manual is an integral part of the IF-DS100G module. It will guide instructors and students through 10 separate activities each of which has reading assignments containing background knowledge and fiber optic theory, lab exercises where one works with fiber optics, worksheets containing questions and homework assignments. At the rear of this manual is an operational and reference guide for the equipment.

As you complete this module, you may be surprised with what constitutes fiber optics. In fact, some of this material contained herein, you may have learned about in other classes or modules. You will learn that fiber optics is not an entirely new technology but rather a combination of three technologies: optics, lasers and electronics. A fiber optic communication system is composed of an optical fiber, transmitter and receiver. The optical fiber is a spin-off of classical optical study. Transmitters and receivers are made from semiconductor materials and technology, making them part of the electronics field. The transmitters of most fiber optic systems use light emitting diodes (LED's) or semiconductor laser diodes. The semiconductor laser is also laser technology and therefore is part of the both electronic and laser field. The curriculum in this manual will cover all the above aspects and have you working with the elements in the matching fiber optic hardware.

Everyone who samples or completes these activities will see fiber optics applied to everyday things and will have a much better appreciation of this new and exciting technology. Please take time to browse through this manual carefully. It contains a wealth of information such as reference materials, vocabulary, advance courses, etc.

Industrial Fiber Optics makes every effort to incorporate state-of-the-art technology, highest quality, and dependability in its products. We constantly explore new ideas and products to best serve the rapidly expanding needs of industry and education. We encourage comments that you may have about our products, and we welcome the opportunity to discuss new ideas that may better serve your needs. For more information about our company and products refer to <http://www.i-fiberoptics.com> on the Worldwide Web.

Thank you for selecting this Industrial Fiber Optics product. We hope it meets your expectations and provides many hours of productive activity.

Table of Contents

Before You Begin.....	i
Activity 1: INTRODUCTION	1
Pretest	2
Laser Safety	5
Laser Classifications	6
Parts List	7
Lab Demonstration #1 - EQUIPMENT FAMILIARIZATION	8
Reading Assignment #1 - INTRODUCTION TO FIBER OPTICS	10
Worksheet #1	12
Activity 2: FIBER OPTICS AT THE BEGINNING	15
Reading Assignment #2 - WHEN DID FIBER OPTICS BEGIN	16
Lab Demonstration #2 - VOICE TRANSMISSION OVER OPTICAL FIBER	20
Worksheet #2	24
Activity 3: APPLICATIONS OF FIBER OPTICS.....	25
Reading Assignment #3 -FIBER OPTICS: WHAT IS IT USED FOR?.....	26
Lab Demonstration #3 - MORSE CODE DIGITAL TRANSMISSION	32
Worksheet #3	39
Activity 4: LIGHT AT THE BEGINNING.....	43
Reading Assignment #4 - LIGHT CHARACTERISTICS AND BEHAVIORS.....	44
Lab Demonstration #4 - AM/FM OPTICAL FIBER TRANSMISSION.	49
Worksheet #4	52
Activity 5: FIBER OPTICS IN OPTICAL SENSORS	55
Reading Assignment #5 - LIGHT AND OPTICAL FIBER INTERACTION	56
Lab Demonstration #5 - FIBER IN ACTIVE & PASSIVE OPTICAL SENSORS.....	58
Worksheet #5	61
Activity 6: CREATION OF LIGHT FOR FIBER OPTICS	65
Reading Assignment #6 - FIBER OPTIC TRANSMITTERS	66
Lab Demonstration #6 - ATTENUATION IN OPTICAL FIBER	71
Worksheet #6	75

Activity 7: FIBER OPTIC RECEIVERS.....	79
Reading Assignment #7 - RECEIVERS FOR FIBER OPTIC SYSTEMS.....	80
Lab Demonstration #7 - TERMINATION AND BENDING LOSSES	86
Worksheet #7	88
Activity 8: EXPAND AND NETWORK.....	91
Reading Assignment #8 - LONG DISTANCES AND FIBER NETWORKS	92
Lab Demonstration #8 - CREATING A FIBER OPTIC REPEATER	97
Worksheet #8	101
Activity 9: FIBER OPTIC TOOLS AND CONNECTORS	105
Reading Assignment #9 - OPTICAL INTERCONNECTIONS AND TOOLS	106
Lab Demonstration #9 - FIBER TERMINATIONS	112
Worksheet #9	116
Activity 10: WRAP UP.....	119
SYSTEM COMPONENTS....	121
REFERENCES.....	124
GLOSSARY.....	127

TEACHER'S MANUAL ONLY

Final Test.....	137
Pretest Answers.....	143
Worksheet Answers.....	146
Final Test Answers.....	167

Section Guide

ACTIVITY 1
Introduction

ACTIVITY 2
Fiber Optics at the Beginning

ACTIVITY 3
Applications of Fiber Optics

ACTIVITY 4
Light at the Beginning

ACTIVITY 5
Fiber Optics in Optical Sensors

ACTIVITY 6
Creation of Light for Fiber Optics

ACTIVITY 7
Fiber Optic Receivers

ACTIVITY 8
Expand and Network

ACTIVITY 9
Fiber Optic Tools and Connectors

ACTIVITY 10
Wrap Up

System Components
References, Glossary

Final Test and Answer Sheets
(Teacher's Manual Only)

INTRODUCTION

ACTIVITY #1:

This activity is intended to get you acquainted with **Industrial Fiber Optics'** *Introduction to Fiber Optics* modular training curriculum. In it you will begin your studies of the fascinating world of fiber optics and familiarize yourself with fiber optic equipment.

Equipment Needed:

- Television monitor and VCR suitable for 1/2" VHS tape
- Laser Technology: Fiber Optics videotape*
- All the components that are part of this module. Please refer to the parts list on page 7 or the detailed description on system components beginning on page 121, Tab 11.

To complete this activity you must:

1. Complete the **Pretest** on pages 2 through 4.
2. Read pages 5 and 6 concerning safety and laser classification.
3. Complete **Lab Demonstration #1 - Equipment Familiarization** on page 9 and take inventory of all the equipment in this module. If you are missing any equipment or parts, let your instructor know before continuing. You may refer to the parts list on page 7 to help describe the components.
4. Watch the videotape entitled Laser Technology: Fiber Optics. (*The tape is an optional item available for purchase with this curriculum.)
5. Answer all Questions on **Worksheet #1** if watched the video tape.
6. Complete **Homework Assignment #1**.

Homework Assignment #1:

Complete **Reading Assignment #1**, which begins on page 10.

Pretest

Student: _____

1. What do the letters in the acronym **LED** stand for?
 - a) Laser emission by defect
 - b) Light emission by diodes
 - c) Light emitting device
 - d) Light emitting diode

2. When light passes from one material to another with a different refractive index, bending of the light rays occurs. This phenomenon was first mathematically described by:
 - a) Howard Maxwell
 - b) Galilei Galileo
 - c) Fred Fresnel
 - d) Willebrord Snell

3. Fiber optics is best known for its application in long-distance telecommunications.
 - a) True
 - b) False

4. Circle the three basic components in a fiber optic communications system.
 - a) Telescope
 - b) Transmitter
 - c) Receiver
 - d) Surveillance satellites
 - e) Maser fiber
 - f) Optical fiber
 - g) Alternator

5. Information (data) is transmitted over optical fiber by means of:
 - a) Light
 - b) Radio waves
 - c) Cosmic rays
 - d) Acoustic waves

6. Which is a modern-day application of fiber optic illumination?
 - a) Borescopes
 - b) Intersection "Walk" and "Wait" signs
 - c) Microscope specimen lighting
 - d) All of the above

7. What type of materials can be used as a lasing medium?
- a) Solid
 - b) Liquid
 - c) Gas
 - d) All of the above
8. The basic particle of light is:
- a) A photon
 - b) A quark
 - c) An electron
 - d) A neutron
 - e) A positron
9. Lasers are too dangerous to be used in fiber optics.
- a) True
 - b) False
10. Silicon is the most commonly used detector material in fiber optic applications for wavelengths between 400 and 1050 nm.
- a) True
 - b) False
11. List two advantages of using optical fiber.
- _____
- _____
12. Planck's Constant has been a tremendous benefit to the timber and wooden shipbuilding industries.
- a) True
 - b) False
13. The replacement of copper wiring harnesses with fiber optic cabling increases the weight of an aircraft.
- a) True
 - b) False
14. The "two personalities" of light can be represented either as electromagnetic waves or particles/photons.
- a) True
 - b) False

15. Light is a small part of the electromagnetic spectrum.
a) True
b) False
16. The shorter the wavelength of light, the higher its frequency.
a) True
b) False
17. One of the most important optical measurements of any optical material is its refractive index.
a) True
b) False
18. The speed of light in a vacuum is approximately 3×10^8 meter per second.
a) True
b) False
19. Circle the two most common materials of which optical fibers are made:
a) Plastic
b) Sodium chloride
c) Gallium aluminum phosphide
d) Glass
e) Flint
f) Hair
g) Diamond
20. The principle called total internal reflection explains why light cannot be guided in an optical fiber.
a) True
b) False

SAFETY

The Industrial Fiber Optics equipment that goes with this curriculum contains UL-certified power adapters and LEDs (light emitting diodes) that produce low-power incoherent radiation for maximum safety. The LEDs are broadband red 660 nanometer devices which can not be focused to a fine spot like a laser. Since some fiber optic equipment can contain lasers, please review our laser safety suggestions for future thought. Remember, just because you can not see the beam does not mean it is not dangerous.

RULES OF LASER SAFETY

- Lasers produce a very intense beam of light. Treat them with respect. Most educational lasers have an output of less than 3 milliwatts, and will not harm the skin.
- Never look into the laser aperture while the laser is turned on! **PERMANENT EYE DAMAGE COULD RESULT.**
- Never stare into the oncoming beam. Never use magnifiers (such as binoculars or telescopes) to look at the beam as it travels or when it strikes a surface.
- Never point a laser at anyone's eyes or face, no matter how far away they are.
- When using a laser in the classroom or laboratory, always use a beam stop, or project the beam to areas which people won't enter or pass through.
- Never leave a laser unattended while it is turned on—and always unplug it when it's not actually being used.
- Remove all shiny objects from the area in which you will be working. This includes rings, watches, metal bands, tools, and glass. Reflections from the beam can be nearly as intense as the beam itself.
- Never disassemble or try to adjust the laser's internal components. Electric shock could result.

LASER CLASSIFICATIONS

All manufacturers of lasers used in the United States, must conform to regulations administered by the Center for Devices and Radiological Health (CDRH), a branch of the U.S. Department of Health and Human Services.

The CDRH categorizes lasers into the following classes:

Class	Description
I	A laser or laser system which does not present a hazard to skin or eyes for any wavelength or exposure time. Exposure varies with wavelength. For ultraviolet light, (.2 to .4 μm), exposure is less than from .8 nW to .8 μW . Visible light exposure varies from .4 μW to 200 μW and for near-infrared light, the exposure is < 200 μW . Consult CDRH regulations for specific information.
II	Any visible laser with an output less than 1 mW of power. Warning label requirements: yellow caution label stating maximum output of 1 mW. Generally used as classroom lab lasers, supermarket scanners and laser pointers.
IIIa	Any visible laser with an output over 1 mW of power with a maximum output of 5 mW of power. Warning label requirements: red danger label stating maximum output of 5 mW. Also used as classroom lab lasers, in holography, laser pointers, leveling instruments, measuring devices and alignment equipment.
IIIb	Any laser with an output over 5 mW of power with a maximum output of 500 mW of power and all invisible lasers with an output up to 400 mW. Warning label requirements: red danger label stating maximum output. These lasers also require a key switch for operation and a 3.5-second delay when the laser is turned on. Used in many of the same applications as the Class IIIa when more power is required.
IV	Any laser with an output over 500 mW of power. Warning label requirements: red danger label stating maximum output. These lasers are primarily used in industrial applications such as tooling, machining, cutting and welding. Most medical laser applications also require these high-powered lasers.

PARTS LIST:

Industrial Fiber Optics' Fiber Optic Demonstration System contains the following components:

- 2 Lab Modules
- 2 120-VAC-to-12-VDC 500 mA power adapters with cords
- 2 1-meter 2.2 mm outside diameter, 1000 μm core optical fiber with ST connector on one end. (Sensor Fibers)
- 1 1-meter 2.2 mm outside diameter, 1000 μm core optical fiber with ST connector on both ends.
- 1 3-meter 2.2 mm outside diameter, 1000 μm core optical fiber with black jacket and ST connectors on both ends.
- 1 10-meter 2.2 mm outside diameter, 1000 μm core optical fiber with black jacket and ST connector on both ends.
- 1 1-meter 3.2 mm outside diameter, 62.5/125 μm glass core optical fiber with orange jacket and ST connectors on both ends.
- 1 3-meter 3.2 mm outside diameter, 62.5/125 μm glass core optical fiber with gray jacket and ST connectors on both ends.
- 1 3-meter 3.2 mm outside diameter, 62.5/125 μm glass core optical fiber with orange jacket and ST connectors on both ends.
- 1 10-meter 62.5/125 μm glass core duplex optical fiber with orange jacket and ST connectors on all 4 ends.
- 1 Infrared Detection Card
- 4 Orange banana-to-yellow banana plug 18 gauge wire test leads (with blue wire insulation)
- 2 Brown banana-to-brown banana plug 18 gauge wire test leads (with blue wire insulation)
- 1 Audio Interface 22 gauge wire test lead (black 3.5 mm male jack on one end, and a smaller black male jack and an orange banana plug on the other.)
- 1 Audio Interface 22 gauge wire test lead (with a black 3.5 mm male jack on one end, and a smaller black male jack and a brown banana plug on the other.)
- 1 Package of polishing film containing two pieces of 600-grit and 3 μm polishing film 10 \times 14 cm in size
- 2 Pieces of white paper 5 \times 10 cm (2 \times 4 inches) in size
- 2 Pieces of black paper 5 \times 10 cm (2 \times 4 inches) in size
- 2 Pieces of transparent plastic sheeting 5 \times 10 cm (2 \times 4 inches) in size
- 1 AM/FM radio with 3 AA batteries
- 1 *Laser Technology: Fiber Optics* (optional videotape)

EQUIPMENT FAMILIARIZATION

Lab Demonstration #1

The first Lab Demonstration in this course requires students to inventory and identify all items furnished with this fiber optic training module and required for the remaining eight Lab Demonstrations. This inventory process will introduce you to the nomenclature used in the manual and will speed completion of the following demonstrations.

Procedure

1. Choose a flat, level table approximately 90 × 120 cm (3 × 4 feet) in size as your work area for this demonstration.
2. At your work area, assemble all materials your instructor provides for you.
3. Identify each component in **Table 1**. Write in the column marked **ACTIVITY 1**, the number of components you found. If the number that you identify does not match the numbers in Column 2, notify your instructor.
4. Reference parts list on page 7 for further description of items if required.
5. Return all materials to their proper storage containers and locations.

#



Photo 1. With fiber optics being used more and more, some new home builders are installing fiber optics during construction.

Table 1. Inventory Sheet for Lab Demonstration 1.

DESCRIPTION	QUANTITY	ACTIVITY 1
Lab Modules	2	
120-VAC-to-12-VDC power adapters	2	
1-meter Sensor Fiber with ST Connector on one end	2	
1-meter 1000 μm core optical fiber with ST connectors on both ends	1	
3-meter 1000 μm core optical fiber with ST connectors on both ends	1	
10-meter 1000 μm core optical fiber with ST connectors on both ends	1	
1-meter glass optical fiber with orange jacket	1	
3-meter glass optical fiber with gray jacket	1	
3-meter glass optical fiber with orange jacket	1	
10-meter glass duplex fiber with orange jacket	1	
Orange banana-to-yellow banana wire test leads (with blue wire insulation)	4	
Brown banana-to-brown banana wire test leads (with blue wire insulation)	2	
Audio Interface wire test lead (with a black 3.5 mm male jack on one end, and a smaller black male jack and an orange banana plug on the other)	1	
Audio Interface wire test lead (with a black 3.5 mm male jack on one end, and a smaller black male jack and a brown banana plug on the other)	1	
White paper about 5 \times 10 cm (2 \times 4 inches) in size	2	
Black paper about 5 \times 10 cm (2 \times 4 inches) in size	2	
Transparent plastic sheeting about 5 \times 10 cm (2 \times 4 inches) in size	2	
AM/FM radio with 3 AA batteries	1	
Videotape (Optional)	1	

INTRODUCTION TO FIBER OPTICS

Reading Assignment #1

Only a few years ago fiber optics was little more than a laboratory curiosity. Physicists and other scientists in research labs were the only people doing much work in this field. Generally, it was considered an optical phenomenon with few practical applications in the real world.

Scientists and technicians pursued the technology purely for the sake of learning more about its scientific facts—not knowing that they would unlock a whole new world of practical and useful fiber optic devices. In the beginning, optical fibers were used only to illuminate hard-to-reach places such as the inside of a computer disk drive, or produce novelties such as "light trees" and multi-colored flashlights.

Today the applications are numerous, and more applications are being discovered almost daily. As only one example: In the medical field, using fiber optic probes, doctors can inspect the interior of our throat, esophagus and intestines. They can do the same inside human veins and arteries, to check for cholesterol blockage or disease. By combining fiber optics with lasers, doctors can clear blocked arteries without resorting to open heart surgery.

In most industries and professions, it is possible to transmit audio and video information over great distances and at very high speeds thanks to fiber optic technology. Data signals are carried by light waves and guided through flexible, hair-thin plastic or glass optical light pipes—more commonly known as fiber optic cable. You will learn how this is done and use these principles in the activities in this manual.

From seeing commercials on TV, you probably know that many long-distance telephone companies use fiber optics to link their main telephone distribution systems in the United States. More optical fiber is being added every day—underground, in buildings and on the same “telephone poles” that have supported copper wire telephone lines for almost a hundred years. Optical fibers are even being installed on electric power distribution poles because fiber optics is immune to electromagnetic interference (EMI) from the electrical wires.

The U.S. Armed Forces use optical fiber for portable battlefield communications, due to its reduced weight, smaller size and ability to avoid electronic eavesdropping. Other military applications include transmitting conversations between the cockpits of supersonic fighter aircraft and command stations on the ground or aboard Navy ships. Optical fiber is also used as a communication link to guide missiles to their targets. The same security advantages have led businesses to extensive use of fiber optics to transmit proprietary and financial data.

As fiber optic technology continues to advance, it will affect more and more parts of your everyday life:

- Custom and continually updating paperless, environmentally clean "newspapers" available for instant display on your home TV.
- High-definition TV will become reality—the lines you can now see so clearly on the TV screen will almost disappear.
- Accredited college classes on all kinds of subjects will be available in the comfort of your own home with two way communication.
- Internet access that will dwarf today's "high" modem speeds of 33 and 56 k will become common.
- New and dramatically improved medical procedures will emerge.

We have barely scratched the surface of fiber optics' potential to improve nearly every aspect of our existence. Now, in this manual, you will venture into the historical events that slowly but surely brought fiber optics into our lives.

#

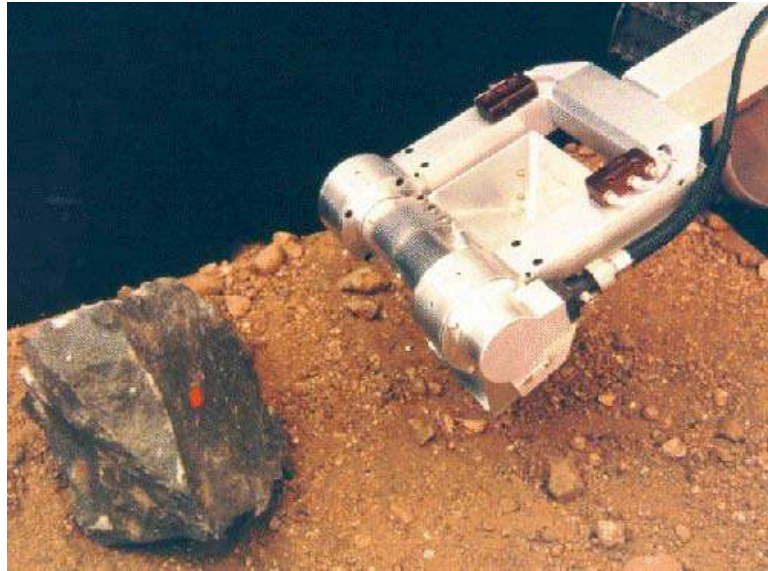

Photo 2. Optical fiber is used to transfer light on a lunar microrover arm to an internal optical analyzer.

Worksheet #1

Student: _____

1. The use of fiber optic materials does not decrease weight or size in aircraft.
 - a) True
 - b) False

2. List three applications of fiber optics:

3. Fiber optic cabling is being installed:
 - a) As replacement for copper telephone lines
 - b) Underground
 - c) In buildings
 - d) All of the above

4. Early optical systems were dependent upon:
 - a) Weather conditions
 - b) Line of sight
 - c) Time of day
 - d) All of the above

5. Light is a form of energy.
 - a) True
 - b) False
 - c) Sometimes
 - d) Rarely

6. Light, in the fiber optics vocabulary, means electromagnetic radiation or energy in the wavelength range including infrared, visible and ultraviolet.
 - a) True
 - b) False

7. Wavelength of light is:
- a) $= \frac{c}{f}$
 - b) $= \frac{f}{c}$
 - c) $= c \cdot f$
 - d) $= a \cdot b$
8. Total internal reflection is the fundamental principle that keeps light confined in an optical fiber.
- a) True
 - b) False
9. Circle the two materials that are used in optical fibers.
- a) Plastic
 - b) Uranium
 - c) Glass
 - d) Silicon
 - e) Carbon
10. The two most common light sources for fiber optics are:
- a) Lasers
 - b) Flares
 - c) LEDs
 - d) Incandescent bulbs

FIBER OPTICS AT THE BEGINNING

ACTIVITY #2:

You will begin your studies of fiber optics by delving into the history of light communications that led to modern-day fiber optics applications. You may find it interesting that optical communications started long ago. Its beginning was not in the 20th century as one might think. After learning about the history of optical communications, you will set up equipment that will allow you to transmit your own voice over optical fiber.

Equipment Needed:

- 2 Lab Modules
- 2 120-VAC-to-12-VDC power adapters with cords
- 1 10-meter duplex optical fiber
- 2 Orange banana-to-yellow banana wire test leads (with blue wire insulation)
- 2 Brown banana-to-brown banana wire test leads (with blue wire insulation)

To complete this activity you must:

1. Complete **Reading Assignment #2**.
2. Answer Questions 1 through 5 on **Worksheet #2**.
3. Complete **Lab Demonstration #2 - VOICE TRANSMISSION OVER OPTICAL FIBER**.
4. Complete **Homework Assignment #2**.

Homework Assignment #2:

Find and read one article in a newspaper or magazine about fiber optics. This article can be about any aspect of fiber optics including technology, application, or business. List the name of the article, its author and the publication in which it appeared. Good places to look include *Time*, *Newsweek*, daily papers, and science magazines. You may also look in the reference section of this manual for other suggestions.

WHEN DID FIBER OPTICS BEGIN?

Reading assignment #2

Light has been used as a form of communications for thousands of years. Undoubtedly, our prehistoric ancestors used the flickering light of campfires and torches to find their way in the darkness, and to signal each other.

Native Americans used smoke signals to extend the distances over which they could communicate with each other. Light also played an important role in the American Revolution. Lanterns displayed in the belfry of the Old North Church— "*One if by land, two if by sea...*"—sent Paul Revere on his famous ride, alerting citizens that British forces were attacking. Even today, lighthouses along rugged seacoasts relay their simple message warning sailors: "Danger! Stay away! Rocks or shallow water!"

These early optical systems worked well for transmitting very simple messages. Longer messages, either spoken or written, had to be conveyed person-to-person, or carried by animals, ships and wagons. The saddlebag mail delivery service performed by "Pony Express" riders in the 1800s was, for a brief period, the fastest form of communication in America. Still, the distance that could be traveled in one day was limited—usually by sore feet, tired horses and days at sea when no wind filled the sails of ships.

In the 1790s Claude Chappe built an optical telegraph stretching across France from Paris to Lille, a distance of 230 kilometers. The ingenious system used a series of signalmen, lights and movable arms in high towers to relay signals by day or night. A visual message transmitted from one tower would be read by the operator of the next tower, using a telescope. The second operator would arrange his own tower's signaling arms to relay the original message on to the next tower. And so on, through tower after tower. In this manner a message traveled from beginning to end in about 15 minutes.

Table 2. Standard units of measure.

UNIT	SYMBOL	MEASURE OF
meter	m	length
gram	g	mass
second	s	time
joule	J	energy
watt	W	power
hertz	Hz	frequency
ampere	A	current
degrees Kelvin	°K	temperature
degrees Celsius	°C	temperature
farad	f	capacitance
ohm	Ω	resistance

In the early years of the United States, Boston communicated with a nearby island using an optical telegraph. This method of communication eventually was replaced by the electric telegraph, which was faster, could operate even in poor weather conditions, and at any time of day.

However, optical data transmission technology was due to return—and when it did, the electric telegraph seemed primitive by comparison.

In 1870, before members of the British Royal Society, John Tyndall demonstrated light being guided in an arcing stream of water. (Today this phenomenon is called "light guiding by total internal reflection." See Figure 1.) About the same time, Alexander Graham Bell demonstrated the "Photophone." Although not practical, because it used sunlight as the optical source and thus didn't work at night, it demonstrated how light could be modulated to carry an audio (voice) signal to a remote location.

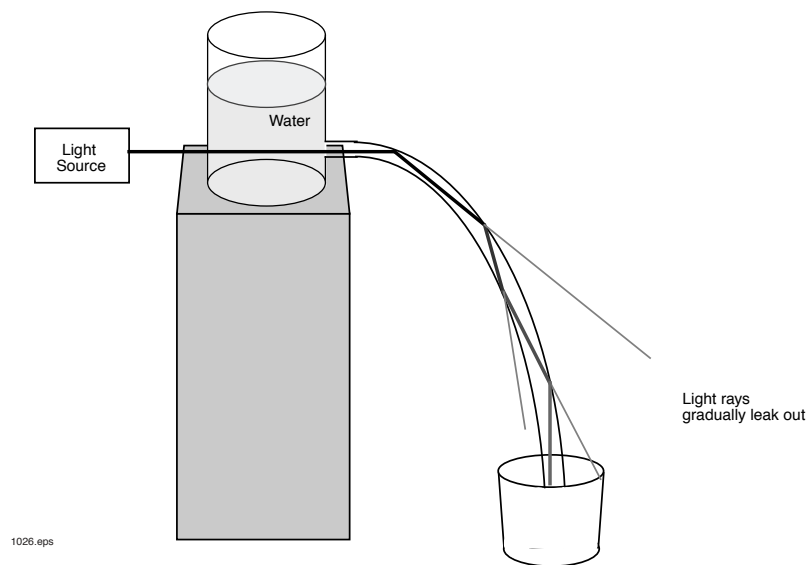

Figure 1. John Tyndall's experiment: Guiding light in a descending arc of water.

Fiber optic communications as we know it today originated in 1934 at American Telephone and Telegraph (AT&T) with research done by Norman R. French. He was granted a patent for an "optical telephone system" which carried voice signals on beams of light through a network of "light pipes." Although Mr. French didn't live to see it, his ideas were the beginning of today's fiber optic phone network.

During World War II the MASER (Microwave Amplification by the Stimulated Emission of Radiation) was developed. This concept was followed by the creation of the LASER in 1960 by Theodore H. Maiman of Hughes Research Laboratories in Malibu, California. Initially capitalized, LASER (abbreviation for Light Amplification by the Stimulated Emission of Radiation) is now a common word: laser. (It is ironic that the legal determination of patent rights to the LASER wasn't made until 1989, many years later.)

Prior to Maiman's success with the LASER, important work was being done in the 1950s on transistors and the beginning of modern-day semiconductor physics. (In other words, the scientific foundations were being laid for the Sony "Walkman®" and today's increasingly sophisticated video games.) These technologies grew and diversified into optoelectronics: electronics with optical properties. A critical development was the creation of the Light Emitting Diode (LED). Then came the development of the semiconductor laser diode in 1962.

During this time glass waveguides were emerging as the optical conduits for transmitting complex images through bundles of fibers. These are now known as "Fiberscopes," and are widely used in medicine. The term "Fiber Optics" was coined in 1956 with the invention of glass-coated rods.

In the 1960s, communication scientists working for telephone companies began to realize that they could combine small, compact LEDs and lasers with improved designs of glass fibers. (Little did they know that this concept would revolutionize the telecommunications industry.) In a 1966 research project at ITT, glass fiber was proposed as a transmission medium. Unfortunately, at the time, the most efficient light-carrying optical fiber had an attenuation (light loss rate) of 1000 decibels per kilometer (.1%/km) and therefore the transmission distance was very limited.

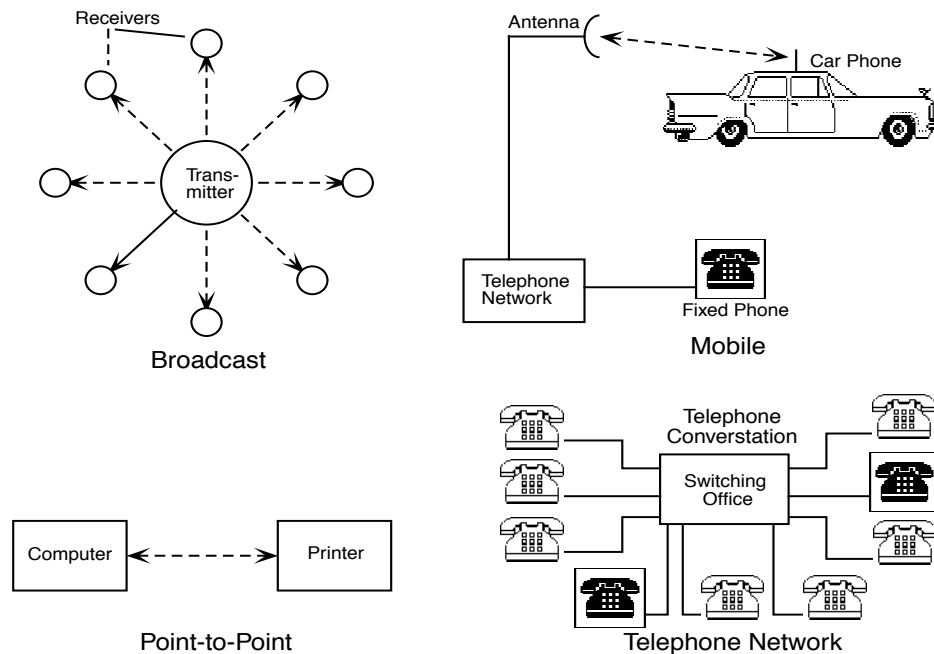

Figure 2. Types of communication systems.

Scientists turned their creative energies to improving optical fibers, and by 1972 Corning Glass Works had produced fiber with an attenuation of less than 4 dB/km. (This is equivalent to being able to see the bottom of the ocean through a half mile of water.)

In 1976, the Bell System installed a fiber optic telephone line at its Atlanta, Georgia, facility to see how well it could perform. Only one year later, the first field commercial trial of this technology occurred near Chicago. The system had outstanding performance, with an outage, or down-time rate, of 0.0001 percent at the end of one year. The Bell standard of performance was that down-time on the system couldn't exceed 0.02 percent. These early, very successful demonstrations led fiber optics to become the rapidly expanding field it is today.

Table 3. Metric prefixes and their meanings.

Prefix	Symbol	Multiple
tera	T	10^{12} (trillion)
giga	G	10^9 (billion)
mega	M	10^6 (million)
kilo	k	10^3 (thousand)
hecto	h	10^2 (hundred)
deca	da	10^1 (ten)
deci	d	10^{-1} (tenth)
centi	c	10^{-2} (hundredth)
milli	m	10^{-3} (thousandth)
micro	μ	10^{-6} (millionth)
nano	n	10^{-9} (billionth)
pico	p	10^{-12} (trillionth)
femto	f	10^{-15} (quadrillionth)

Most of the early work in fiber optics was done at optical wavelengths between 800-900 nanometers (nm) because that was the wavelength of the laser diodes and LED technology available at the time. By 1980, research confirmed that longer fiber optic communications systems using long wavelength designs were possible, but advantageous. This spurred the development of special-purpose, lower-loss fiber components which could operate in the 1300 nm and later the 1550 nm wavelength range. Today, continued research has brought us fiber systems capable of simultaneously carrying information on many different wavelengths.

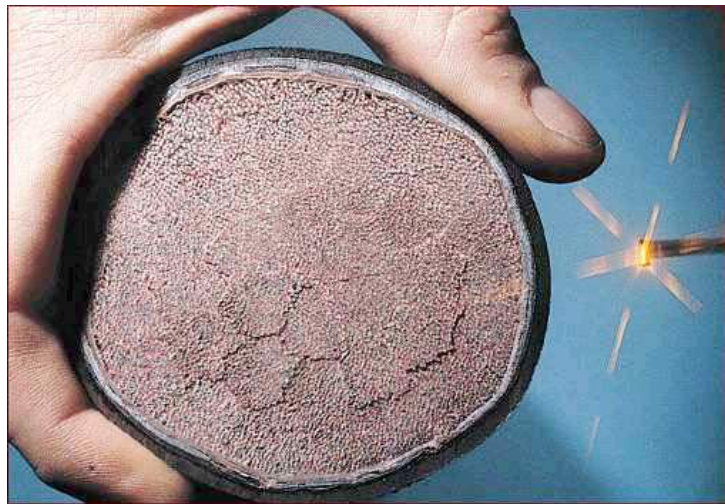

Photo 3. A single optical fiber can hold as much information as this large cable containing thousands of copper wires.

VOICE TRANSMISSION OVER OPTICAL FIBER

Lab Demonstration #2

This demonstration will show you how easy it is to make productive use of fiber optics. The equipment that you assemble will transmit voices from one location to another, using light traveling through an optical fiber. You'll learn that not only your own voice but other sounds can be carried over the optical fiber.

Procedure

1. Choose two flat, level locations approximately 60 × 90 cm (2 × 3 feet) in size, separated by 4 to 4.5 m (13 to 15 feet). (This demonstration is most dramatic if a door or other sound barrier is located between the two fiber optic communication units, to reduce the exchange of sounds produced in the two areas.)
2. Place the fiber cable and one of every other item from the Equipment Needed list at Location 1. Place all the remaining items at Location 2.

Location 1

3. Insert the yellow plug of the orange banana-to-yellow banana test lead into the yellow jack of the Audio Circuit on the Lab Module, and the orange plug of the same test lead into the orange jack of the Transmitter.
4. Insert either brown plug of the brown banana-to-brown banana test lead into the brown jack next to the speaker on the Lab Module. Insert the other end of the test lead into the brown banana jack in the Receiver section of the Lab Module that has the word "Analog" printed just below it.
5. Locate the fiber optic LED (FO LED) ST receptacle in the upper right portion of the Lab Module front panel. Insert an ST connector from the duplex optical fiber attached to the cable with the manufacturer's type number written on the jacket as follows: Align the key on the connector body with the slot on the ST receptacle, then gently push in. Rotate and push the knurled locking ring until the slots engage the bayonet ears on the ST receptacle. Continue twisting against the spring tension until the knurled ring snaps and locks over the bayonet ears."
6. Locate the fiber optic photodetector (FO DET) ST receptacle on the Lab Module front panel. Insert and lock the other fiber connector (attached to the unmarked cable) from the same end of the duplex cable as described in Step 5. (Taping the fiber cable to the table top will not hurt the fiber and makes your equipment setup neater).
7. Insert the small end of one 120-Volt Power Adapter cord in the black plastic jack located in the very left-center portion of the Lab Module (located just above and to the left of the Speaker).

8. Insert the two-pronged end of the Power Adapter into a 120-volt wall outlet or extension cord. The yellow LED labeled On (located just above the black power input jack) should light up. If not, make sure both ends of the Power Adapter are firmly plugged in.
9. Set the **Receiver Gain** knob to the 12 o'clock position.
10. String the 10-meter duplex fiber between the two locations.

Location 2

11. Identify the optical fiber at the unconnected end of the duplex optical fiber with the manufacturer's type number written on the jacket. (This is the cable installed into the fiber optic LED (FO LED) at Location 1.) Insert and lock the connector into the FO DET ST receptacle at Location 2.
12. Insert and lock the remaining fiber into the FO LED at Location 2.
13. Insert the yellow plug of the orange banana-to-yellow banana test lead into the yellow jack of the Audio Circuit on the Lab Module, and the orange plug of the same test lead into the orange jack of the Transmitter.
14. Insert either brown plug of the brown banana-to-yellow banana test lead into the brown jack next to the speaker on the Lab Module. Insert the other end of the test lead into the brown banana jack in the Receiver section of the Lab Module that has the word "Analog" printed just below it.
15. Set the Receiver Gain to the 12 o'clock position, just as you did at Location 1.
16. Insert the small end of the second 120-Volt Power Adapter cord into the black plastic power jack located in the very left-center portion of the Lab Module (located just above and to the left of the Speaker).
17. Insert the two-pronged end of the Power Adapter into a 120-volt wall outlet or extension cord. The yellow LED labeled On (located just above the black power input jack) should light up. If not, make sure both ends of the Power Adapter are firmly plugged in.
18. If a high-pitched squeal begins to sound from either speaker when you connect the power, reduce the internal amplification of both lab modules by turning their Receiver Gain knobs counter-clockwise until the noise subsides.

At each of your two locations you now have assembled an efficient communication unit which can operate as a "sender" and a "receiver" of acoustic (sound) waves. The Audio Circuit in your Lab Module converts sound waves into an electrical signal, which then is converted to an optical (light) form in the Transmitter circuitry. The optical signal is directed into the optical fiber, which carries it to the opposing Receiver. The Receiver's photodetector "decodes" the optical signal and converts light into an electrical signal which,

in turn, drives the Speaker on the Lab Module to create acoustic waves, or sound—in this case, the voices of the people in your class.

Your communication system is now ready for use. Position a person, or half your group, at Location 1 and the other half at Location 2.

19. Verify that each Lab Module is operating properly by lightly tapping or blowing across the **Microphone** located in the **Audio Circuit** of the Lab Module. If the sounds you hear are very faint, try increasing the volume by slowly turning the **Receiver Gain** clockwise.
20. Let each student talk through the system and hear students at the other location talking.

If you cannot adjust the Receiver Gain high enough to hear your voices before a high pitched squeal occurs try moving the modules further apart or, complete the following steps for the modules at both locations:

21. Unplug the AC Power Adapter plug where it connects to the Lab Module.
22. Remove the orange banana plug from the **Transmitter** jack and insert it into the orange jack of the **Momentary Switch**.
23. Take one of the additional orange banana-to-yellow banana test leads (with blue wire insulation) furnished with this system, and insert its yellow banana plug into the yellow jack left of the **Momentary Switch**. Then insert the other end (the orange banana plug) into the orange jack of the **Transmitter**.
24. Reinsert the AC Power Adapter plug into the power jack on the module. The yellow LED just above the power jack should light up. If not, check to make sure all of your connections are secure.

To transmit sounds from Location 1 to Location 2, you now must first depress the **Momentary Switch** at Location 1. To transmit sounds from Location 2 to Location 1, you must depress the **Momentary Switch** at Location 2. The Receiver Gain can now be increased without creating audio feedback problems.

25. Have one individual speak into the microphone while members of the other group try to figure out whose voice is coming through the fiber optic system.

Have one group of students create noises close to the microphone and ask the other group to identify the source of the noises. Some examples are crumpling paper, breathing, snapping your fingers briskly above the microphone, moving a finger across the surface of the microphone, plucking a rubber band, etc.

26. If possible, obtain some musical instruments and transmit their sounds across the fiber optic link.

27. Unplug both power adapters from the 120-volt outlet and the lab modules. Unlock ST connectors and roll up the 5-meter duplex fiber and return all items to their proper storage containers and locations.
28. Answer Questions 6 through 8 on **Worksheet #2**.

#

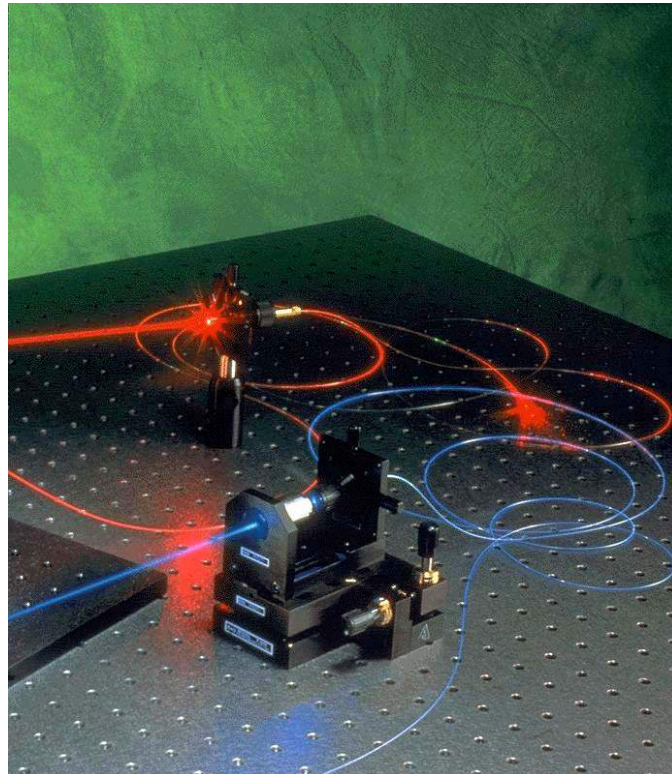

Photo 4. Red and blue laser beams being directed in two large diameter core optical fibers on an optical table.

Worksheet #2

Student: _____

- Optical communication dates back to:
 - 1060 B.C.
 - 1790 B.C.
 - 1790 A.D.
 - 1492 O.D.
- The optical telegraph replaced the electrical telegraph because it could operate at night.
 - True
 - False
- The invention of the _____ was one of the key elements making fiber optic communications possible today.
- When did the Bell System's first trial of a fiber optic communications network occur?
 - 1960s
 - 1070s
 - 1970s
 - 1990s
- Fiber optics can be used to transmit information very reliably.
 - True
 - False
- Did you find it hard to identify a person's voice at the other location in Lab **Demonstration #2**? If so, describe why.
- Do some sounds or voices transmit better than others? If so, identify them.
- Do any musical instrument tones not transmit through this fiber optic system? If so, describe why.

APPLICATIONS OF FIBER OPTICS

ACTIVITY #3:

Fiber optic communications, as observed in the previous activity, is a combination of three technologies: optics, lasers, and electronics. The three components of a fiber optic system—an optical fiber, transmitter and receiver—each incorporate at least one of each of these technologies.

- Optical fiber is understood through classical optical theory and manufactured by optical techniques.
- Transmitters and receivers are made of semiconductor materials, using semiconductor technology, so they apply electronics technology.
- The transmitters of most fiber optic systems use either light emitting diodes (LEDs) or semiconductor laser diodes. The semiconductor laser includes electronic and laser technology.

Equipment Needed:

- 2 Lab Modules
- 2 12-VAC-to-12-VDC power adapters with cords
- 2 3-meter optical fibers
- 4 Orange banana-to-yellow banana wire test leads (with blue wire insulation)
- 2 Brown banana-to-brown banana wire test leads (with blue wire insulation)

To complete this activity you must:

1. Complete **Reading Assignment #3**.
2. Answer Questions 1 through 10 on **Worksheet #3**.
3. Discuss your previous homework assignment with your lab partner or group. Review what the main topic of the article was and what you learned.
4. Complete **Lab Demonstration #3 - MORSE CODE DIGITAL TRANSMISSION**.
5. Complete **Homework Assignment #3**.

Homework Assignment #3:

Look for an application of fiber optics in your school or home activities. Write a paragraph on how the use of fiber optics in this application may offer improvements in function, reduced cost, smaller size, improved reliability, immunity to lightning strikes, etc.

FIBER OPTICS: WHAT IS IT USED FOR?

Reading Assignment #3

Fiber optics is best known for its uses in long-distance communications systems, but many other applications for fiber optics technology are being discovered almost daily.

In some cases, fiber optics may supplement existing technologies, and in other cases it may replace older technologies completely. Even more notable, however, is that fiber optics often can handle tasks which are not even feasible with other technologies. One example is an optical fiber installed in the spark plugs of internal combustion engines to view the combustion process. In this case, no other technology could have provided the means to effectively view inside a chamber where gas vapors are exploding. The possibility wasn't even considered until the capabilities of fiber optics were recognized.

Following are discussions of major applications of fiber optics. A list of all the individual applications would be very lengthy—and out of date—by the time it was published. Add to the list from your own reading, experience and imagination.

Communications

For the purposes of this discussion, we can define "communications" as selling the transfer of data, as a company's primary money-making product—for example, AT&T's long distance telephone service. Types of fiber optics communications networks include:

- **Long-Distance Telecommunications** – Land-based and undersea cable links are already in place, with more being installed and planned every year.
- **Short-Haul and Subscriber Telecommunications** – The networks of regional and local telephone companies which provide service to homes and businesses. High-capacity fiber optic networks are being installed in buildings, but are not yet being used extensively. Many new commercial buildings and some homes are having fiber cable installed during construction for future use. A delay in offering residential fiber optics systems is due in part to the high cost of the components. The entire utility network including TV cable, regional telephone, long distance service and electrical power is going through significant changes. Changes are the result of the federal government choosing to deregulate all of these industries and allowing competition to regulate prices, rather than the government itself or review by special state and local commissions. Changes include: Cable television companies now being able to offer Internet connections through their cable system, long-distance companies such as AT&T being allowed to compete in regional telephone markets, and regional telephone companies offering television products. Deregulation and market changes will not result in rapid deployment of fiber optics in this market segment in the next five years, if only because of the uncertainty of recovering the capital investment required for existing businesses and homes.

- **Video** – The segment of the communications industry which transmits images. In many areas of the United States, cable television companies, also known as CATV (Community Antenna TeleVision), also maintain and operate the physical components (fiber optic cable) which carry messages on the local telephone network. We say that video signals are very "bandwidth-intensive" —transmitting a video image requires roughly 50 times more capacity than is needed to transmit 1,000 words of audio. One fiber optic cable is capable of carrying both telephone services and cable TV services, with bandwidth to spare. With high-definition digital television standards being established and transmission beginning, this market segment is very open to change. Video data transmission may become obsolete within 25 years.
- **Computers and Local-Area Networks** – All of these networks demonstrate superior performance when implemented with fiber optics. The cost of fiber optic components has been too high for many applications, and copper-based systems have improved significantly in the last years—influences which have kept fiber optics from capturing more market share. Two factors are driving this market segment to a point where fiber optics may make significant inroads: the ever-increasing need for more bandwidth for networking and the fact that fiber optic components have been significantly reduced in cost and are much easier to use.

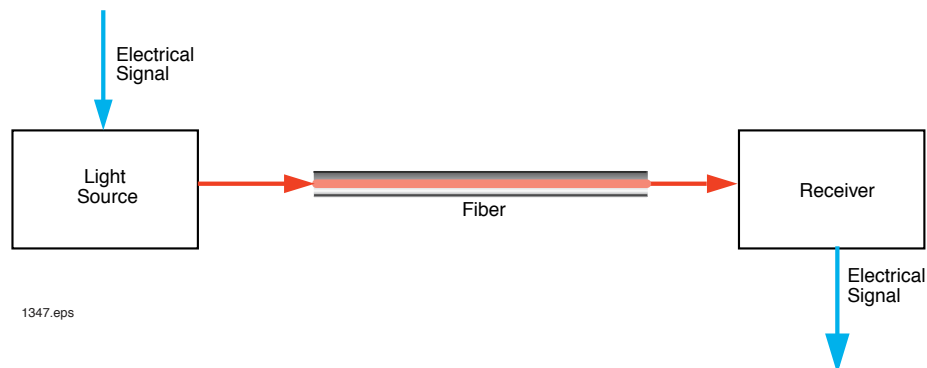

Figure 3. The three basic components of a fiber optic communication system.

Illumination

The earliest application of light coupling used for illumination was patented by William Wheeler in 1880. His concept used a single, central light source reflected to rooms in a house through a ductwork of light pipes to provide general purpose lighting.

This piping scheme was based on his idea that the incandescent bulb was impractical with no long-term potential.

Today, optical fibers are used in many illumination applications not readily lit by ordinary means. Examples include:

- Auxiliary lighting of microscope specimens.
- Illumination—inside the human body—for medical procedures
- Improved "vision" for automated machines which can scan products such as electronic components for defects or cosmetic imperfections.
- Borescopes used to examine the inside of rifle and pistol barrels.
- Sophisticated maps for use in mandatory low-light environments.
- Crosswalk "Walk" and "Wait" signs.
- Devices to monitor atmospheres which contain explosive fumes and gases.

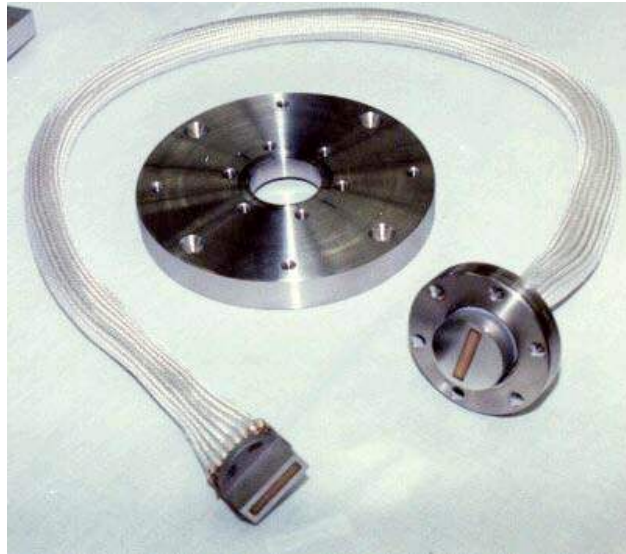

Photo 5. Optical fiber bundle enclosed in a flexible stainless steel sheath transfers light from one area to another.

Automotive

Communicating data in an automobile's many circuits presents many physical challenges as more and more sensors are designed into today's automobiles. A wiring harness may be subject to engine temperatures ranging from -40 to 150 degrees Centigrade, with prolonged exposure to petroleum-based solutions, road salts, sun and water. Fortunately, high-speed or long-distance communications are not required in the average car.

Plastic fiber is the leading candidate for automotive applications due to its easy alignment, simple termination procedure, and inexpensive connections. Affordable, heat-resistant plastic fiber (similar to the plastic fiber in this training system) has been tested, and product improvement is continuing.

Non-communications uses, however, have also been found and implemented in many of today's cars, such as:

- Dashboard lights
- Burned-out bulb indicators
- Ashtray and glove compartment lights
- Headlight high-beam indicators

A General Electric concept that may be seen in automobiles of the future is the "Light Engine." This design would replace all the car's lighting with an electric arc, using optical fiber to route the arc's light throughout the vehicle (the same concept as Wheeler's 1880 patent).

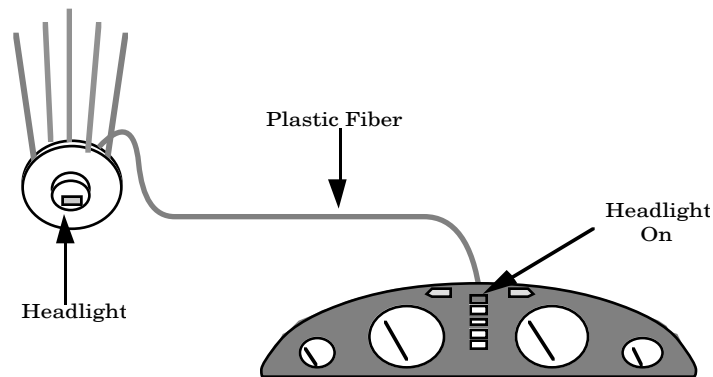

Figure 4. One of the uses for fiber optics in an automobile.

Aircraft

In 1976, the U.S. Air Force, as part of its Airborne Light Optical Fiber Technology (ALOFT) program, replaced the wiring harness of an A-7 jet aircraft with an optical link. The original wiring harness weighed 40 kg, was 1,260 meters long, and had 302 wires. The fiber optic replacement weighed 1.7 kg, extended 76 meters and contained only 12 fibers.

The operating conditions in an aircraft are similar to those in an automobile, but even more unfriendly to electrical and optical systems. Aircraft are subject to rapid changes in temperature, long duration at very high temperatures or very low temperatures, vibration, and bad weather. All aircraft hardware is specially made, then inspected by the Federal Aviation Association (FAA) before flight. The early success of the ALOFT and other military programs demonstrated the capabilities of fiber optics to withstand severe operating conditions while offering superior performance.

Optical fiber is used by the “Stealth Bomber” and MX Missile for many of their data transmission tasks. One study showed that if all the wire harnesses in a B-1 bomber were replaced by fiber optics, the plane's weight would be reduced by nearly 2,000 pounds. The weight savings could be used to increase fuel load and extend the range of the aircraft.

Security precludes knowing the full extent of fiber optics in the B-2 Stealth Bomber but it is expected to have made intensive use of this technology. The B-2's stealth technology replaced the airframe metals with composite structures, so copper wiring harnesses probably were replaced with fiber optics. Fiber optics systems also have a further advantage because they are unaffected by enemy electronic countermeasures or jamming attempts, and they don't radiate electronic signals which normally can be detected by very sensitive listening or tracking devices. Optical fiber located within an aircraft's wings and rudders can also continuously monitor stress and material fatigue during flight. Conventional sensors can't do this.



Photo 6. Fiber optics is used in large marine vessels to reduce size and weight.

Medical

Several medical applications have already been mentioned in previous sections, the most common being the endoscope. It is used for direct visual examination of arteries, heart, lungs, throat, and many other internal organs. Laser angioplasty uses a fiber optic bundle to transfer laser energy to burn away plaque in blocked arteries and restore blood circulation. Fibers are also used with lasers to fragment gall stones. These procedures replace conventional surgery, reduce trauma and allow quicker recovery time, all at lower risk.

Laser surgery is also common in less life-threatening surgery, such as arthroscopic surgery for damaged knee ligaments and cartilage. The key benefit of fiber-coupled surgery is the reduction in conventional cutting required to "repair" the ligament, thus less of the healthy surrounding tissue is damaged in surgery. (This is the type of surgery often associated with professional football and basketball injuries.) As these new procedures become more routine and cost-effective, the medical profession will begin to replace more conventional procedures with laser/fiber optic alternatives.

Sensors

Fiber optics can be used to detect external stimuli such as pressure, magnetic fields, temperature and rotation. These stimuli are measured by the characteristics of light transmission within an optical fiber. Sensors may be categorized by their principles of operation:

- *Fiber intensity sensors*, in which the intensity of a fiber's light transmission changes due to external stimuli.
- *Fiber optic probes*, where an optical fiber transfers light to a sensing tip as shown in Figure 5.
- *Remote optical sensors*, which are not the fibers themselves, but sensors that function from light received or transmitted through fibers.
- *Color sensors*, which detect changes in total energy or wavelength being transmitted.
- *Interferometric sensors* use two fibers and measure wavelength shift due to the length of time that light travels in one fiber compared to the time it takes light to travel in another fiber oriented in an equal and opposite manner.
- *Polarization sensors*, which detect externally induced changes in the polarization of light traveling through special polarization preserving fiber.

The applications listed herein for communications, illumination, aircraft, etc., are only a few when compared to the vast number of electronics applications. Optical technology is in its very early stages of development. It is very likely to have as great or greater an effect on the world than electronics. Pause a moment and let your imagination run free: Think of some potential uses for fiber optics that we haven't discussed yet.

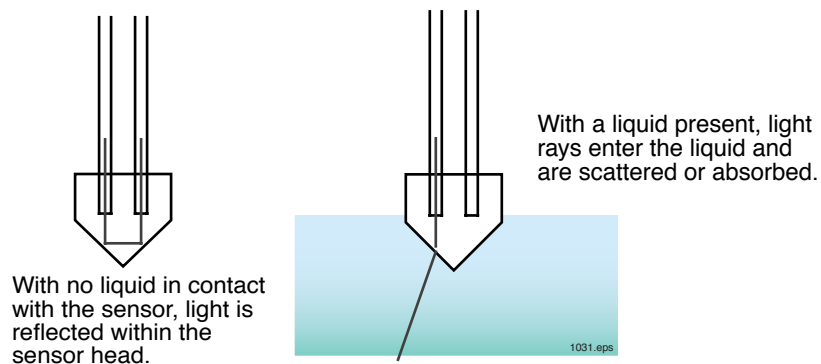

Figure 5. How a fiber optic sensor detects the presence of a liquid.

MORSE CODE DIGITAL TRANSMISSION

Lab Demonstration #3

In this demonstration we will convert letters and words to Morse Code and send them over a fiber optic link, much as the early electric telegraphs did. The Morse Code used here was the predecessor of modern age digital format which computers can "read." In the second part of the demonstration, you will see how computers "know" that data they transmit has been received.

Procedure A

1. Choose two flat, level locations approximately 60 × 90 cm (2 × 3 feet) in size, separated by approximately 2.5 meters (8 feet).
2. Place both fiber cables and half of the remaining items from the equipment list at Location 1. Place all the remaining items at Location 2.

Location 1

3. Insert the yellow banana plug of one yellow banana-to-orange banana test leads into the **Signal Generator's** Digital Output of the Lab Module which is the yellow jack located in the right-center of the front panel with the lettering "Output" just above it and the lettering "**Digital**" just below it. Insert the other end of the same lead into the **Momentary Switch's** orange jack.
4. Insert the yellow banana plug of the other yellow banana-to-orange banana lead into the yellow jack of the **Momentary Switch**. Then insert the orange banana plug of the same lead into the orange jack of the **Transmitter**.
5. Insert the brown plug of the brown banana-to-brown banana test lead into the brown jack next to the Speaker on the Lab Module. Insert the other end of the test lead into the brown banana jack in the **Receiver** section of the Lab Module that has the word "**Analog**" printed just below it.
6. Locate the fiber optic LED (**FO LED**) ST receptacle in the upper right portion of the Lab Module front panel. Insert an ST connector from the orange 3-meter optical fibers as follows: Align the key on the connector body with the slot on the ST receptacle, then gently push in. Rotate and push the knurled locking ring until the slots engage the bayonet ears on the ST receptacle. Continue twisting against the spring tension until the knurled ring snaps and locks over the bayonet ears.
7. Locate the fiber optic photodetector (**FO DET**) ST receptacle on the Lab Module front panel. Insert and lock an ST connector from the gray 3-meter optical fiber as described in Step 6. (Taping the fiber cables to the table top will not hurt the fiber and makes your equipment setup neater).

8. Set the **Signal Generator's** frequency switch at 3/4 of full scale (so the white mark is at about the "2 o'clock" position). Also, set the **Receiver Gain** knob at the 3/4 position.
9. Insert the small end of the 120-Volt Power Adapter cord in the black plastic jack located in the very left-center portion of the Lab Module (located just above and to the left of the Speaker).
10. Insert the two-pronged end of the Power Adapter into a 120-volt wall outlet or extension cord. The yellow LED labeled **On** (located just above the black power input jacks) should light up. If not, make sure both ends of the Power Adapter are firmly plugged in.

Location 2

11. Repeat Steps 3 through 5 on the second Lab Module.
12. Identify the orange 3-meter optic fiber originating from the **Transmitter** of Location 1 and insert it in the **FO DET** of Location 2's Receiver, following the same procedure as in Step 7 above.
13. Connect the remaining 3-meter fiber end (coming from Location 1's Receiver (FO DET)) to the **Transmitter (FO LED)** port of Location 2.
14. Repeat Step 8 on the second Lab Module.
15. Insert the small end of the 120-Volt Power Adapter cord in the black plastic jack located in the very left-center portion of the Lab Module (located just above and to the left of the Speaker).
16. Insert the two-pronged end of the second Power Adapter into a 120-volt wall outlet or extension cord. The yellow LED labeled **On** (located just above the black power input jack) should light up. If not, make sure both ends of the Power Adapter are firmly plugged in.

Now you should have two fiber optic communication units which can transmit an audio tone to each other when their respective **Momentary Switches** are pushed.

Depress the switch at each location. When Location 1's switch is pressed, the Speaker at Location 2 should sound. Likewise, the Speaker at Location 1 should sound when the switch at Location 2 is pressed. Adjust the volume (using the **Receiver Gain** knob) and frequency (using the **Frequency** knob) to suit the size of your room.

We will use the **Momentary Switch** to create the patterns used in Morse Code—a series of dashes and dots (long and short signals) used to represent individual letters of the alphabet, or numbers. "Operators" pause briefly between letters so listeners don't hear everything run together. Notice in **Table 4** that Morse Code contains no lower-case letters, punctuation, or other special symbols. Early telegraph messages were short and simple—no need for anything fancy.

Split your group into two parts, with half at each location. To start with, you will learn the code for the international distress signal: **S O S** which is three dots, three dashes and three dots.

S O S
 ... --- ...

Have each group at Locations 1 and 2 practice reading and transmitting the S O S signal. Create a dot by depressing the **Momentary Switch** for only a split second; hold the switch down slightly longer for a dash. Practice to make your dots and dashes consistent in length. The interval between letters is even longer than the time between dots and dashes within a letter. Practice transmitting the SOS signal until every student feels competent. (The yellow LED above the momentary switch will light up when the **Momentary Switch** is closed, which should help in creating dots and dashes uniformly.)

Each group will now write down the letters in some person's name, in expanded form as shown below. Don't tell the other group which name you've selected. It's also a good idea to start off with short names, of five letters or less; for example:

J A C K
 • --- • - - • - • - • -

Table 4. The Alphabet and Morse Code.

LETTER	SYMBOL
A	• -
B	- • • •
C	- • - •
D	- • •
E	•
F	• • - •
G	- - •
H	• • • •
I	• •
J	• - - -
K	- • -
L	• - • •
M	- -
N	- •
O	- - -
P	• - - •
Q	- - • -
R	• - •
S	• • •
T	-
U	• • -
V	• • • -
W	• - -
X	- • • -
Y	- • - -
Z	- - • •

In the spaces below, write the name which your group has selected. Beneath the letters, write the dots/dashes combinations which represent those letters, using **Table 4** for reference.

Name _____ _____ _____ _____

**Morse
Code**

Begin by having Location 1 transmit to Location 2. Select one person at Location 1 to "key" the selected name or word. At Location 2, designate one person to interpret the long and short signals being received, and another person to write down the dots and dashes.

When Location 1's transmission is complete, reverse the process, and have the group at Location 2 select and send a name for the Location 1 team to interpret.

Name _____ _____ _____ _____

**Morse
Code**

How well did your two groups do? If they correctly deciphered the other group's transmitted name, let them know. If not, have them try it again (without giving away the correct answer). Concentrate on keeping all the dots short and the dashes a little longer. Most important to sending an easily understood message is keeping the dots, dashes and pauses uniform.

When your two groups have successfully translated the first two names they picked, practice sending and receiving new names. Select alternate people to do the transmitting, interpreting, and writing at each location so everyone gets practice.

Morse Code obviously has some limitations, as you will have discovered by now. The accuracy of the translation depends on the skills of the transmitting and receiving operators. Nevertheless, the dots and dashes were an important communications tool spanning the wide open spaces of frontier America for many years.

Equally important: *The dots-and-dashes format served as the foundation for the digital communication theory widely used today.*

17. Answer Questions 11 through 14 on **Worksheet #3**.

Procedure B

In the previous procedure you sent messages over optical fiber using Morse Code. During the transmission of that message did you ever wonder if the other party definitely received your message? This question has been asked by others before you. One of the methods that has been developed to acknowledge information by the receiver is to send, or reflect, the same information back to the sender. This acknowledgment procedure is sometimes called "handshaking" in technical jargon. Following you will configure your equipment to demonstrate the "handshaking" protocol.

1. Remove the small end of the 120-Volt Power Adapter from the black plastic jack on the Lab Module at Location 2.
2. Remove both of the yellow banana-to-orange banana test leads from their respective banana jacks at Location 2.
3. Remove the banana plug of the brown banana-to-brown banana test lead that was inserted in the brown banana jack connected to the Speaker and insert it into the orange jack of the **Transmitter** at Location 2.
4. Insert the small end of one 120-Volt Power Adapter in the black plastic jack on the Lab Module (located just above and to the left of the Speaker) at Location 2.
5. Adjust Location 1's **Receiver Gain** knob to the 12 o'clock position and the **Receiver Gain** of Location 2 to the 2 o'clock position.

Now imagine yourself as the operator of some sophisticated processing system, and the equipment at Location 1 as a high-speed fiber optic link to a fellow scientist at another school. You are working together on this project, and you need to send him some critical information. Because this is important work, you want to make sure he received the information correctly. You and your brain now will process the information to compare the content of the transmitted information and returned information.

When the momentary switch is closed (that is, when you press the white button on the switch), you should hear an audible tone from the Speaker at Location 1. If not, double-check all of your assembly steps up to this point.

6. Press the **Momentary Switch** of Location 1. (The yellow LED above the **Momentary Switch** will light up when the switch is closed and the Lab module is transmitting a signal.) When you press the switch you should hear a sound from the Speaker at Location 1.
7. Adjust the **Receiver Gain** at Location 1 to a comfortable level not disruptive to other students in the classroom.
8. Answer Question 15 on **Worksheet #3**.

9. Vary the **Frequency** knob position of the **Signal Generator** on the Lab Module at Location 1 and press the **Momentary Switch**.
10. Answer Question 16 on **Worksheet #3**.
11. Change the **Signal Generator's Amplitude** by turning its knob at Location 1.
12. Answer Question 17 on **Worksheet #3**.
13. Remove the small end of the 120-Volt Power Adapter from the black plastic jack on the Lab Module at Location 2. Press the **Momentary Switch** on Location 1.
14. Answer Question 18 on **Worksheet #3**.
15. Reinsert the small end of the 120-Volt Power Adapter in the black plastic jack on the Lab Module at Location 2 and verify that sound comes from the speaker (at Location 1) when the **Momentary Switch** at Location 1 is pressed.
16. Uncinch the LED's ST connector at Location 2 and remove the optical fiber. Press the **Momentary Switch** at Location 1.
17. Answer Question 19 on **Worksheet #3**.
18. Insert the optical fiber back into Location 2's LED and lock the ST connector in place. Experiment further by disconnecting other optical fibers and test leads at either location.
19. Answer Question 20 on **Worksheet #3**.
20. Unplug both power adapters from the 120-volt outlet and the lab modules. Loosen the fiber optic cinch connectors and roll up the optical fibers and return all items to their proper storage containers and locations.

You have now seen how "handshaking" works for equipment. When there is a need to ensure that information transmitted from one point has been accurately received at another point. This is one small, but important, "inside look" at how networks, systems and networks function, and it is a procedure often used in many fiber optics applications today.

#

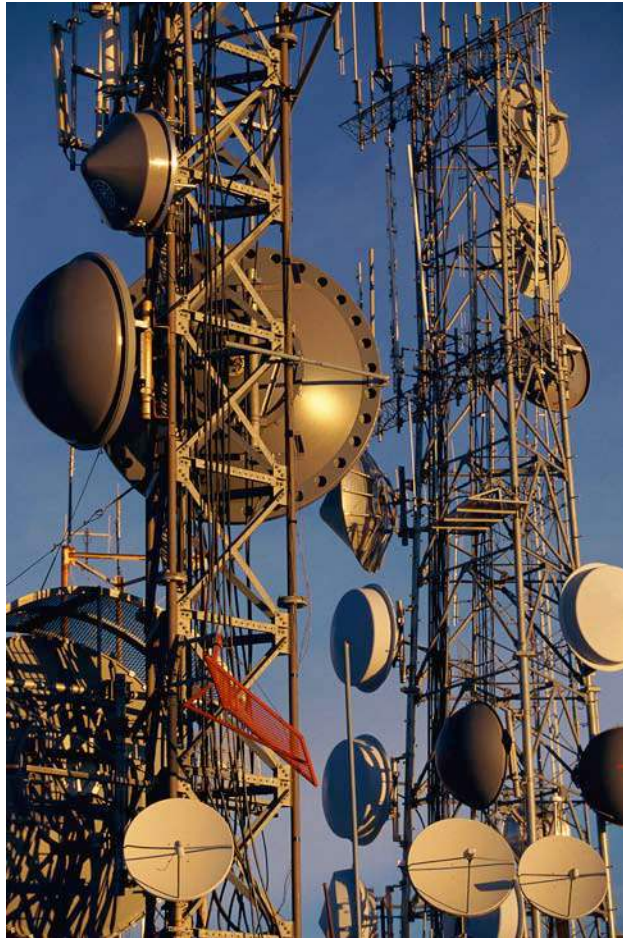

Photo 7. Fiber optics is often used to bring signals to and from communications relay towers because of its immunity to electrical noise.

Worksheet #3

Student: _____

1. Name at least three main areas of application for fiber optics.

2. Telecommunications networks do not use any fiber optics components.
 - a) True
 - a) False
3. The computer and local area network applications of fiber optics have been limited by the _____ of the fiber optic components.
4. Fiber optics has been used for _____ lighting in microscopes.
5. _____ optical fiber will most likely be used in automobiles of the future.
6. Automobiles demand very large temperature range capabilities for their optical cabling, ranging from - 40 degrees up to + _____ degrees Centigrade.
7. Replacement of copper wiring harnesses with fiber optics cabling decreases the weight of an aircraft.
 - a) True
 - b) False
8. Name one benefit to airplanes of installing fiber optics in them.
9. The use of fiber optics and/or lasers is not allowed in surgical procedures or hospitals.
 - a) True
 - b) False
10. Fiber optic _____ detect pressure, temperature, rotation and other physical characteristics.

11. Did you find it easy to master transmitting dots and dashes? Are your dots and dashes all uniform?

12. Did you find that everybody's dots and dashes were the same?

13. Is it clear when transmitting Morse Code when one word stops and another word starts?

14. Would you agree it is much easier for machines (for example, computers) to interpret dashes and dots and convert them to something more readily understood?

15. How long does it take after you press the **Momentary Switch** at Location 1 for a sound to be produced from the Speaker at Location 1?

16. When you vary the frequency on the **Signal Generator** at Location 1 how does the sound from the Speaker at Location 1 change? (Repeat Step 10 if necessary.) Explain your result.

17. How does the sound level from the Speaker at Location 1 change when you change the amplitude of the **Signal Generator**?

18. What happens to the sound from Location 1's Speaker when the **Momentary Switch** at Location 1 is closed and the power adapter at Location 2 is disconnected? Did Location 2 receive the signal? How can you tell?

19. Did you hear the reflected signal from Location 2 at Location 1's Speaker when its **Momentary Switch** was closed and the fiber was disconnected? Did Location 2 receive the signal? How can you tell?

20. Do you feel that this “handshaking”, or reflection, of transmitted data is a good method of ensuring correct data transmission? Why or why not?

LIGHT AT THE BEGINNING

ACTIVITY 4:

In **Activity 4** we will examine the basic physical characteristics of light, including its interesting behavior when it travels through and between different materials. In the Lab Demonstration we will show—using a radio—another way in which light energy can be used to convey sounds.

Equipment Needed:

- 2 Lab Modules
- 2 120-VAC-to-12-VDC power adapters with cords
- 1 3-meter 62.5/125 μm glass optical fiber
- 1 Audio interface wire test lead (with 3.5 mm male jack on one end, and a smaller black male jack and an orange banana plug on the other)
- 1 AM/FM radio with 3.5 mm earphone output jack
- 1 Audio interface wire test lead (with a black 3.5 mm male jack on one end, and a smaller black male jack and a brown banana plug on the other)
- 1 Brown banana-to-brown banana plug wire test lead

To complete this activity you must:

1. Discuss your previous homework assignment with your lab partner or group. Try to determine what benefit fiber optics offered in this application, compared to other technologies or methods.
2. Complete **Reading Assignment #4**.
3. Answer Questions 1 through 9 on **Worksheet #4**.
4. Conduct **Lab Demonstration #4 - AM/FM RADIO OPTICAL FIBER TRANSMISSION**.
5. Complete **Homework Assignment #4**.

Homework Assignment #4:

Think of a new application for fiber optics that has not been discussed in your reading material or this course. List the advantages and disadvantages (if any) of your invention.

LIGHT CHARACTERISTICS AND BEHAVIORS

Reading Assignment #4

Okay, it's time to get serious about this technical stuff! The introduction and application sections probably have convinced you that fiber optics does work. But, you may ask, how or why?

Fiber optics, as mentioned before as a technology and a field of study, consists basically of light sources such as transmitters, light-sensitive elements such as receivers, and optical light-pipes, or fibers, through which the transmitted light passes to reach the receiver. Although there are also other elements in a complete fiber optic system, such as power sources, connectors and housings, we'll discuss some of those support elements later. For now, we'll concentrate on helping you understand the technology of the optic fiber portion of any system.

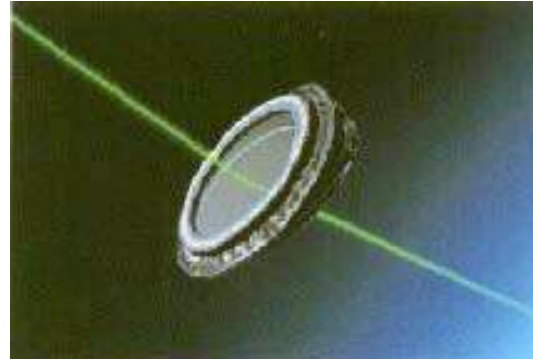

Photo 8. Laser beam redirected after passing through a glass wedge.

To begin with, we will start with an introduction or review of light, followed by how and why it is guided in an optical fiber. There will be a small amount of math involved to describe light's interaction with optical materials, but we will keep it brief.

Table 5. Common physical constants.

CONTANT	VALUE	SYMBOL
Speed of Light	3×10^8 m/s	c
Planck's constant	6.626×10^{-34} J-s	h
Electron charge	1.6×10^{-19} C	e
Boltzmann constant	1.38×10^{-23} J/°K	k
Electron rest mass	9.11×10^{-31} kg	m_e
Proton rest mass	1.6×10^{-27} kg	m_p
Neutron rest mass	1.67×10^{-27} kg	m_n

Light – Part of the Electromagnetic Spectrum

The workings of an optical fiber depend on the very basic principles of optics and the interaction of light with matter. The first step in understanding fiber optics is to review light. Webster provides two widely accepted definitions for light:

- (1) "something that makes vision possible," or
- (2) "the sensation aroused by stimulation of the visual receptors."

However, fiber optic transmission often involves the use of a third, more inclusive, definition that states:

"Light is electromagnetic radiation or energy in the wavelength range including infrared, visible, and ultraviolet."

From a physical standpoint, light can be represented with two "personalities": either as electromagnetic waves or photons. This is the important "wave-particle duality theory of modern physics." Here is a summary of that theory.

Many of light's properties can be explained by thinking of light as an electromagnetic wave. "Light" is a small part of the total electromagnetic spectrum, as shown in Figure 6. Light is higher in frequency and shorter in wavelength than the more common radio waves. Visible light's wavelength is from 380 nanometers (far deep violet in color) to 750 nanometers (far deep red). Infrared radiation has longer waves than visible light. Most fiber optic systems use infrared light between 800 and 1550 nanometers. This region is often referred to as the near-infrared (near-IR). Plastic fiber, which will be discussed later, operates best in the 650 nanometers (nm) area—the red, visible region.

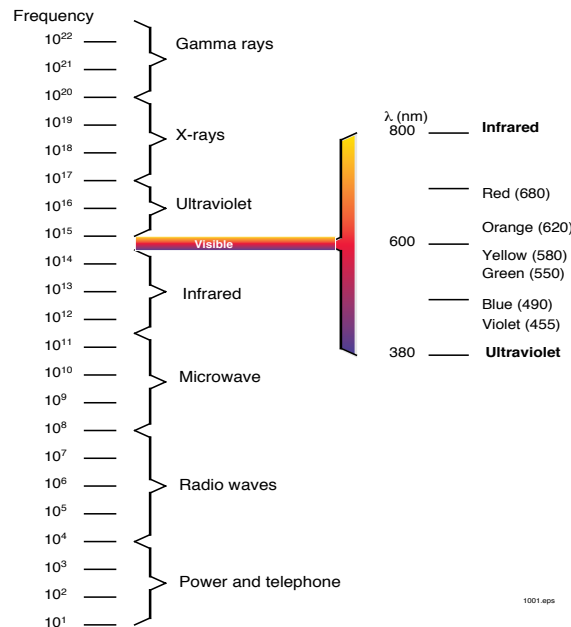

Figure 6. Light and infrared radiation within the electromagnetic spectrum.

Light is generally characterized by its wavelength. The shorter the wavelength, the higher the frequency. If you know one, you can determine the other. Mathematically that relationship is:

$$\lambda = \frac{c}{f},$$

where

λ is wavelength

c is speed of light in a vacuum

f is frequency

Light also exhibits some particle-like properties. A light particle is called a photon—an individual unit of energy. The energy contained in a photon depends on its frequency. The higher the frequency, the greater the energy. The energy (E) contained in a photon, measured in joules, is equal to the frequency (f), in Hertz, multiplied by a constant called Planck's constant. Mathematically, you would say:

$$E = h \times f$$

where h is Planck's constant (named after the man who determined it). The constant equals 6.63×10^{-34} .

Treating light as a wave or as a particle helps us when we study fiber optics. It is sometimes necessary to switch between the two descriptions of light to understand the different effects. For example, many properties of optical fiber vary with the wavelength, so the wave description is used. In the case of optical detectors, the responsivity of a photodetector to light is best explained with the particle theory. The wave theory of light can be traced back to the days of Galileo, but the particle theory came about only recently with the recent development of Einstein's Modern Physics theory.



Photo 9. Sunlight (white light) separated into its individual colors as demonstrated by a rainbow.

Index of Refraction

The most important optical measurement for any transparent material is its refractive index (n). The refractive index of any light-conductive medium is the ratio of the speed of light in a vacuum, to the speed of light in the medium. The speed of light in any material is *always* slower than in a vacuum, so all refractive indices are *greater than one*. In practice, a material's refractive index is measured by comparing the speed of light in it to the speed of light in air, rather than in a vacuum. This simplifies the measurements and does not make any practical difference, since the refractive index of air is very close to that of a vacuum.

$$n = \frac{\text{velocity in vacuum}}{\text{velocity in medium}}$$

Snell's Law

Light travels in straight lines through most optical materials. However, when light traveling within one medium encounters a boundary with another medium, something different happens. If the refractive index of the two materials differs, light is bent as it passes through the boundary—for example, passing from air into glass, as shown in Figure 7.

The amount of bending depends on the refractive indices of the two materials and the angle of the incident ray striking the boundary between the two mediums. The angles of incidence and transmission are measured from a line perpendicular to the

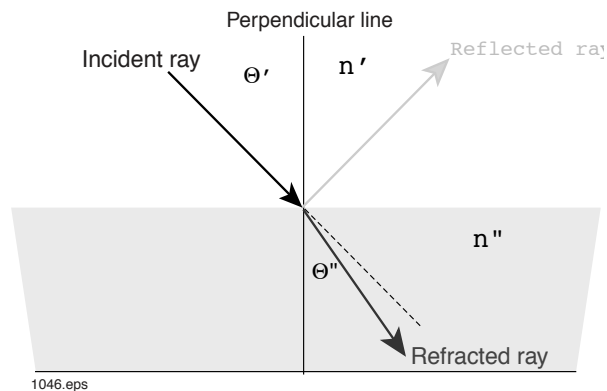

Figure 7. Bending of light rays at an optical boundary.

surface. The mathematical relationship between the incident rays and the transmitted rays was first predicted by a scientist named Willebrord Snell (1591-1626). Snell's Law describes the bending of light passing through a boundary between two optically conductive media, or materials. Mathematically, Snell's Law states:

$$n' \sin \theta' = n'' \sin \theta''$$

where n' and n'' are the refractive indices of the initial and secondary media, respectively, while θ' and θ'' are the angles of incidence and transmission, respectively.

Reflected Light

In some cases, light rays which strike the boundary between two media may be reflected back into the material from which they were trying to escape, rather than continuing on into the second medium. What makes the difference is the angle at which they strike the boundary.

It may not be obvious from Snell's Law, but this simple equation can be used to explain why light sometimes is reflected back into the medium it was trying to leave. Let's start with the assumption that material n' has a higher refractive index than n'' . (In Figure 7 n' is less than n'' .) Recall, also that the sine of the angles θ' or θ'' can never be greater than one. If the refractive index, n'/n'' and the product of sine θ'' is greater than one, an unrealizable solution to θ' exists. When this condition occurs, all the light is reflected back into n' . The angle at which this occurs is:

$$\theta' = \text{arc sin}\left(\frac{\sin \theta'' n''}{n'}\right)$$

Verbally describing the same situation: If light traveling through one material intercepts a boundary with another material having a lower refractive index, and if it strikes the boundary at a low enough, or "glancing" angle, it cannot get out of the first material. All the light is reflected back into the higher-index material through which it had already been traveling. This condition is called total internal reflection and explains how light is guided in an optical fiber. Further explanation and pictures of this phenomena will be continued in the next reading assignment.



Photo 10. Willebrord Snell is best known for the law of refraction, a basis of modern geometric optics which known only after his death.

Table 6. Refractive indices of some common materials.

MATERIAL	VALUE
Air	1.00029
Water	1.33
Glass	1.4 - 1.8
Silicon	3.5
Plastic	1.47 - 1.6
Diamond	2.0

AM/FM RADIO OPTICAL FIBER TRANSMISSION

Lab Demonstration #4

In this demonstration, the equipment you set up will allow you to observe/hear how the audio output from a radio signal travels through a fiber optic cable, using light, and the light waves at the other end are converted back into sound waves.

Location 1 in this activity is the transmitter, and will control ("modulate") the form of the light output from the **Transmitter LED** so it matches the form of the signal from an AM/FM radio. The optical fiber will collect the light from the LED and guide it down its core to the receiver at Location 2. Location 2 will convert the light which it receives from the optical fiber into an electronic signal and then amplify it. The amplified signal is then output to the speaker or to another piece of equipment, depending upon the procedure.

Procedure A in this activity electrically connects the equipment so the signal amplified at the receiver is output to the internal speaker of the Lab Module. Procedure B is optional, and contains the procedure to reconfigure Location 2 as an optical receiver location only and let another audio device convert the electrical signals into sound waves. This procedure requires an external audio device which is not included with this curriculum package.

Procedure A

1. Choose two flat, level locations approximately 60 × 90 cm (2 × 3 feet) in size, separated by approximately 2.5 meters (8 feet).
2. Set one each of the first five items listed from the **Equipment Needed** list at one location which we will call Location 1. Put the remaining items from the list at another location which we will call Location 2.

Location 1

3. Insert the smallest black male jack of the audio interface test lead vertically into the black horizontal tip jack connection located in the bottom right-hand corner of the Lab Module labeled **GND**.
4. Insert the orange banana plug located on the other wire of the audio test lead into the **Transmitter** orange banana jack.
5. Turn on your radio, tune to a static-free station and adjust volume to a comfortable listening level. Plug the 3.5 mm audio plug of the audio interface lead into the earphone jack of the radio or cassette player number.
6. Insert the small end of one 120-Volt Power Adapter cord in the black plastic jack located in the very left-center portion of the Lab Module (located just above and to the left of the **Speaker**).

7. Insert the two-pronged end of the Power Adapter into a 120-volt wall outlet or extension cord. The yellow LED labeled **On** (located just above the black power input jack) should light up. If not, make sure both ends of the Power Adapter are firmly plugged in.
8. Locate the fiber optic LED (**FO LED**) ST receptacle in the upper right portion of the Lab Module front panel. Insert an ST connector from the 3-meter optical fiber as follows: Align the key on the connector body with the slot on the ST receptacle, then gently push in. Rotate and push the knurled locking ring until the slots engage the bayonet ears on the ST receptacle. Continue twisting against the spring tension until the knurled ring snaps and locks over the bayonet ears.
9. Unroll the 3-meter fiber and string it between Location 1 and Location 2.

Location 2

10. Locate the fiber optic photodetector (**FO DET**) ST receptacle on the Lab Module front panel at location 2. Insert and lock the ST connector from the free end of the 3-meter optical fiber as described in Step 8.
11. Insert the banana plugs of the brown-brown test lead in the brown banana jacks of the **Receiver** and **Speaker**.
12. Adjust the **Receiver Gain** to approximately the 12 o'clock position.
13. Insert the small end of the second 120-Volt Power Adapter cord in the black plastic jack located in the very left-center portion of the Lab Module (located just above and to the left of the Speaker).
14. Insert the two-pronged end of the Power Adapter into a 120-volt wall outlet or extension cord. The yellow LED labeled **On** (located just above the black power input jack) should light up. If not, make sure both ends of the Power Adapter are firmly plugged in.

At this point you should be hearing sound from Location 2's speaker. This sound should be from the broadcasting station that you tuned the radio to at Location 1. If not, carefully go through the instructions again to see if everything is correct.

15. Adjust the **Receiver Gain** knob at Location 2 up and down and listen to changes in the sound produced by the Speaker.
16. Adjust the volume control of the radio at Location 1 up and down while listening for changes in audio volume.
17. Increase the volume control of the radio until the sound coming from the Speaker is no longer clear.
18. Answer Questions 10 through 12 on **Worksheet #4**.

Procedure B (Optional)

This procedure applies to those of you who wish to change the Lab Module located at Location 2 from using its internal speaker to one where the amplified electrical signal is electrically connected to an external speaker. (To complete the following procedure your audio equipment will need to have an input jack. This jack needs to be a 3.5 mm female port and will usually be found on the back or side panels of the equipment.) To re-configure, complete the following modifications to the equipment at Location 2.

1. Unplug the AC Power Adapter cord where it connects to the Lab Module.
2. Remove the brown banana-to-brown banana test lead from both jacks on the Lab Module.
3. Locate the other audio interface lead included with this trainer. It's identical to the first one except that it has a brown banana plug instead of an orange one at one end. Plug the brown banana plug of the audio interface lead into the brown banana jack with "**Analog**" printed just below it in the Receiver Section.
4. Insert the smallest black male jack of the audio interface lead vertically into the black horizontal tip jack connection located in the bottom right-hand corner of the Lab Module labeled **GND**.
5. Insert the black 3.5 mm audio plug of the interface test lead into the external (or "phono") jack of your external speaker or other audio device.
6. Reconnect the AC Power Adapter cord to Location 2. The yellow LED just above the power jack should light up. If not, check to make sure all of your connections are secure.
7. Set the **Receiver Gain** knob of Location 2 to the 12 o'clock position.
8. Turn your external speaker, or other audio equipment, on and adjust volume as required.
9. Experiment with the effects on the audio output of your equipment caused by changing the **Receiver Gain** setting.
10. Unplug both power adapters from the 120-volt outlet and the lab modules. Roll up the 3-meter optical fiber and return all items to their proper storage containers and locations.

#

Worksheet #4

Student: _____

1. Light, whose wavelengths include ultraviolet, visible and infrared, is part of the _____ spectrum.
2. The speed of light in a vacuum is approximately _____ meters per second.
3. Near-infrared radiation has a shorter wavelength than visible light.
 - a) True
 - b) False
4. The particle theory describes light as being composed of tiny packets of energy called:
 - a) Photons
 - b) Quarks
 - c) Electrons
 - d) Neutrons
 - e) Positrons
 - f) Bon Bons
 - g) a and c
 - h) b and c
5. When light passes from one material to another with a different refractive index, bending of the light occurs. Who first described this effect?

6. Planck's Constant helps ensure the precision of microscopic measurements in the timber and shipbuilding industries.
 - a) True
 - b) False
7. The principle which explains how light is guided in an optical fiber is called _____
8. A photon of infrared radiation has less energy than a photon from blue light.
 - a) True
 - b) False

9. The “two personalities of light” are _____
and _____ .
10. What happens to the sound from the Speaker as the receiver gain at Location 2 is changed?
11. What happens to the sound from the Speaker at Location 2 as the radio's volume is changed?
12. What might cause distortion in the fiber optic/electronic equipment that you have set up when the volume control is very high?

FIBER OPTICS IN OPTICAL SENSORS

ACTIVITY 5:

In this activity we will discuss basic structure of optical fibers and how they are able to transport light, even around corners. We'll conduct several demonstrations with fiber optic receivers and learn how fiber optics technology can be used in sensor applications.

Equipment Needed:

- 1 Lab Module
- 1 120-VAC-to-12-VDC power adapter with cord
- 1 25-foot electrical extension cord (not included in module)
- 1 Orange banana-to-yellow banana wire test lead (with blue wire insulation)
- 1 Brown banana-to-brown banana wire test lead (with blue wire insulation)
- 2 1-meter Sensor Fibers
- Light sources such as a fluorescent desk lamp, incandescent light bulb, television set, computer monitor, liquid crystal or LED display

To complete this activity you must:

1. Discuss your previous homework assignment with your lab partner or group. After group discussion, determine if the advantages of each person's "invention" outweighs its disadvantages.
2. Complete **Reading Assignment #5**.
3. Answer Questions 1 through 8 on **Worksheet #5**.
4. Conduct **Lab Demonstration #5 - FIBER IN ACTIVE & PASSIVE OPTICAL SENSORS**.
5. Complete **Homework Assignment #5**.

Homework Assignment #5:

Look in the Yellow Pages of a large metropolitan area phone book under "fiber optics." Select two companies whose advertisements suggest they make fiber optic products. Write down their names, phone numbers, and addresses.

LIGHT AND OPTICAL FIBER INTERACTION

Reading Assignment #5

The simplest fiber optic cable consists of two coaxial layers of transparent materials. A side sectional view of an optical fiber is shown in Figure 8. The inner portion, the core, carries the light. The outer layer is called the cladding. It surrounds the core and has a lower refractive index. The cladding, always having a lower refractive index than the core, traps light rays by total internal reflection within the fiber's core as discussed in the previous activity.

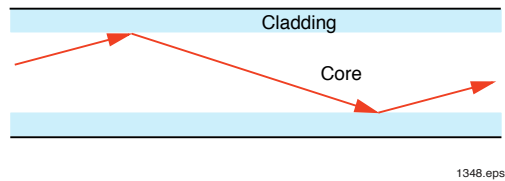

Figure 8. Light ray reflecting down an optical fiber.

Light ray(s) will travel through the core in a straight line until they strike the boundary between the core and its cladding. At that point the rays will glance off the boundary and continue in a straight line until they meet another boundary. In this manner, rays bounce their way within the core of the fiber, adjusting their path slightly, through reflection, as many times as needed to accommodate the gradual bends or curves in the fiber. When light rays reach the fiber end, having bounced off the walls of the core possibly thousands of times, they exit the fiber, giving the appearance of having traveled along a single curved path identical to that of the fiber and its core.

In Figure 9 the coaxial arrangement of the core, the cladding, and other elements of a generic commercial fiber cable are shown. As you can see by the figure, additional items besides cladding and the core make up a fiber optic cable. Not all cables contain every item. For example, marine (underwater) cables contain multiple fiber cores and cladding plus additional protective and strengthening layers not shown in Figure 9.

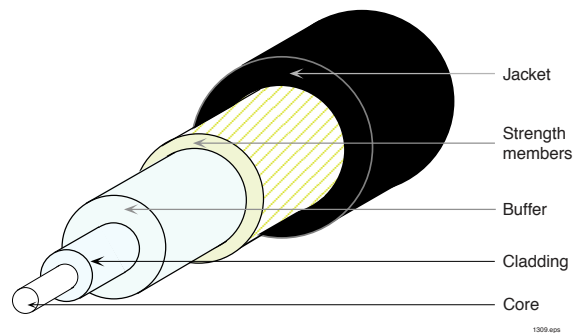

Figure 9. Cross-section of a typical optical cable.

Losses in Optical Fibers

Light transmission through an optical fiber is very efficient, but some light is lost. Light loss during transmission is called attenuation. The three most significant contributors to attenuation are:

- absorption by foreign materials within the fiber
- scattering of light out of the fiber core
- damage from heat, water and other external influences

Attenuation is also directly influenced by the wavelength of the light being transmitted and the composition or material of the fiber core and cladding.

The attenuation of an optical fiber is measured by comparing output power with input power. Fiber attenuation is usually specified in decibels (dB). The decibel is a logarithmic unit of measure for the ratio of output power to input power. All commercial optical fibers have a maximum specified attenuation of decibels per unit length, normally expressed in decibels per kilometer. The total attenuation in a fiber length, in decibels, equals the known fiber attenuation (dB/km) times the length of the fiber in kilometers.

Fiber Materials

The materials used in the construction of optical fibers are carefully chosen. The core and cladding must bond together well as to create a reflective type of surface, so light rays injected into the core travel within the core. Because the core and cladding always have different refractive indices, they are never exactly the same material.

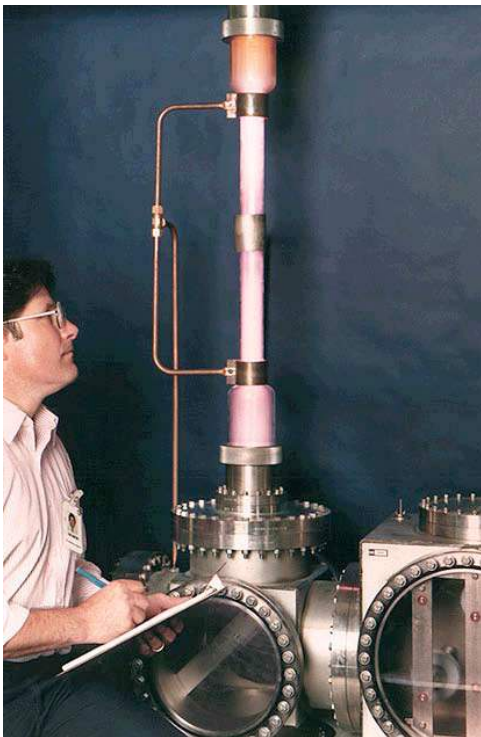

Photo 11. A continuous optical fiber coater in operation.

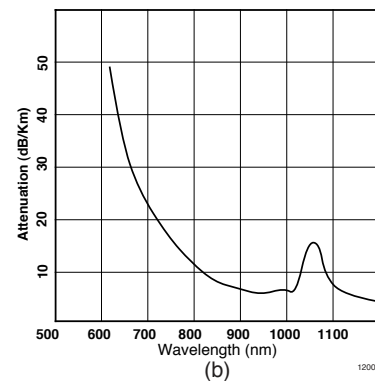
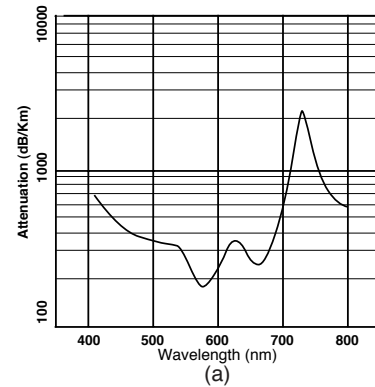

Figure 10. (a) Attenuation of plastic fiber. (b) Attenuation of glass fiber.

Two materials most often used in the fabrication of optical fibers are glass and plastic. Glass has superior optical qualities, but is generally more expensive than plastic. Glass fiber is used for high data rates and long-distance transmission. For lower data rates over short distances, plastic fiber is more economical due to its large core diameter, ease of termination and economical installation costs.

As we mentioned earlier, the attenuation of an optical fiber is very dependent upon the fiber core material being used and the wavelength of the light being transmitted. Attenuation curves of glass (a) and plastic (b) fibers are shown in Figure 10.

Observe that certain wavelengths have less attenuation, which results in better transmission properties than those of other wavelengths.

FIBER IN ACTIVE & PASSIVE OPTICAL SENSORS

Lab Demonstration #5

Many industrial and home applications use light or optical sensors for various purposes. Examples: security systems and lights that automatically go on when a room is dark. In this demonstration you will see how fiber optics can be used in various optical sensors.

In **Procedure A** of this demonstration we will use the light-gathering ability of optical fiber to construct a simple, remote passive optical detection sensor. Light which is collected by the fiber will be converted into an electrical signal by the photodetector and then amplified. This amplified signal will be converted to an audible signal by the Speaker on the Lab Module. We will output the amplified signals picked up by the passive sensor to the speaker for you to learn some things about light that our eyes are not capable of.

Procedure B will verify what your eyes and ears have seen in Procedure A.

Procedure A

1. Choose a flat, level location approximately 60 × 90 cm (2 × 3 feet) in size, on which to assemble this setup. The Lab Module will be moved around during this activity, so we suggest you use an electric extension cord to give you extra freedom of movement.
2. Insert the brown plug of the brown banana-to-brown banana test lead into the brown jack next to the speaker on the Lab Module. Insert the other end of the test lead into the brown banana jack in the **Receiver** section of the Lab Module that has the word "**Analog**" printed just below it.
3. Unroll both 1-meter Sensor Fibers. (ST connectors on one end only.)
4. Locate the fiber optic photodetector (**FO DET**) ST receptacle in the lower right portion of the Lab Module front panel. Insert the ST connector from a 1-meter Sensor Fiber as follows: Align the key on the connector body with the slot on the ST receptacle, then gently push in. Rotate and push the knurled locking ring until the slots engage the bayonet ears on the ST receptacle. Continue twisting against the spring tension until the knurled ring snaps and locks over the bayonet ears.
5. Turn the **Receiver Gain** knob fully clockwise to the **High** position.
6. Insert the small end of the 120-Volt Power Adapter cord in the black plastic jack located in the very left-center portion of the Lab Module (located just above and to the left of the **Speaker**).

7. Insert the two-pronged end of the Power Adapter into the female end of the 25-foot extension cord.
8. Insert the male end of the extension cord into a 120-VAC outlet. The yellow LED labeled **On** (located just above the black power input jack) should light up. If not, check all of your electrical 120-VAC connections.
9. Hold the free end of the optical fiber about 15 cm (6 inches) away from any operating fluorescent light. (You probably will need to move the Lab Module to complete this step.) The noise you hear coming from the Speaker is the sensor detecting the fluorescent light turning on and off at 120 times a second.
10. Move the fiber closer to the fluorescent light, and then away from it.
11. Answer Questions 9 and 10 on **Worksheet #5**.
12. Locate an incandescent lamp. Ensure that the lamp is on, then point the fiber tip directly at the bulb while holding it about 10 cm (4 inches) away from the bulb. Listen for the sound being produced by the Speaker on the lab module.
13. Answer Question 11 on **Worksheet #5**.
14. Obtain a television set and turn it on. Hold the optical fiber end as close as you can to the television screen. Move the fiber to different points on the screen while listening for differences in the Speaker's tone and volume.
15. Repeat Step 14 with a computer monitor screen that is on.
16. Answer Question 12 on **Worksheet #5**.
17. Move the Lab Module and fiber near a window, or outside, and point the fiber tip at the sun. Listen for the sounds produced by the Speaker.
18. Point the fiber tip at a piece of white paper illuminated by the sun.
19. Answer Question 13 on **Worksheet #5**.

Procedure B

Many LED and liquid crystal displays (LCDs) found in household and consumer electronics are turned on and off at a high rate, although they do not appear that way to our eyes. In the following steps you will see and hear, (1) that our eyes and brain can perceive only very low frequencies of light intensity; and, (2) high-frequency light pulses are "averaged" by our senses.

1. Insert one end of the orange-yellow test lead into the yellow jack of the **Momentary Switch**. Insert the other end into the yellow jack of the **Signal Generator** with the word "**Digital**" printed directly below it.
2. Turn the **Frequency** knob of the **Signal Generator** fully counterclockwise.
3. While observing the yellow LED located just above the momentary switch, turn the **Frequency** knob of the **Signal Generator** slowly clockwise. Observe how quickly your eyes do not discern the yellow LED turning on and off any more as you turn the knob.
4. Answer Question 14 on **Worksheet #5**.
5. When you have turned the **Frequency** knob clockwise to the point where you can not see the LED blinking any more, stop turning the knob.
6. Unplug the AC Power Adapter cord where it connects to the Lab Module.
7. Remove the brown banana-to-brown banana test lead from both jacks on the Lab Module.
8. Remove the banana plug that was inserted into the yellow jack next to the **Momentary Switch** and insert it into the brown banana jack to the immediate right of the Speaker.
9. Reconnect the AC Power Adapter cord to the Lab Module. The yellow LED just above the power jack should light up. If not, check to make sure all of your connections are secure.
10. You should now hear a very low-frequency sound from the speaker. Now slowly turn the **Frequency** knob counterclockwise.
11. Turn the Frequency knob slowly clockwise until you can no longer hear any noise coming from the Speaker or the knob will not turn any further.
12. Answer Question 15 on **Worksheet #5**.

#

Worksheet #5

Student: _____

1. _____ keeps light confined within the core of an optical fiber. (Supply three words.)
2. Light travels through an optical fiber's _____ and is restricted from leaving it by the lower refractive index of the _____.
3. Optical fibers are very low-loss guides for light rays.
 - a) True
 - b) False
4. Name the two most common materials from which optical fibers are made.

5. Light loss in an optical fiber is known as _____. It is usually measured in _____.
6. The following items can be found in fiber optic cables.
 - a) Core
 - b) Cladding
 - c) Jacket
 - d) Buffer
 - e) Strength members
 - f) All of the above
 - g) None of the above
7. Name one advantage and one disadvantage to using glass over plastic as an optical fiber.
 - a) Advantage:
 - b) Disadvantage:
8. What wavelength produces the lowest attenuation in plastic optical fiber?

9. What happens to the sound from the Speaker as you move the fiber closer to the fluorescent bulb. Why?

10. Were you surprised by the sounds from the Speaker when the optical fiber was pointed at the fluorescent bulb? Why?

11. Describe the sounds from the Speaker when the fiber was pointed at the incandescent light bulb.

12. Describe the amplitude and frequency of the sounds from the Speaker as you move the fiber tip to various points on the television screen. Compare the differences between the sounds you hear on the television and computer screens.

13. Describe the amplitude and frequency of the sounds from the Speaker as you use the fiber and Receiver to monitor the sun's light.

14. At what frequency would you estimate the LED to be blinking when you can just barely see it turning on and off?

15. Could you hear the output of the Signal Generator's digital output through the Speaker even though you could not see the LED blinking when appropriately connected? What does that tell you about the frequency response capability of our ears, compared to our eyes?

CREATION OF LIGHT FOR FIBER OPTICS

ACTIVITY # 6:

Activity #6 takes us further into the detailed study of fiber optic communication systems and to transmitters. We'll talk about the two major light sources used in fiber optic transmitters, and we'll go inside a transmitter to learn about the other support components as well. Our Lab Demonstration will show that the Lab Module transmits infrared light and how it can be used as an active optical sensor.

Equipment Needed:

- 1 Lab Module
- 1 120-VAC-to-12-VDC power adapter, with cord
- 1 Infrared Sensor Card
- 2 1-meter Sensor Fibers
- 1 Orange banana-to-yellow banana wire test lead
- 1 Brown banana-to-brown banana wire test lead
- 1 Piece of white paper about 5 × 10 cm (2 × 4 inches) in size
- 1 Piece of black paper about 5 × 10 cm (2 × 4 inches) in size
- 1 Piece of transparent plastic sheeting about 5 × 10 cm (2 × 4 inches) in size

To complete this activity you must:

1. Complete **Reading Assignment #6**.
2. Answer Questions 1 through 10 on **Worksheet #6**.
3. Discuss with your lab partner or group the information you found in the telephone book about a local fiber optics company. From the company name or ad, try to determine the product or service this company offers.
4. Complete **Lab Demonstration #6 - Attenuation in Optical Fiber**.
5. Complete **Homework Assignment #6**.

Homework Assignment #6:

Log onto the Internet and go to the web site <http://www.corning.com>. There you will find the web site for one of the leading optical fiber producers in the world. Explore their web site and prepare one paragraph on their products or technology to discuss in **Activity #7**. Using a search engine of your choice, (e.g., Yahoo, Lycos) find other web sites with fiber optic contents or products.

FIBER OPTIC TRANSMITTERS

Reading Assignment #6

Not all fiber optic transmitters are created equal. The components from which transmitters are made can vary considerably. Let's talk about the most essential ingredient—light sources—first.

Light Sources

Light emitting diodes (LEDs) and laser diodes are the two most common light sources used in fiber optic transmitters. Together they represent more than 99 percent of communication applications.

LEDs are used as light sources for short-to-medium distances, and short-to-medium frequency applications. Laser diodes are used as light sources for medium-to-long distances, and medium-to-high frequency applications.

LEDs (Light Emitting Diodes)

The LED, the simplest of the two sources, has the greatest usage because it is:

- Sturdy
- Long-lived
- Inexpensive
- Easily "driven" by electronic circuits
- Energy-efficient, requiring little power and voltage

The output light from LEDs is available in a variety of colors or wavelengths. The color emitted is entirely dependent upon the semiconductor material used. **Table 7** lists the most common LED and laser diode materials, with corresponding colors and their spectral output. Light produced by LEDs is loosely considered monochromatic, or consisting of one wavelength or color. In actuality, light energy from LEDs is distributed around a particular wavelength or color, and the output tapers off above and below the peak wavelength.

Table 7. Color and wavelength output from LED and laser diode semiconductor materials.

MATERIAL	COLOR	WAVELENGTH
Gallium phosphide	green	560 nm
Gallium arsenic phosphide	yellow-red	570-700 nm
Gallium aluminum arsenide	near-infrared	800-900 nm
Gallium arsenide	near-infrared	930 nm
Indium gallium arsenic phosphide	near-infrared	1300-1500 nm

A simple LED emits light randomly in all directions. Therefore, many LEDs used in fiber optics are constructed to optimize the light from a particular surface as shown in Figure 11. The LED shown has an etched well or hole which increases the amount of light emitted from the top surface. The etched well increases the amount of available light which can be collected by an optical fiber because it is closer to the light emitting region.

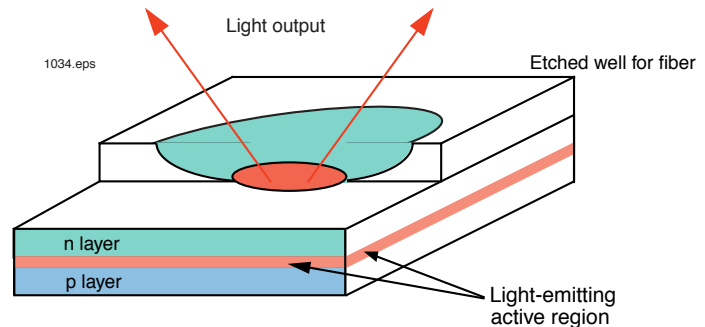

Figure 11. An exploded view of a light emitting diode.

When electrical current flows through an LED, electrons pass through the layers of semiconductor material and are absorbed in the depletion region of semiconductor material (see "Depletion region" in the Glossary). When an atom in the depletion zone absorbs an electron, one of its already orbiting electrons moves to a higher or "charged" state. In this "charged" state, the atom and orbiting electron are unstable and will eventually want to resume their normal or "rest" state. When the electron makes the transition from a "charged" state to the "rest" state the absorbed energy must be removed or emitted from the atom. This emitted energy is in the form of a massless particle called a photon. The process of photons (or light) being generated by electrons normally dropping from an upper charged state to the lower energy state, in random or natural manner, is called spontaneous emission of radiation.

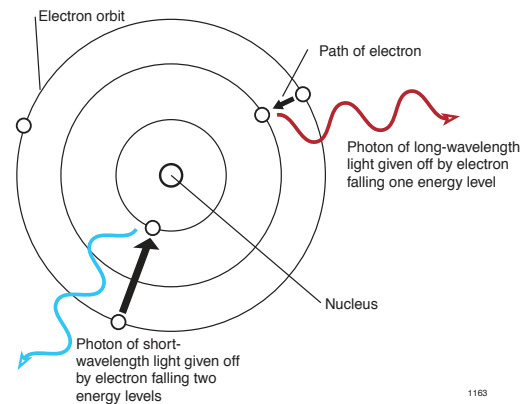

Figure 12. Atom with electrons falling from charged state to relaxed state.

All light produced by LEDs is non-coherent in nature. This means that the light rays, or photons, travel randomly in direction, phase and frequency, with respect to each other.

Laser Diodes

A laser diode's complete name is semiconductor laser diode. As is common in the English language, the "long version" has been shortened for convenience. Since there are no laser diodes other than semiconductor laser diodes, the shortening of the name causes no confusion.

Laser diodes have distinct advantages over LEDs. They have:

- Higher speed capabilities
- Narrower optical bandwidth
- Greater optical output power
- Better electrical-to-optical conversion efficiency

Laser diodes and LEDs are constructed of similar materials, as shown in **Table 7**. Furthermore, all laser diodes exhibit spontaneous emission of photons, just as LEDs do, at low electrical currents. As the level of electrical current being delivered to a laser diode increases, it crosses a level above which a phenomenon called "lasing" occurs. See Figure 13.

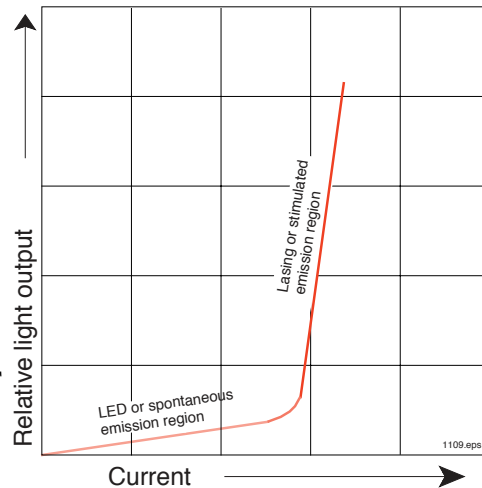

Figure 13. Relative light output versus input current of a laser diode.

For "lasing" or laser emission to occur inside a lasing device, special conditions must be met. First, the semiconductor material atoms must have more electrons in the higher energy "charged" state than in the lower "rest" state. The second condition necessary for lasing is that the photons created by spontaneous emission must be channeled or optically confined so they can stimulate other charged atoms to produce other photons. In a laser diode this optical channel is called a Fabry-Perot cavity. (Fabry-Perot are the last names of the two founding scientists.)

The Fabry-Perot cavity consists of two highly reflective mirrors at both ends of a channel (labeled "Active Region" in Figure 14), which in this case is inside the semiconductor material. This resonator optical guides the photons so they pass through the channel repeatedly, rebounding between the mirrors.

In describing the lasing process, we assume that current though the semiconductor material is flowing and there are more atoms with electrons in the "charged" state than the normal state. Now envision an atom with an electron in the upper charged state as a photon comes along and bumps or stimulates it. The charged electron is stimulated enough to resume its normal state. The electron falls back to its uncharged state and emits a photon. From there the process repeats, again and again.

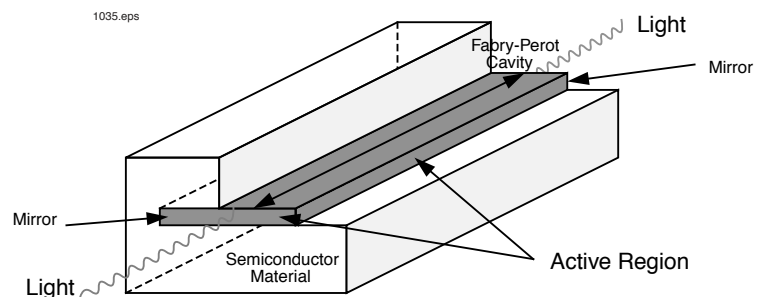

Figure 14. Internal components of a semiconductor laser diode.

The second photon is an exact "clone" of the first photon which stimulated its creation. This clone will be identical in frequency, direction and phase to the first. The

light produced by a laser (because all the photons are identical in frequency, direction and phase) is coherent. Lasers are the only known source of coherent radiation.

The amplification of the original photon is called stimulated emission. Lasers get their name from an abbreviation of their process—**Light Amplification by the Stimulated Emission of Radiation**. Lasing can occur only within very special material structures and atomic energy states.



Photo 12. An optical spectrum analyzer is used to characterize the light outputs from LEDs and lasers.

Other Transmitter Functions

The basic elements commonly found in fiber optic transmitters are listed below and shown in Figure 15.

- Housing
- Electronic interface
- Drive circuit
- Light source
- Optical interface
- Temperature sensor and control
- Optical monitor

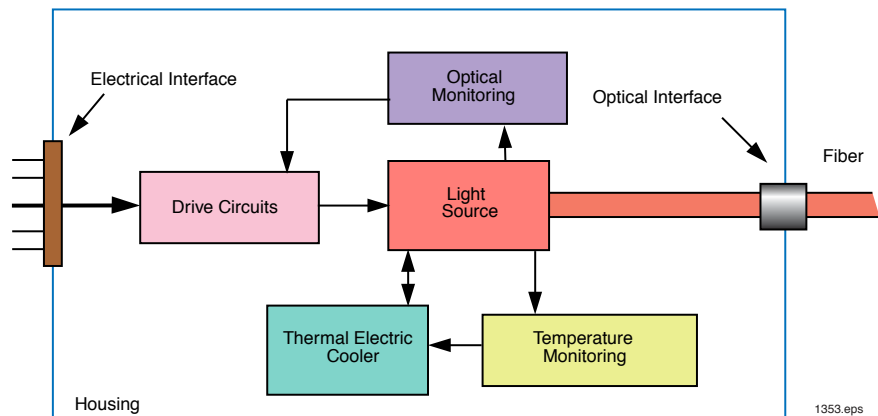

Figure 15. Elements commonly found in a fiber optic transmitter.

Design of fiber optic transmitters can become quite intricate. Following are descriptions of the remaining transmitter elements, to introduce you to their functions and operation. More specific transmitter details will be discussed in courses of advanced study.

Housing

The simplest housing for a fiber optic transmitter is an adequately sized box or container to which internal components such as electrical interface, drive circuits and fiber interface can be conveniently mounted by screws or other means.

Electronic Interface

Electronic interfaces can be wires, pins, or standard electrical connections. Transmitters containing an LED may have only two simple electrical connections. Others may be more complex, with 16 or more interconnections requiring several power supplies, grounds, control and functional indicators.

Drive Circuits

The type of electrical circuit in a fiber optic transmitter depends on the application for which the device will be used, the data format (such as analog or digital), and the light source inside. LEDs and lasers use similar types of driving circuits and are best driven by electrical current sources. (Most electronic signals are voltages, and therefore must be converted to current, which is the operational mode of LEDs and lasers.)

Optical Monitoring

Some transmitters include an optical monitor to control the light output of the source (that is, the intensity of the light produced by the transmitter). The monitor "samples" the energy leaving the transmitter and, depending on whether it is too high or too low, modifies the electrical current, through which in turn the light source increases or decreases the level of the light source. This "feedback loop" arrangement is most commonly found in transmitters which use lasers as the light source.

Optical Interface

There are two forms of optical interface:

- Fiber optic connectors (covered in more detail in **Activity #9**).
- Short optical fibers called *pigtails* which have a fiber end internally butted up to and aligned with the light source and brought outside the housing.

Figure 16 depicts four transmitters containing laser diodes which have fiber optic pigtailed as the optical interface. Devices such as these can have either a connector installed on the fiber end or be spliced to another fiber. (These samples are not included in this module.)

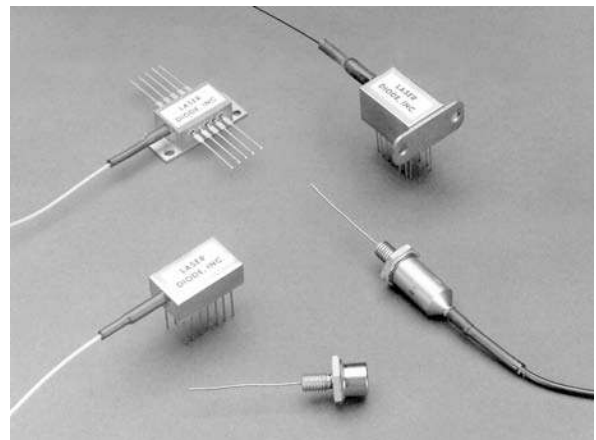

Figure 16. Four fiber optic transmitters with fiber optic pigtailed. (Courtesy of Laser Diode, Inc.)

ATTENUATION IN OPTICAL FIBER

Lab Demonstration #6

In this demonstration you will learn about a special material that will allow you to see infrared radiation/light not normally visible to the human eye. The transmitter in these lab modules creates near-infrared light which you will be able to see using a card with this special material on it. You will then create an “active” sensor (the word “active” means the sensor does not rely on ambient or an external light source) with this infrared light source and the receiver and fiber.

Procedure A

1. Choose a flat, level location approximately 60 × 120 cm (2 × 4 feet) in size, on which to conduct this experiment.
2. Insert the small end of the 120-VAC Power Adapter cord into the black plastic jack at the center left portion of the Lab Module (just above and to the left of the Speaker).
3. Insert the two-pronged end of the Power Adapter into a 120-volt wall outlet. The yellow LED labeled **On** (located just above the black power input jack) should light up. If not make sure both ends of the Power Adapter are firmly plugged in.
4. Locate the fiber optic LED (**FO LED**) ST receptacle on the Lab Module front panel. Look inside the receptacle and verify the presence of a dull red glow. You may need to dim the room lights to properly observe this. Answer Question 11 **Worksheet #6**.
5. Insert an ST connector from a 1-meter Sensor Fiber into the fiber optic LED (**FO LED**) as follows: Align the key on the connector body with the slot on the ST receptacle, then gently push in. Rotate and push the knurled locking ring until the slots engage the bayonet ears on the ST receptacle. Continue twisting against the spring tension until the knurled ring snaps and locks over the bayonet ears.
6. Look at the end of the Sensor Fiber and note the red glow as in step 4. Answer Question 12 on **Worksheet #6**.
7. Place the end of the Sensor Fiber close to the pale-yellow area on the Infrared Sensor Card. You should see a glowing area on the card corresponding to the infrared energy coming out of the Sensor Fiber. You may need to dim the room lights to see this. Change the distance between the fiber and sensor card and note how the size of the glowing area changes. Answer Question 13 on **Worksheet #6**.

Procedure B

In this portion of the activity you will re-configure the Lab Module to an active optical sensor. The Transmitter LED and connected fiber of your Lab Module will provide the light source for the sensor. Another fiber will collect the light originating from the LED and then carry this light down the fiber to the photodetector located in the Receiver circuitry of the Lab Module. This sensor will not depend upon ambient or external light to function.

The "performance indicator" for the sensor will be the Speaker. If the Speaker is relatively quiet, or if only a small amount of sound is coming from it, that means no light is entering the Receiver's optic fiber. (You will always hear a very small amount of sound coming from the Speaker. This is an intentional design feature, to indicate that the Lab Module unit is operating.)

In the following setups, the two fibers will be positioned to detect the presence of objects near the fiber ends.

1. Unplug the AC Power Adapter cord where it connects to the Lab Module.
2. Insert one end of the orange-yellow test lead into the yellow jack of the Signal Generator with the word "Digital" below it. Insert the other end into the orange Transmitter jack.

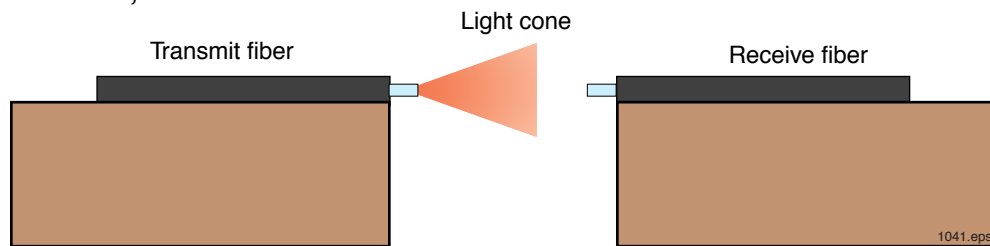

Figure 17. Side view of the Transmit optical fiber and Receive fiber pointed at each other for use in an active optical sensor.

3. Insert the banana plugs of the brown-to-brown test lead in the brown banana jacks of the Receiver and Speaker.
4. Locate the fiber optic detector (FO DET) ST receptacle on the Lab Module front panel. Insert and lock the ST connector from the unused 1-meter Sensor Fiber.

*In the following discussion we shall call the fiber connected to the LED the **Transmit** fiber and the fiber connected to the photodetector the **Receive** fiber.*

5. Turn the Signal Generator's frequency knob to the 3 o'clock position and the Receiver Gain knob fully clockwise to High.
6. Tape the free end of each optical fiber to the tops of two books of about the same thickness. Point the tips of the fibers at each another as shown in Figure 17, about 6 mm (.25 inches) apart.

7. Reconnect the AC Power Adapter cord to the Lab Module. The yellow LED just above the power jack should light up. If not, check to make sure all of your connections are secure.
8. Insert a piece of white paper midway between the fiber tips. Then move the paper about 2 mm away from the Transmit fiber.
9. Answer Question 14 on **Worksheet #6**.
10. Turn off the lights in the room, then slide the piece of white paper between the optical fiber tips again.
11. Turn on the room lights.
12. Answer Question 15 on **Worksheet #6**.
13. Pass a piece of cellophane or plastic between the tips of the two fibers and listen for changes in the sound level from the Speaker.

14. Pass a piece of black paper between the tips of the two fibers and listen for changes in the sound level from the Speaker.

15. Answer Questions 16 and 17 on **Worksheet #6**.

16. Rearrange the optical fibers side by side on a single book, angled slightly toward each other, as shown in Figure 18.

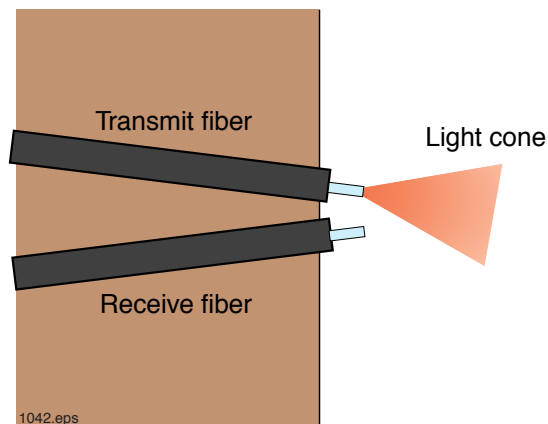

Figure 18. Top view of the Transmit and Receive fibers arranged in a reflective sensing configuration.

17. Hold a piece of white paper in front of the two optical fiber tips about 25 mm (1 inch) away. Move the paper closer and closer to the fiber tips until you locate the position at which the sound from the Speaker is at its maximum. (If you do not hear any sound for any position of the paper, position the fiber tips closer and at slightly different angles to each other.)
18. Estimate the distance from the ends of the fiber to the paper where the peak intensity occurs.
19. Move the paper closer to the fiber tips until the paper touches both ends.
20. Answer Question 18 on **Worksheet #6**.
21. Now pass the piece of plastic in front of the two fibers to determine if you can detect its presence.

22. Now pass the piece of black paper in front of the two fibers to determine if you can detect its presence. Try various distances from the fiber tips.
23. Answer Questions 19 and 20 on **Worksheet #6**.
24. Unplug both power adapters from the 120-volt outlet and the Lab Module. Roll up the 1-meter optical fibers and return all items to their proper storage containers and locations.

#



Photo 13. Engineer preparing to measure the attenuation through a spool of optical fiber. (Photo furnished by Newport Corporation.)

Worksheet #6

Student: _____

1. What two light sources are most often used in fiber optic systems?

2. LEDs are inexpensive.
 - a) True
 - b) False
3. LEDs can be made from the same semiconductor materials as laser diodes.
 - a) True
 - b) False
4. The wavelength (color) of optical output from LEDs depends on the kinds of materials used to make them.
 - a) True
 - b) False
5. What does the acronym "laser" stand for?
6. Name at least two advantages that lasers have over LEDs.

7. A laser is a source of coherent optical radiation.
 - a) True
 - b) False
8. Laser diodes and LEDs are driven by voltages, not currents.
 - a) True
 - b) False
9. Laser diodes are much simpler than LEDs.
 - a) True
 - b) False

10. Name at least two of the components inside a fiber optic transmitter.

_____	_____
_____	_____
_____	_____

11. The LED used in the Lab Module transmitter is an infrared type. Can you explain why a faint red light appears in the output?

12. Does the red glow at the end of the Sensor Fiber have more or less intensity than the **FO LED**? Why?

13. The IR Sensor Card makes infrared radiation visible by converting light from one wavelength or color to another. Give another example of this phenomenon in everyday life. (Hint: Think of something you may have seen related to light in a novelty shop.)

14. What happens to the sound from the Speaker when an object is placed between the Transmit and Receive fibers?

15. Does the existing light in the room—no matter whether the room lights are on or off—affect the sensing of an object moving between the two fibers?

16. Can you detect the presence of the plastic (from varying sounds from the Speaker) as you did with the white paper?

17. Can you detect the presence of the black paper (from varying sounds from the Speaker) as you did with the white paper?

18. Graph the intensity of the sounds from the Speaker as distance of the white paper from the fiber tips varies.

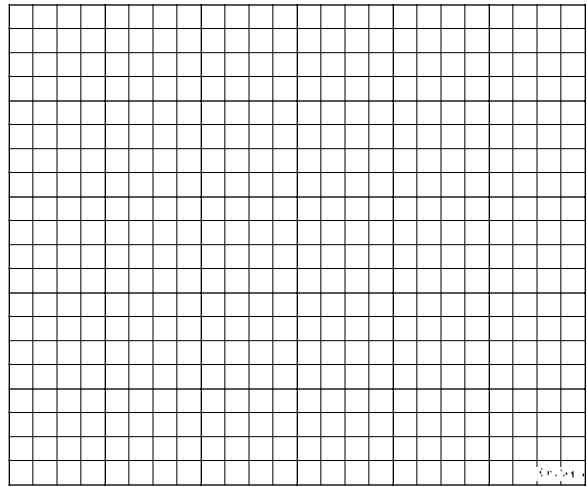

19. Could this sensor be used in a manufacturing company? (Hint: Perhaps for counting objects which pass a point on an assembly line.) How?

20. How is this sensor configuration in Figure 17 different than the one in Figure 18? Is it the opposite—that is, does the volume increase when objects are present?

FIBER OPTIC RECEIVERS

ACTIVITY # 7:

In previous activities we reviewed the properties of light and discussed fiber optic applications, optical fiber and fiber transmitters. In this activity you will read about the “end” piece of a fiber optic link—the receiver. You will learn about the individual components that make up a receiver as well as different types of photodetectors. Our lab demonstration will demonstrate how light energy can be lost in an optical fiber.

Equipment Needed:

- 1 Lab Module
- 1 120-VAC-to-12-VDC power adapter, with cord
- 1 1-meter glass optical fiber
- 1 3-meter glass optical fiber
- 1 10-meter glass duplex optical fiber
- 1 1-meter 1000 μm core optical fiber with black jacket
- 1 3-meter 1000 μm core optical fiber with black jacket
- 1 10-meter 1000 μm core optical fiber with black jacket
- 1 Orange banana-to-yellow banana wire test lead
- 1 Brown banana-to-brown banana wire test lead

To complete this activity you must:

1. Complete **Reading Assignment #7**.
2. Answer Questions 1 through 10 on **Worksheet #7**.
3. Discuss with your partner or group the results of your investigation into Corning’s web site and what you found using search engines in **Homework Assignment #6**.
4. Complete **Lab Demonstration #7 - Termination and Bending Losses**.
5. Complete **Homework Assignment #7**.

Homework Assignment #7

Log onto the Internet and go to web site <http://www.patents.ibm/>. Once at the site, conduct a search for patents covering fiber optics or optical fibers. Find two patents that interest you and write a paragraph about each on its merits or benefits. Be prepared to discuss in your next activity.

RECEIVERS FOR FIBER OPTIC SYSTEMS

Reading Assignment #7

The fiber optic receiver of a communication system is a decoder. It converts optical light which contains coded information into a usable (voltage) output. The basic elements of all fiber optic receivers are shown in Figure 19. The most critical elements of a fiber optic receiver are the photodetector and the preamplifier.

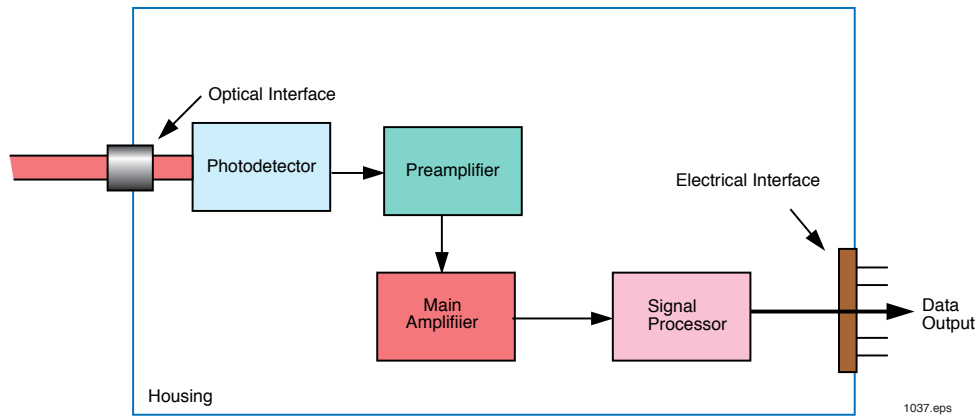

Figure 19. The common components in a fiber optic receiver.

Photodetector Basics

The photodetector performs a function opposite that of the light source in the **Transmitter**—it converts optical energy to electrical current. Where fiber optics is used for data communications, semiconductor technology produces the most suitable photodetectors—as is the case with light sources. Semiconductor photodetectors are:

- fast
- low-cost
- easily interfaced with electronic circuits

A list of the most common fiber optic photodetector materials is shown in **Table 8**. As can be seen by comparing **Tables 7** and **8**, some photodetector materials are also used to make LEDs and lasers.

Table 8. Photodetector materials and their detecting regions.

MATERIAL	WAVELENGTH (nm)
Silicon	400 - 1050
Germanium	600 - 1600
Gallium arsenide	800 - 1000
Indium gallium arsenide	1000 - 1700
Indium arsenic phosphide	1100 - 1600

Photodetector Types

There are four basic semiconductor photodetector types:

- Photodiode
- Avalanche Photodiode
- Phototransistor
- Photodarlington

All of these photodetectors produce an electrical current in response to light. Light rays or photons absorbed by the photodetector material dislodge electrons from the semiconductor atoms. These freed electrons then produce current flow if a bias voltage has been applied as shown in Figure 20.

Each of the four photodetector types has advantages and disadvantages. Some have high speed, and some have high gain. In nearly all cases they require additional processing and conditioning electronics.

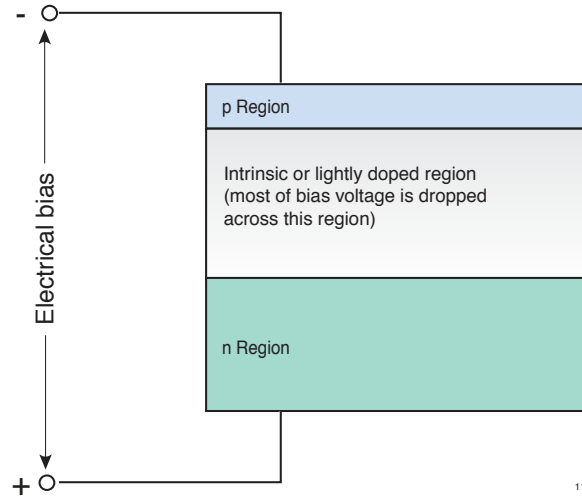

Figure 20. Photodiode structure with applied electrical bias.

Photodiode

Photodiodes are the most common and useful detector type in fiber optics. They have a simple, easy-to-fabricate structure easily implemented in any semiconductor material. Their other advantages include very fast rise and fall times, reasonable price, excellent linearity, high reliability and only low-voltage bias requirements.

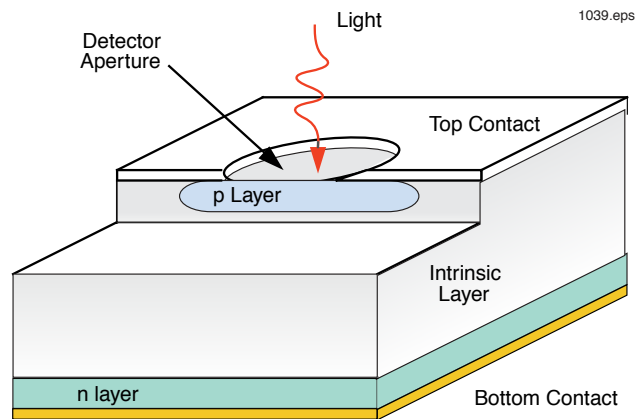

Figure 21. Cross-section of a photodiode.

A cutaway diagram of a photodiode is shown in Figure 21. Observe how the optical field of view is defined by the hole in the top contact. The photodiode produces electrical current by absorbing light that passes through the detector aperture. In a photodiode a single photon can create no more than one electron and hole.

Avalanche Photodiode (APD)

The avalanche photodiode is like a specially designed photodiode and is the second most commonly used detector in fiber optic telecommunications systems. It has some analogies to the laser diode. In a laser, a few primary photons cause many emitted photons. In an avalanche photodiode, a few photons produce many electrons and holes.

The APD operates like the photodiode in a reverse-biased mode, only with much higher bias voltage (typically 100 to 400 volts). This bias voltage creates a much stronger internal electric field in the intrinsic layer.

Like a photodiode, in the avalanche photodetector sensing of light photons begins first in the intrinsic region, when a light photon is absorbed, creating an electron and hole pair. This strong electric field causes the electron and hole to accelerate away from each other. As these electrons and holes accelerate due to the strong electric field and gain energy, they collide with stationary atoms and dislodge other electrons and holes, generating more sets of electrons and holes. This process of increasing the number of electrons and holes is called avalanching. The avalanche process amplifies the number of carriers generated from a single photon from 10 to 100. A graph of multiplication versus applied bias voltage is shown in Figure 22.

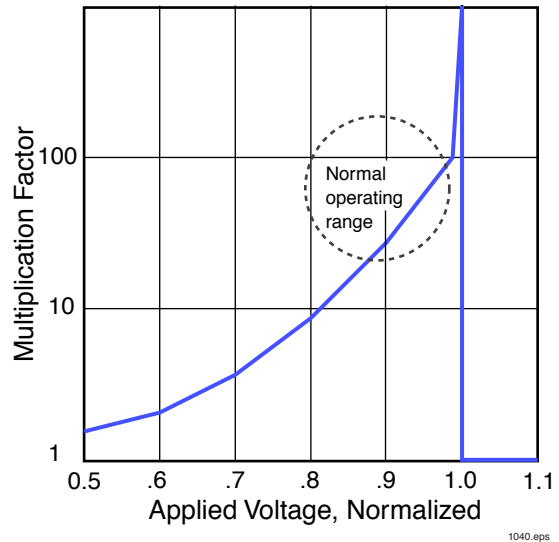

Figure 22. The increase in an APD's current multiplication versus applied voltage.

An avalanche photodiode amplifies the optical/electrical signal before the signal enters the preamplifier. This is good for many fiber optic systems because its maximum operating length may be limited by the preamplifier's internally generated noise. (See Figure 19.) By increasing the signal before the preamplifier, the fiber length can be made longer or the transmitter light source can be less powerful. Avalanche photodiodes are most often used in fiber optic systems to lengthen their operating distance and in systems where the greatest sensitivity is required. APDs do have some disadvantages when compared to regular photodiodes, however:

- Gain variation with temperature
- High voltage and more complex bias voltage circuitry required
- Greater power dissipation
- Higher price
- Lower production yield and volume

(If you haven't previously learned enough from other sources to fully understand this discussion of semiconductor materials, layering, electron/hole pairs, and so forth, don't worry about it. You don't have to know that much to understand fiber optics, but it helps if you do.)

Phototransistor

The responsivity of a phototransistor is much higher than that of a photodiode, typically from 100 to 500 mA/mW with rise and fall times of approximately 10 μ s. Phototransistors are inexpensive and easy to make. Their disadvantages include marginal linearity, gain variations versus temperature, and the fact they are suitable for only low-frequency applications. Phototransistors are most often used in industrial applications utilizing plastic optical fiber under 200 meters in length and frequencies less than 150 kHz.

The structure of a phototransistor is similar to that of a regular npn transistor except that, instead of the base area being covered with a metal conductor or opaque insulator, it has a transparent or open area through which light or photons can pass. These photons pass through the open area, are absorbed in the base and create the equivalent of a base current in a regular transistor. This base current flows to the emitter and causes a collector current like a regular transistor. Amplification of the base current is typically 50 to 500. This amplification is why the responsivity or the current produced for optical input is much higher for a transistor than a photodiode.

Photodarlington

A photodarlington is a phototransistor with the addition of another transistor, all in the same semiconductor die. An electrical diagram of the photodarlington is shown in Figure 23.

The responsivity of a photodarlington is approximately 10 times higher than that of a phototransistor. Typical values for a silicon photodarlington may range from 500 to 2000 mA/mW. This increase in responsivity comes at a price, which is a decrease in rise and fall times. Photodarlington, as compared to phototransistors, are more expensive, have even poorer linearity, more gain variations versus temperature, and are suitable for only low-frequency applications. The photodarlington is used mostly in digital industrial



Photo 14. Technician examining a semiconductor wafer which could contain LED, laser, or photodetector die.

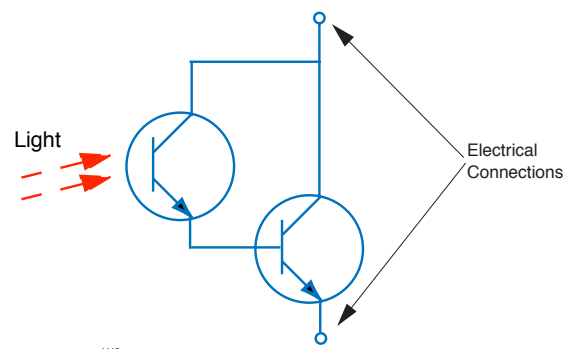

Figure 23. An electrical schematic of a photodarlington.

applications utilizing plastic optical fiber where the maximum operating distance is needed, a very simple receiver design is beneficial and for frequencies less than 100 kHz.

Preamplifier

The preamplifier establishes the two most important performance levels in most fiber optic systems:

- Minimum detectable optical signal
- Electrical bandwidth

At the input to the preamplifier, the received signal (which is a very small current) is the most susceptible to extraneous noise sources. It's the easiest point at which noise can enter the fiber optic system and cause interference. The signal is at its weakest point here, and any interference entering this node will be amplified, along with the signal, from this point on. Typical input-current level to a preamplifier ranges from 0.1 - 100 μ Amp.

Preamplifiers convert current from the photodetector to an output voltage. This transimpedance function—volts per amp—is how they get their other name: transimpedance amplifiers. The words preamplifier and transimpedance amplifier are often used interchangeably when describing components in fiber optics receivers.

A circuit diagram of a common operational amplifier configured as a transimpedance amplifier with a photodiode detector is shown in Figure 24. This circuit is very similar to the receiver circuit used in the lab module for this curriculum. When light strikes the photodiode, current flows from positive to negative, and a negative voltage swing from the LM741 amplifier results.

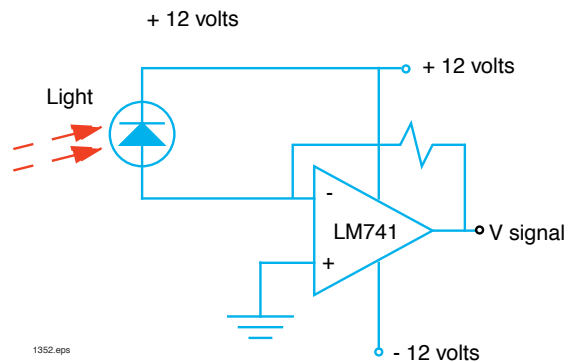

Figure 24. An electrical schematic of a fiber optic photodetector and preamplifier.

Main Amplifier

The purpose of the main amplifier in a fiber receiver is to further amplify the signal from the preamplifier. The photodetector and preamplifier are not significantly different in analog and digital receivers, but the same is not true for the main amplifier and signal processor. Typical output voltages from the main amplifier would be 0.7 to 3.4 volts in a digital TTL system. (TTL is a family of electronics parts whose electrical signal levels have become a digital standard and are used in many computer interconnections.) In an analog system, the main amplifier could be a device for driving a 1-volt peak-to-peak video signal into a 50- or 75-ohm standard communications load.

Signal Processor

In an analog system, the processor simply strips the modulation, or information, off the amplified signal and converts it to a known output level. In a digital system, however, the output from the main amplifier must be processed by a shaping filter to restore the signal to precise pulse shapes.

Housing, Electronic Interface and Optical Interface

A fiber optic receiver's housing, electronic interface and optical interface are nearly identical to those of transmitters. See the preceding section on transmitters for more information about these items.



Photo 15. Researcher sets up equipment to test or characterize a fiber optic transmitter.

TERMINATION AND BENDING LOSSES

Lab Demonstration #7

In general, fiber optic cables lose less energy with distance than traditional copper wiring. In this demonstration you will discover how loss in fiber optic cables depends on the materials from which the fiber is constructed. You will use the lab module as an instrument to measure attenuation in fiber optic cables.

Procedure A

1. Choose a flat, level location approximately 60 × 120 cm (2 × 4 feet) in size, on which to conduct this experiment.
2. Insert one end of the orange-yellow test lead into the yellow jack of the Signal Generator with the word "Analog" below it. Insert the other end into the orange Transmitter jack.
3. Insert the small end of the 120-VAC Power Adapter cord into the black plastic jack at the center left portion of the Lab Module (just above and to the left of the Speaker).
4. Insert the two-pronged end of the Power Adapter into a 120-volt wall outlet. The yellow LED labeled On (located just above the black power input jack) should light up. If not make sure both ends of the Power Adapter are firmly plugged in.
5. Unroll the 1-meter glass fiber optic cable and lay it in a large arc.
6. Insert an ST connector from the 1-meter glass fiber optic cable into the fiber optic LED (FO LED) as follows: Align the key on the connector body with the slot on the ST receptacle, then gently push in. Rotate and push the knurled locking ring until the slots engage the bayonet ears on the ST receptacle. Continue twisting against the spring tension until the knurled ring snaps and locks over the bayonet ears.
7. Insert and lock the other end of the 1-meter glass fiber optic cable into the fiber optic photodetector (FO DET).
8. Turn the Signal Generator Frequency knob clockwise to the 3 o'clock position. Turn the Signal Generator Amplitude knob counter-clockwise completely to minimum scale (lowest amplitude).
9. Adjust the Receiver Gain knob until the green LED just begins to light. This adjustment is sensitive, so perform it several times until the knob position is consistent. Record the position of the knob in **Table 9**, in degrees of rotation (assume 0 degrees is straight up).
10. Repeat steps 5 through 9 for the 3-meter glass optical fiber, and the 10-meter duplex glass fiber optic cable (for the latter, use one of the fibers only).
11. Answer Questions 11 and 12 on **Worksheet #7**.

Table 9. Position of Receiver Gain knob for various fiber cable lengths.

CABLE LENGTH AND TYPE	KNOB POSITION
1-meter glass optical fiber	
3-meter glass optical fiber	
10-meter glass optical fiber	
1-meter 1000 μm core optical fiber	
3-meter 1000 μm core optical fiber	
10-meter 1000 μm core optical fiber	

Procedure B

1. Unroll the 1-meter 1000 μm core optical fiber and lay it in a large arc.
2. Insert an ST connector from the 1-meter 1000 μm core optical fiber into the fiber optic LED (FO LED) as follows: Align the key on the connector body with the slot on the ST receptacle, then gently push in. Rotate and push the knurled locking ring until the slots engage the bayonet ears on the ST receptacle. Continue twisting against the spring tension until the knurled ring snaps and locks over the bayonet ears.
3. Insert and lock the other end of the 1-meter 1000 μm core optical fiber into the fiber optic photodetector (FO DET).
4. Turn the Signal Generator Frequency knob clockwise completely full scale (highest frequency).
5. Adjust the Receiver Gain knob until the green LED just begins to light. This adjustment is sensitive, so perform it several times until the knob position is consistent. Record the position of the knob in **Table 8** either pictorially, in degrees of rotation (assume 0 degrees is straight up).
6. Repeat steps 1 through 5 for the 3- and 10-meter 1000 μm core optical fiber.
7. Answer questions 13, 14, and 15 on **Worksheet #7**.

#

Worksheet #7

Student: _____

1. Which two of these optic receiver parts are most critical to operation? (Circle the correct answers.)
 - a) Photodetector
 - b) Preamplifier
 - c) Main Amplifier
 - d) Signal Processor
2. _____ is the common material used for detecting visible and infrared radiation from 400 to 1050 nm.
3. Name the two most common types of light detectors used in fiber optic telecommunications receivers.

4. Light photons can create no more than a single electron and hole in a photodiode.
 - a) True
 - b) False
5. What does the acronym APD stand for? _____
_____ .
6. A phototransistor has a much faster response time than a photodiode.
 - a) True
 - b) False
7. "Transimpedance amplifier" is sometimes used as the name for what fiber optic receiver component? _____
8. How does the avalanche photodiode get its name?
9. All fiber optic receivers must have a drive circuit for the LED or laser diode.
 - a) True
 - b) False

10. The housing, optical interface and electrical interface are very similar in fiber optic transmitters and receivers.
 - a) True
 - b) False

11. Is the position of the Receiver Gain knob the same or significantly different for the 1-, 3- and 10-meter lengths of glass fiber optic cable?

12. In this measurement, does the 10-meter glass fiber optic cable have a noticeable loss compared to the 1-meter length?

13. Is the position of the Receiver Gain knob the same or significantly different for the 1-, 3- and 10-meter lengths of 1000 μm core optical fiber?

14. Based on the data in **Table 9**, which fiber optic cable type demonstrates lower attenuation with distance using the Lab Module as an instrument?

15. Explain the answer to question 14. (Hint: Review the reading material in **Activity #5** and **6**.)

EXPAND AND NETWORK

ACTIVITY # 8:

One pair of fiber optic cables can carry more telephone conversations than 1,000 pairs of copper cable. Even in short-distance applications where copper works well, many major cities simply don't have enough spare room in their electrical conduits to install any more large bundles of copper wire, so optical fibers are replacing existing copper cabling. Fiber optics has an added edge over copper because it uses photons, rather than electrons, to carry signals. That means fiber optic systems don't radiate Radio Frequency Interference which can conflict with other electronic equipment, nor are they affected by it. In this activity you will look further into a fiber optic system and learn about some components that give fiber optics more versatility. In the Lab Demonstration we will use Lab Modules to construct an important part of a fiber optic system, an electronic repeater.

Equipment Needed:

- 2 Lab Modules
- 2 120-VAC-to-12-VDC power adapters, with cord
- 2 3-meter glass optical fibers
- 2 Orange banana-to-yellow banana plug wire test leads
- 1 Brown banana-to-brown banana wire test lead

To complete this activity, you must:

1. Complete **Reading Assignment #8**.
2. Answer Questions 1 through 10 on **Worksheet #8**.
3. Discuss one of the two patents that you researched for **Homework Assignment #7** with your lab partner or group.
4. Complete **Lab Demonstration #8 - Creating a Fiber Optic Repeater**.
5. Complete **Homework Assignment #8**.

Homework Assignment #8:

Log onto the Internet and check out the web sites <http://fiberoptic.com> and <http://photonicsnet.com>. Find one product and newsworthy article and write 50 to 100 words describing what the author was saying.

LONG DISTANCES AND FIBER NETWORKS

Reading Assignment #8

In the previous activities we have discussed and shown simplified diagrams of light, optical fiber, light sources, transmitters, photodetectors and receivers, which might lead you to think there is only one of each in a fiber optic system as shown in Figure 25. Real world applications, however, require these simple diagrams to expand to include capabilities for:

- amplification for very long distances
- distribution of signals to multiple locations

Long Distances

All types of signals, whether carried by copper or fiber, lose strength, the greater distance they travel. Although fiber optics is much more advantageous when compared to copper-based cabling, after a point even optical signals in fiber optics can't be detected or interpreted reliably. To get around the problem of signal attenuation (strength loss), both copper and fiber-based systems rely on some form of repeater—devices which amplify a signal along its path as shown in Figure 26.

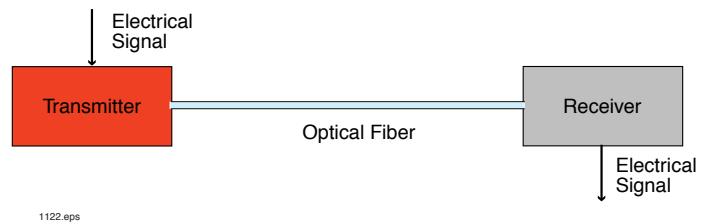

Figure 25. Simple point-to-point fiber optic communication system.

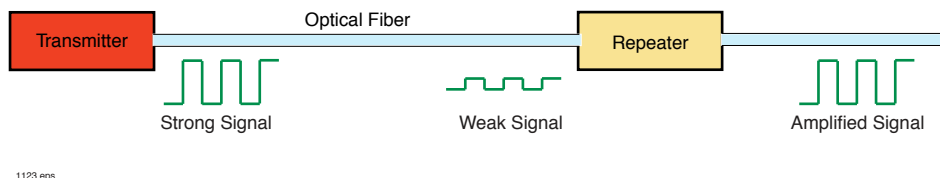

Figure 26. Fiber optic system using a repeater to counteract the effects of attenuation.

Copper cable TV systems require repeaters about every kilometer. Fiber optics dramatically better that performance; repeaters may be needed only every 50 kilometers! Fewer repeaters means less expense to install them and maintain them, and that's especially important when dealing with undersea, transoceanic telephone cables. The cost to haul the big cables up from several thousand feet below the water surface to install or repair repeaters rapidly becomes prohibitive, or in some cases physically impossible.

Repeaters

Although we described a repeater previously as a simple device that amplifies an incoming signal, it is a little more complex in fiber optics, and there are also two types of repeaters. The repeater types, based on different technologies are:

- Electronic
- Optical

Most installed fiber-optic systems (1998) use electronic means of amplification. They first convert the input optical signal into electronic form, then amplify it and send it to a driver and other optical transmitter. You can think of an electronic (electro-optic) repeater as a receiver and transmitter placed back to back, so the receiver drives the transmitter as shown in Figure 27. Their overall function and performance is very similar to that of electronic repeaters used for communications systems such as cable TV.

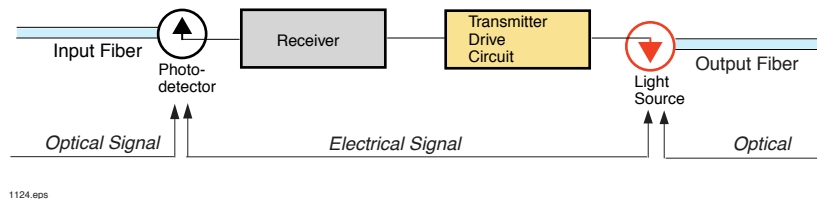

Figure 27. Electro-optic repeater.

Optical Amplifier

Conceptually an optical amplifier is very simple. Its simplicity ultimately promises lower costs, because it contains few components. Optical amplifiers offer high reliability and versatility. In contrast to the electrical repeater, the optical amplifier takes a weak input optical signal and amplifies it directly to generate a strong signal. It does not convert a light signal to an electronic one before amplifying it.

The optical amplifier is a very recent technology advancement. Its first major commercial use was in a 2.5 Gigabit-per-second 294 km fiber link between Denmark and Norway in 1995. In September of 1996 the Transatlantic Telephone cable system became operational, linking England, France and United States with 10 Gigabit-per-second capability. Planning is currently under way to increase this link to 40 Gigabit, with no modifications to the optical amplifiers.

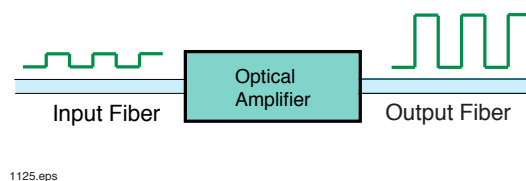

Figure 28. Optical Repeater

Electro-optical repeaters must be designed to operate at a specified format and data rate such as 150 Megabits per second. To convert a fiber system using electro-optical repeaters to transmit at 300 Megabits per second requires replacing all of the repeaters. The optical amplifier, on the other hand, can amplify multiple data rates and wavelengths and is

flexible enough to be used for any analog or digital format. Optical amplifiers are higher priced than electro-optical currently, but costs are dropping. As manufacturing costs go down, this type of repeater will almost certainly become the dominant one used in long-distance communications worldwide.

An optical amplifier works in a manner very similar to that of a laser except, as shown in Figure 29, it does not have reflective mirrors at the ends. Light makes only a single pass through the amplifier. Energy is input into an optical amplifier and stored by atoms with electronics in an upper "charged" state. When a photon comes along and bumps the atom, the photon stimulates the atom so that its charged electron falls to its normal state, during which a photon is produced. This second photon is an exact clone of the first photon in wavelength, polarization and direction of travel. The two photons continue down the optical amplifier where the process repeats, or the end of the fiber amplifier is reached. Amplifications from these optical amplifiers range from 10 to 1000.

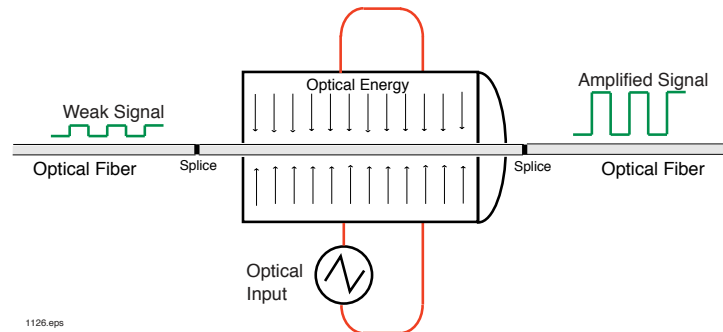

Figure 29. Optical amplifier operating diagram.

Optical Distribution

So far we have discussed fiber optic communication systems as having a transmitter on one end and the receiver on the other and often some repeaters in the middle. Although this is fine for transcontinental fiber optics, or point-to-point communications, many applications require splitting or distributing a signal into several components. Examples of applications needing multiple distribution capabilities include cable TV, multiple telephones and Internet access.



Photo 16. Optical fiber power amplifier. (Photo courtesy of Newport Corporation)

Because light can not be split off like we might add 120-VAC household outlets, some special devices called couplers were created for fiber optics. These devices can come in several different configurations as shown in Figure 30. Each coupler design has its specific applications. The "tree" style coupler would be great for a cable TV distribution where there is one source and many destinations. The star coupler would be ideal for a computer network where every user would like to be connected to every other user. Very advanced fiber optic couplers are now being used to add and subtract several optical wavelengths to and from a fiber.

Information Networks

As our information-intensive world becomes more and more complex, existing systems are looking for ways to interconnect with others and to make the data itself more available to us. That's where the concept of networks comes in. Ideally, in the future, the whole data industry will be built around worldwide specification standards which permit all pieces of every telecommunications system to "work" with all other pieces of equipment. The result will be one huge network, consisting of many smaller ones in which all users can "talk" to each other. Large companies, for example, may use networks to connect the personal computers of hundreds or even thousands of employees at multiple locations around the world. One huge network that you have used in this curriculum is the Internet.

Fiber optics has an important role to play in these networks, especially because of its enormous bandwidth or information-carrying capabilities. Local Area Networks (LANs) and Wide Area Networks (WANs) are two types of networks which already exist.

To improve network reliability, the International Standards Organization in 1978 recommended a network "architecture" which defined a common set of rules which specify how parts of a network should interact and exchange information. The intended result is that one network should be able to connect to other networks, whether they are of the same or a different type. Examples of different LAN network topologies are shown in Figure 31. (Notice how similar these are in shape to the fiber optic couplers shown in Figure 30.)

In a star LAN, information goes out from a central hub to individual users (computer stations, for example). In a ring LAN, information travels around the oval, but must go "knocking at the door" of each user station until it arrives at the correct addressee (the person for whom a specific message was intended). The star LAN tends to be more reliable because if there is a break in the cable, only an isolated portion of the system goes down. With ring LANs, the whole system may fail.

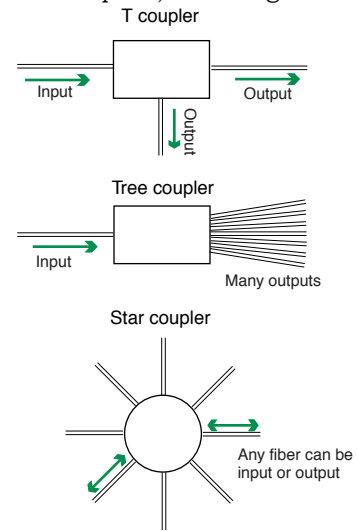

Figure 30. Fiber optic coupler configurations.

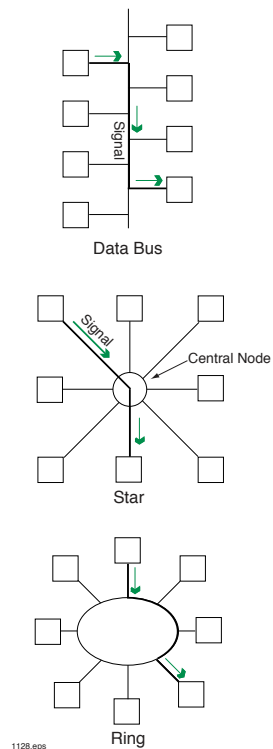

Figure 31. Data bus, Star and Ring LAN network architectures.

Besides the geometry of how a network is to be laid out, there are data format standards. Examples of such standards include:

- IEEE 802.5 Token-Ring (4 or 16 Megabit/second)
- Ethernet (10 Megabit/second)
- Fiber Distributed Data Interface [FDDI] (100 Megabit/second)
- Asynchronous transfer mode [ATM]

FDDI is a recent system that was designed for fiber optics from the start. It has a dual fiber system as shown in Figure 32 and is designed so information passes in both directions. Normally one ring carries the information while the other is kept in reserve in case of component or cable failure. The data transmission rate is 100 Megabit/second in each direction. The FDDI standard also specifies a concentrator type of node where other networks such as Ethernet or Token-Ring can be connected.

It may well be that some time in the near future, LANs will be integrally linked to the huge telecommunications networks operated by the telephone companies. Already computers are handling telephone functions such as voice mail, FAX and video conferencing. More sophisticated LANs are being developed even as you read this. Without a doubt, fiber optics will play a very important part in this technological evolution.



Photo 17. Fiber optic tree star coupler in a 2 x 2 configuration.

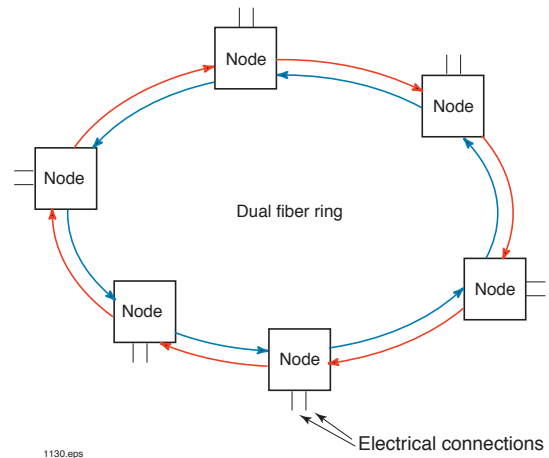

Figure 32. FDDI fiber LAN showing the two counter-propagating signal paths.



Photo 18. Glass optical fibers are very small in diameter as can be seen by the multiple fibers through this needle's eye.

CREATING A FIBER OPTIC REPEATER

Lab Demonstration #8

In this demonstration you will use the three basic fiber optic building blocks to construct a fiber optic electronic repeater. You have used these building blocks before. They are transmitters, fiber and receivers. You may be amazed at how simple a fiber optic repeater is, and how easy it is to create a long network.

An AT&T or Sprint fiber optics network has a sending station, multiple repeater stations and a receiving location. In this demonstration Location 1 is the sending location. In an AT&T network, the sending location would be a telephone, the local electrical network, and a fiber optic transmitter. In this experiment the signal generator will substitute for the telephone. Location 2 will be the fiber optic repeater. Its receiver channel detects the optical signal, amplifies it, and converts it back into light for transmitting over another length of cable. In a telephone network, the fiber output of Location 2 would travel on to a third repeater or to a final receiving station. The receiving station is a fiber optic receiver and another telephone.

If you have more than one of these fiber optic trainers, they can be cascaded in series. If you have more than two Lab Modules, you can proceed to Procedure B when you've finished Procedure A.

Procedure A

1. Choose a flat, level location approximately 60 × 240 cm (2 × 8 feet) to assemble the repeater system.
2. Place one each of items 1 through 3 from the Equipment Needed list at each location. Location 1 will be the left side of the table. Place both the orange-to-yellow banana test leads at Location 1. Place the brown banana-to-brown banana test lead at Location 2—the right side of the table.

Location 1

3. Insert the yellow plug of one test lead into the **Signal Generator's** digital output, and the orange plug into the **Momentary Switch's** orange jack.
4. Insert the yellow banana plug of the other test lead into the yellow jack of the **Momentary Switch**. Then, insert the orange banana plug into the orange jack of the **Transmitter**.
5. Insert the small end of the 120-Volt Power Adapter cord in the black plastic jack located in the very left-center portion of the Lab Module (located just above and to the left of the Speaker).

6. Insert the two-pronged end of the Power Adapter into a 120-volt wall outlet or extension cord. The yellow LED labeled On (located just above the black power input jack) should light up on the module. If not, make sure the ends of the Power Adapter are firmly plugged in.
7. Turn the Signal Generator frequency control to its minimum counter-clockwise position. (The position of the Signal Generator's gain control knob will have no effect in this experiment.)
8. Locate the fiber optic LED (FO LED)) ST receptacle in the upper right portion of the Lab Module at Location 1. Insert an ST connector from one of the 3-meter optical fibers into the receptacle as follows: Align the key on the connector body with the slot on the ST receptacle, then gently push in. Rotate and push the knurled locking ring until the slots engage the bayonet ears on the ST receptacle. Continue twisting against the spring tension until the knurled ring snaps and locks over the bayonet ears.

Location 2

9. Plug one end of the brown banana-to-brown banana test lead into the white digital receiver jack and the other end into the orange jack of the **Transmitter**. This is one of the very few times it is okay not to color-match the test lead's banana plugs with the jacks on the Lab Modules.
10. Locate the fiber optic photodetector (**FO DET**) ST receptacle in the lower right portion of the Lab Module at Location 2. Insert the ST connector from the 3-meter optical fiber hooked to the fiber optic LED (FO LED) at Location 1. Leave the remaining 3-meter cable unhooked.
11. Turn the **Receiver Gain** knob fully counter-clockwise to reduce gain to a minimum.
12. Insert the small end of the 120-Volt Power Adapter cord in the black plastic jack located in the very left-center portion of each Lab Module (located just above and to the left of the Speaker).
13. Plug the two-pronged end of the Power Adapter into a 120-volt outlet. The yellow LED labeled **On** (located just above the black power input jack) should light up. If not, check all of your electrical 120-VAC connections.
14. Observe that the red LED in the digital portion of the receiver at Location 2 is on.
15. Have one person in your group press the **Momentary Switch** on Location 1 to begin transmitting. Observe the yellow LED just above the **Momentary Switch** at Location 1.

16. Observe Location 2's green and red digital indicators.
 17. Answer Question 11 on **Worksheet #8**.
 18. While holding down the momentary switch at Location 1, turn the **Receiver Gain** knob clockwise at Location 2 until the red and green LEDs in the receiver are both blinking.
 19. Ask someone at Location 1 to release the **Momentary Switch**.
 20. Answer Question 12 on **Worksheet #8**.
 21. Un-lock the connector on the fiber optic photodetector (**FO DET**) ST receptacle at Location 2 and pull the connector out about 3 mm (1/8 inch). Tape or anchor the cable so it will not change position inside the receptacle.
 22. Answer Question 13 on **Worksheet #8**.
 23. Increase the **Receiver Gain** at Location 2 until red and green are alternately flashing again.
 24. Re-insert and lock the fiber connector into the photodetector (**FO DET**) at Location 2.
 25. Increase the frequency of the **Signal Generator** while holding down the **Momentary Switch** at Location 1.
 26. Observe the red and green LEDs of the receiver at Location 2.
 27. Answer Question 14 on **Worksheet #8**.
- If you are planning to complete **Procedure B**, skip Step 28 in **Procedure A**.*
28. Unplug both power adapters from the 120-volt outlet and the lab modules. Unhook the ST connectors, roll up the optical fibers and return all items to their proper storage containers and locations.

You have just seen how the signals originating at Location 1 were amplified and re-transmitted at Location 2. Many long-distance national and international phone lines utilize fiber optic repeaters using the same building blocks and principles that you have applied in this demonstration.

Procedure B (Optional)

If you have additional Lab Modules, they can be added as more fiber optic repeaters for a link more representative of a long-distance fiber optic network. To do so, follow the steps below for each additional repeater or Lab Module.

1. Plug one end of a brown banana-to-brown banana test lead into the white digital receiver jack and the other end into the orange jack of the transmitter circuit.
2. Install a fiber between the LED at Location 2 into the fiber optic detector of Location 3.
3. Set the Receiver Gain of the Location to 2/3 of full scale.
4. Insert the small end of the 120-Volt Power Adapter cord in the black plastic jack located in the very left-center portion of each Lab Module (located just above and to the left of the speaker).
5. Insert the two-pronged end of the Power Adapter into a 120-volt wall outlet. The yellow LED labeled On (located just above the black power input jack) should light up on both modules. If not, make sure both ends of the Power Adapter are firmly plugged in.

Adjust the gain of the receiver so the green and red receiver LEDs turn on and off reliably. The **Momentary Switch** of Location 1 must be pushed for the green LED at Location 3 to blink.

To add a fourth or fifth repeater station, repeat steps above.

#



Photo 19. Special effects are created as light leaves optical fibers.

Worksheet #8

Student: _____

1. A fiber optic cable can carry how many telephone calls as compared to conventional copper wire?
 - a) 1
 - b) 10
 - c) 25
 - d) 100
 - e) >1000

2. Fiber optic systems never need amplification from one end to the other.
 - a) True
 - b) False

3. Fiber optics are good only for point-to-point communication networks.
 - a) True
 - b) False

4. What are the two types of fiber optic repeaters?

5. An optical repeater converts the optical signal from a fiber optic cable into an electrical signal before amplifying it.
 - a) True
 - b) False
 - c) Only in the case of gamma repeaters

6. An optical repeater:
 - a) Has the potential of low cost
 - b) Has high bandwidth capabilities
 - c) Can amplify multiple wavelengths
 - d) Is useful for analog and digital formats
 - e) All of the above

7. Fiber optic couplers include:
 - a) Tree
 - b) Star
 - c) Ring
 - d) Hex
 - e) a and c
 - f) c and d
 - g) a and b

 8. Networks are being used less and less by companies because more individuals are working at home.
 - a) True
 - b) False

 9. LAN configurations include:
 - a) Star
 - b) Ring
 - c) Data Bus
 - d) All of the above
 - e) None of the above

 10. Fiber Distributed Data Interface (FDDI) is very old and slow.
 - a) True
 - b) False

 11. Do the red and green LEDs blink at Location 2 when the Momentary Switch at Lab Module 1 is pressed? Why or why not?

 12. Do the red and green LEDs at Location 2 continue to blink when the **Momentary Switch** at Location 1 is released? Is the blinking red LED at Location 2 in phase (or time) with the yellow LED just above the **Momentary Switch** at Location 1?
-

13. Are the red and green LEDs still blinking at Location 2 when the **Momentary Switch** at Location 1 is pressed? Why or why not?
14. Do the red and green indicators increase their blinking rate as the **Signal Generator's** frequency is increased at Location 1? Is the light out of the 3-meter fiber at Location 2 in phase with the red or green LEDs?

FIBER OPTIC TOOLS AND CONNECTORS

ACTIVITY # 9:

This activity will explore how fiber optic components are linked. Electrical wire and cables are usually hooked together with connectors and splices to connect various components in a system. Fiber optic systems have similar needs but use different parts and techniques to achieve the same purpose. In this activity we will discuss various connectors and splices, along with tools and measuring instruments used to establish high-quality terminations in fiber optic systems. The Lab Demonstration will demonstrate the effects of bending losses in a fiber link, and outline the typical steps in preparing a fiber optic termination.

Equipment Needed:

- 1 Lab Module
- 1 120-VAC-to-12-VDC power adapter, with cord
- 2 3-meter glass optical fibers
- 1 Orange banana-to-yellow banana plug wire test lead
- 1 Brown banana-to-brown banana plug wire test lead

To complete this activity you must:

1. Turn in **Homework Assignment #8** to your Lab Instructor.
2. Complete **Reading Assignment #9**.
3. Complete **Lab Demonstration #9 - FIBER TERMINATIONS**.
4. Answer Questions 1 through 10 on **Worksheet #9**.
5. Complete **Homework Assignment #9**.

Homework Assignment #9:

Review the **Pre-Test** that you took at the beginning of this module and all of your worksheets.

OPTICAL INTERCONNECTIONS AND TOOLS

Reading Assignment #9

Electronic devices are often interconnected either to form a larger system or to exchange information or data. An example of this is the local telephone system, which has electronic devices (such as a telephone) connected with copper wires to large switching networks. The wire carries power and signals from the phone to the switching office, and electrical connectors are used to link the wire to various devices in the system.

So far in our discussion about fiber optics, we have mentioned optical fiber, networks, transmitters and receivers, but we have not described how these elements are connected to each other. Fiber optic cable performs a function similar to that of copper wire, and connectors are similarly used to attach fiber to the many devices in a fiber optic system. In this section we will discuss several connection methods and tools used with optical fiber components.

Linking optical fibers and devices

In electronic systems, electrical current or energy is used either to transfer power or carry information among components and subsystems. Fiber optic systems use optical energy primarily to carry information or data. Regardless of data format or transmission rate elements of a fiber optic system, three fundamental actions are performed among the various components and subsystems. A component is emitting optical energy (LEDs and Lasers), transferring optical energy (fiber optic cables and couplers), or receiving optical energy (phototransistors and photodiodes).

To link these fiber optic components so optical energy can be transferred within the system, two primary methods are used:

- Connectors
- Splices

Connectors most often are used to link fiber optic cable to photodetectors or LEDs. The devices are packaged in a housing which accepts a connectorized fiber optic cable, permitting efficient transfer of optical energy between the cable and optoelectronic component. Splices most often are used to permanently connect two fiber optic cables. While connectors can also be used for attaching two fibers, splices generally are lower in loss and more permanent. Connectors are removable, and therefore more flexible, when interchanging components within a system. **Table 10** shows a comparison between connectors and splices.

Table 10. Comparison of fiber optic connectors and splices.

CONNECTORS	SPLICES
Removable	Permanent
Can be factory-installed	Can be field-installed
Can be field-installed	Lower attenuation/reflection than connectors
Easy to reconfigure	Strong, compact junction
Provide standard interface	Lower cost per connection
	Easier to fit inside conduit

Connectors

In many electronic systems, the ability to add, change, or remove components or subsystems is a necessity. The reasons may include equipment expansion, repairs, or upgrades. Electrical connectors are crucial items in performing these activities with a minimum of labor and time, permitting rapid exchange of components which have the same connector type. An everyday example of an electrical connector is the power line cord on many common appliances. Imagine the inconvenience of having to permanently wire an appliance to the power grid in your home and you can appreciate the convenience an electrical connector can provide. There is a strong need for connectors in fiber optic systems for the same reasons.

Just as there are many different electrical connectors, a variety of fiber optic connectors exist, including SMA, SC, ST, FDDI, Biconic and DNP simplex. Each connector type has unique characteristics which provide advantages, depending on the application. An ST connector, as is used in this curriculum, is built around a cylindrical ferrule that mates with a coupling receptacle. The outer connector body is a spring-loaded bayonet socket allowing quick engagement with the coupling receptacle. ST connectors are popular in data communications and medium-distance applications.



Figure 33. ST fiber optic connector with glass fiber installed.

Regardless of type, all connectors share common design attributes. They provide a strain relief to isolate the fiber from mechanical stress, a ferrule to capture and align the fiber, and a body to contain the ferrule so it can be attached to mating receptacles. Figures 33 through 36 show various connector types commonly used in the fiber optics industry.

The installation of a connector onto a fiber optic cable is similar in concept to attaching an electrical connector; however, the process requires more care, precision and time.

Special tools often are required, and each connector type has a unique procedure, although many steps are common to all. The following describes a typical installation sequence:

- Cut fiber optic cable to desired length
- Slip strain relief over jacket
- Remove layers to expose optical fiber
- Pre-trim fiber end to length
- Insert fiber into ferrule
- Epoxy or crimp fiber cable into connector
- Polish fiber end and inspect with microscope

The goals of any connector installation procedure are to anchor the fiber in a protective mechanical housing, ensure it is properly aligned, and provide a smooth fiber tip finish to maximize transmission.

Some connectors are designed to reduce the installation steps needed for a good assembly. An example of this is the plastic DNP (dry, no-polish) simplex connector. It is a low-cost connector for plastic optical fiber links under 30 meters in length, and uses no epoxy or crimp to hold the fiber to the connector plug. The fiber jacket is stripped, the fiber end is cut with a knife or razor blade then inserted and held in the connector plug containing a barbed retention clip. The whole process takes less than a minute.

Other approaches for linking fiber optic cables and system components use no connectors whatsoever. An example of this is the fiber optic LEDs and photodetectors manufactured by Industrial Fiber Optics. These LEDs and photodetectors are contained in housings which accept plastic fiber directly. The fiber end is cut with a razor blade, inserted carefully into the component housing, then held in place with a cinch nut. The internal construction of the housing accurately aligns the fiber with the photodetector or LED for maximum transfer of optical energy. This connector-less termination type is used only with plastic fiber. To view these types of components please go to our web site www.industrialfiberoptics.com.

All connectors have attenuation or loss of optical energy within the connector when installed. There are several causes of such attenuation. Some are due to the mechanical alignment of the fiber, and others result from the quality of the end finish. As an example, assume two fiber cables with connectors are attached to each other. If the fiber ends are misaligned so that the area of one fiber core does not completely overlap the other, some light will be lost where there is no overlap. Any tilt in the axis of



Figure 34. SMA fiber optic connector.

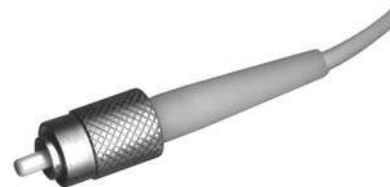

Figure 35. FC fiber optic connector with glass fiber installed.



Figure 36. DNP simplex plug with 1000 μm core plastic optical fiber installed.

the fiber ends may cause light to leave the confines of the collection angle of the fibers. A gap between the fiber ends may cause light exiting one fiber to spread outside the collection diameter of the other. In fibers with poor end finish, light will be absorbed, reflected, or scattered by the irregularities on the fiber ends. Finally, any gap between fiber ends will cause the index of refraction from the discontinuity (glass to air to glass), resulting in a Fresnel loss. This can be significantly reduced by the use of index-matching gel.

Splices

When a low-loss and permanent fiber connection is needed, the preferred joining method is a splice. The goal of a splice is to accurately join two fiber ends while providing negligible interruption to the flow of optical energy. Splices have low loss, typically 0.05 to 0.2dB, vs. 0.2 to 0.7dB for connectors. In a system with many interconnections this advantage can be significant. There are two primary methods of splicing fibers are: fusion and mechanical. Fusion splicing joins fibers by melting them together with heat. In a mechanical splice the fiber ends are carefully finished and held together in a structure with glue or a clamping device.

Fusion splicing requires special (and expensive) equipment containing an electric welder and a precision mechanism for aligning fibers. They often include a video camera or microscope so the operator can observe fibers during the alignment process, and instruments to measure optical power before and after splicing. Many of them are automated to assist the operator. Fusion splicing two fibers involves several steps. First, the fiber ends are exposed by stripping back any protective buffer or jacket. Then the ends are cleaved to provide clean perpendicular faces and aligned manually or automatically so they butt together accurately. Finally, an electric arc is established to weld or fuse the two ends together with heat. The resulting joint is measured optically to ensure low loss, then protected mechanically and environmentally with either a coating or enclosure. The cost of a fusion splice is low compared to a typical connector because less mechanical hardware is required.



Photo 20. Fusion splice for glass optical fiber.

Mechanical splices come in a variety of forms, similar to connectors. Several types include capillary, rotary ferrule, V-groove and elastomeric. Regardless of type, the crucial aspect of these splices is fiber end preparation. A clean, perpendicular end-face is essential to minimize the loss between fibers. Very often an index-matching gel is used in the splice to further reduce Fresnel reflections in the interface. Once the fiber ends have been prepared by stripping and cleaving, they are inserted into the splice housing. Certain splice types, such as the rotary ferrule, allow adjustment of the fibers while monitoring with a power meter to minimize loss. Once the fibers are in an optimum position, they are either retained by compression, friction, or a UV-cured epoxy. Mechanical splices cost

more than fusion splices, but don't require expensive equipment, and may make more sense where fewer interconnections are needed.

Special tools and equipment

Several types of equipment and tools are unique to the fiber optic industry. In function, many of them are similar in concept to those used in other industries, specifically the field of electronics. They differ in that optical fiber and light energy are being manipulated instead of copper wire and electrical energy. Some of the equipment includes fusion splicers, OTDRs, power meters and light sources. Typical hand tools include cable strippers, fiber cleavers, scribes and polishing pads.

Power meters are a fundamental piece of equipment used in fiber optics, much as a voltmeter is used in electronics. Power meters measure optical energy coming out of a fiber, transmitter, repeater, or other optoelectronic devices used in a fiber optic system. They often are similar in appearance to the digital voltmeters used in electronics; however, they measure optical power in units of watts or dBm. Power meters consist of a photodetector (and appropriate input connector) and a read-out device to measure the light-induced current from the detector. A power meter can be used to measure the total quantity of optical power coming from a fiber or transmitter, and when properly configured, the attenuation or loss through fiber cables and connectors. Photo 21 is of a power meter designed for use with plastic optical fiber. (Available from *Industrial Fiber Optics*. Contact us or one of our distributors for more information.)

An Optical Time Domain Reflectometer or OTDR is a powerful but costly measurement instrument used to troubleshoot fiber optic links. It is similar in purpose to Time Domain Reflectometers used in electronics, and behaves like an optical radar system. It sends a short light pulse down a fiber cable and monitors any light that is reflected or scattered back. By plotting the returned light energy vs. time on a screen, an operator can locate discontinuities or breaks where optical loss is occurring. A point in the system with a loss or discontinuity will show up as a peak on the screen. Connectors, splices and fiber ends all will show up as peaks on a sloped line, and the distance to the peaks can be read from the display. Using an OTDR



Photo 21. Optical power meter with a built-in light source.



Photo 22. OTDR Instrument.

requires care and experience, but it provides a powerful tool in the hands of a skilled operator.

Light sources are used to provide optical energy that can be coupled to a fiber optic system. When used in conjunction with an optical power meter, they allow measurement of loss through fibers, connectors and splices. Some sources have sophisticated electronics permitting accurate adjustment of the optical power level, and in some cases, modulation of the optical power. These can be used to check the performance of fiber optic receivers and individual photodetectors.

A fiber cleaver is a special tool whose purpose is to cut and separate glass fiber, resulting in clean, perpendicular ends with no irregularities or damage. In its simplest form a cleaver consists of a carbide blade for scribing the fiber, and a fixture to hold the fiber under tension before separation. The cleaving procedure involves scribing a fiber under tension to form a small weak spot in the crystalline structure of the glass. Pulling on the fiber causes a crack across the fiber's diameter in line with the scribe point. When cleaving is done properly, the fiber breaks along a flat perpendicular path because of the glass's structure. Cleavers can be elaborate hand-operated tools resembling a knife or chisel, to semi-automatic machines.

Other tools used in fiber optics include small hand-operated ones such as strippers which have cutting blades for removing cable jackets and coatings from fibers. These are usually designed so the blades cut very close to, but do not nick, the fiber core and cladding.



Photo 23. Tool for cleaving the end of an optical fiber. (Photo furnished by Clauss.)

Polishing tools are used to provide a fine surface finish to connectorized fibers. They usually include a holder for the connector ferrule, and polishing pads of various grits to successively grind the fiber tip to a smooth finish. A variety of automated polishers are available which eliminate much of the hand labor. Finally, crimping tools are also used to anchor fiber cable strength members to various connector bodies to provide mechanical strain relief.

FIBER TERMINATIONS

Lab Demonstration #9

In a previous activity we learned how light is lost or attenuated in a fiber because of absorption within the fiber material. In this Lab Demonstration, we will observe losses caused by bending. While light generally stays within a fiber as it travels down its length, some will escape if the fiber is bent or curved sufficiently. We will also outline a typical procedure for terminating a fiber with a connector.

Procedure A

1. Choose a flat, level location approximately 60 × 120 cm (2 × 4 feet) in size on which to conduct this experiment.
2. Insert one end of the orange-yellow test lead into the yellow jack of the Signal Generator with the word “Digital” below it. Insert the other end into the orange Transmitter jack.
3. Insert the small end of the 120-VAC Power Adapter cord into the black plastic jack at the center left portion of the Lab Module (just above and to the left of the Speaker).
4. Insert the two-pronged end of the Power Adapter into a 120-volt wall outlet. The yellow LED labeled **On** (located just above the black power input jack) should light up. If not make sure both ends of the Power Adapter are firmly plugged in.
5. Unroll the 3-meter glass fiber optic cable and lay it in a large arc.
6. Insert an ST connector from the 3-meter glass fiber optic cable into the fiber optic LED (FO LED) as follows: Align the key on the connector body with the slot on the ST receptacle, then gently push in. Rotate and push the knurled locking ring until the slot engage the bayonet ears on the ST receptacle. Continue twisting against the spring tension until the knurled ring snaps and locks over the bayonet ears.
7. Insert the remaining ST connector of the 3-meter glass fiber optic cable into the fiber optic photodetector (FO DET).
8. Turn the Signal Generator Frequency knob to the 3 o’clock position.
9. Adjust the Receiver Gain knob until the green LED just begins to light. This adjustment is sensitive so perform it several times until the knob position is consistent. Record the position of the knob in **Table 11**, in degrees of rotation (assume 0 degrees is straight up).
10. Remove the ST connector from the fiber optic photodetector (FO DET) and put three 300 cm (12-inch) diameter loops in the fiber. Re-attach the ST connector and repeat Step 9.

11. Repeat Steps 9 and 10 for the remaining loop configurations shown in **Table 11**. For the smaller loops, it may be helpful to wind the cable around a cylindrical object and tape it place.

Table 11. Position of Receiver Gain knob for various fiber cable loops.

12. Answer questions 11, 12 and 13 in **Worksheet #9**.

Procedure B (for reading only)

While similar in concept, attaching a connector to a fiber optic cable generally requires more effort than with an electrical connector. Below is a shortened installation procedure for a typical fiber optic connector used in industry. Some details are omitted so you can easily grasp the key steps required for a high-quality connector installation. In practice, assembly details for the connector manufacturers' specific connector design would be included. Some manufacturers offer special tools that significantly aid connector assembly.

CABLE CONFIGURATION	KNOB POSITION
No Loops - (gentle arc)	
3 loops / 300 cm (12 inches) diameter	
6 loops / 15 cm (6 inches) diameter	
6 loops / 7.5 cm (3 inches) diameter	
6 loops / 3.8 cm (1.5 inches) diameter	

Required Tools

- ◆ Hand-operated crimper (where applicable)
- ◆ Scissors
- ◆ Cable and fiber strippers
- ◆ Polishing bushing and plate
- ◆ Cleaving tool or razor
- ◆ Heat gun (where applicable)
- ◆ Heat cure oven (where applicable)
- ◆ 10X eye loupe or microscope
- ◆ Syringe

Required Materials

- ◆ Epoxy (quick-cure, general purpose, or oven cure type as applicable)
- ◆ Alcohol and paper wipes
- ◆ Polishing paper (coarse, medium and fine grades)

Cable Preparation

1. Identify connector body, crimp sleeve, pre-cut heat-shrink tubing and strain relief. Slide strain relief first (or pre-cut shrink tubing), and crimp sleeve several inches over the unterminated fiber cable end.
2. Adjust cable stripper and strip outer jacket a length equal to 30.2 mm (1.2 inches) from the end of the cable. Trim exposed strength members with scissors so they are even with the trimmed end of the outer jacket, then strip an additional 7.9 mm (.31 inches) from the end of the outer jacket.
3. Mark and strip fiber buffer at 14 mm (.55 inches) from the trimmed end of outer jacket. Clean fiber using alcohol and a paper wipe.

Cable assembly and bonding

4. Mix epoxy according to manufacturer's instructions and load into syringe. Inject epoxy into connector bottom (via knurled end) until a small bead appears at ferrule opening.
5. While removing syringe, simultaneously inject more epoxy into connector until half full. Apply a small drop to the outside knurled end of the connector.
6. Using a twisting motion, carefully insert fiber into connector until it bottoms. Make sure cable strength members are outside the knurled end of connector. The fiber must extend out the front or ferrule end of the connector. NOTE: Be careful not to break the protruding end of the fiber off during the remaining steps.
7. Slide crimp sleeve over strength members until it bottoms on the connector shoulder. Squeeze crimp tool to release ratchet and allow handles to open fully. Place connector body so crimp sleeve lies in the crimp cavity, then squeeze tool handles until ratchet releases again to crimp the sleeve.
8. If applicable, slide heat-shrink tubing over crimped sleeve and apply heat gun until tubing is snug around connector and cable. Otherwise slide strain relief over crimped sleeve. Cure assembly per epoxy manufacturer's instructions—use heat cure oven if required.

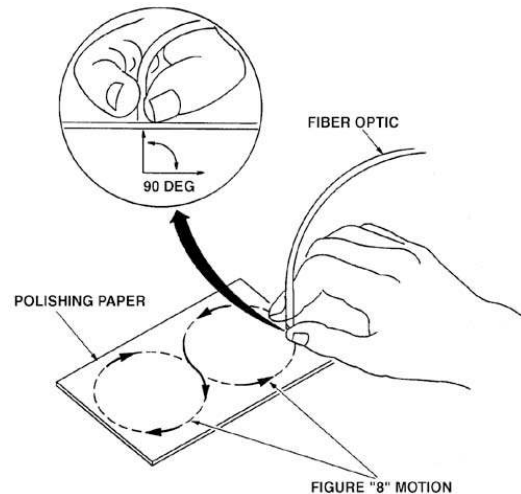

Figure 37. Pattern and positioning of the optical fiber during polishing.

Fiber Cleaving and Polishing

9. Hold connector firmly upright and lightly scribe exposed fiber directly above epoxy on ferrule end. Gently pull fiber straight away from connector to finish cleaving operation. If fiber does not easily pull off, re-scribe and try again.
10. Place a piece of coarse polishing film on polishing plate and place a few drops of water on the film.
11. Insert connector onto the polishing bushing. Hold assembly firmly between thumb and forefinger, then point ferrule toward the polishing paper and lightly polish, using an elongated figure-8 motion as shown in Figure 37. Continue until fiber end is even with the epoxy bead. Add drops of water as needed to keep the action smooth.
12. Clean connector face with alcohol and a paper wipe. Switch to medium polishing paper and repeat polishing process above until a thin layer of epoxy remains above the ferrule.
13. Clean connector face with alcohol and a paper wipe. Switch to fine polishing paper and finish polishing process. Inspect fiber end frequently during the last stages of polishing using an eye loupe or microscope. Do not over-polish.
14. Answer questions 14 and 15 on **Worksheet #9**.

#



Photo 24. Fiber optics is used to transfer data at this wind-powered electric generating site because of low weight and noise-free transmission.

Worksheet #9

Student: _____

1. To link fiber optic components, which items are used?
 - a) Electrons
 - b) Protons
 - c) Splices
 - d) Cosmonauts
 - e) Connectors
 - f) None of the above
 - g) c and e

 2. Fiber optic systems never need to be changed or reconfigured.
 - a) True
 - b) False

 3. SMA and ST are names for what type of fiber optic components?
 - a) Splices
 - b) LEDs
 - c) Laser
 - d) Fiber cable
 - e) Connectors
 - f) None of the above

 4. Fiber optic connectors permanently attach items or components.
 - a) True
 - b) False

 5. Fiber end finishes are not important for operation of a fiber optic system.
 - a) True
 - b) False

 6. All fiber optic cables must have connector ends applied to them.
 - a) True
 - b) False

 7. Splices can be of what types for optical fiber?
 - a) Mechanical
 - b) Organic
 - c) Delayed
 - d) Abstract
 - e) a and b
 - f) None of the above
-

8. Fiber optics connections may require special tools.
 - a) True
 - b) False

9. Fusion splices weld two optical fiber ends together by means of:
 - a) Photons
 - b) High pressure
 - c) Electrical arc
 - d) Sonic waves
 - e) None of the above

10. Fiber optics is rapidly becoming a dormant technology.
 - a) True
 - b) False

11. Based on the recorded knob position in **Table 11**, for which configuration did noticeable bending loss in the fiber begin?

12. Using what you have observed, how does a fiber optic cable compare to ordinary telephone wire when it comes to bending?

13. Explain why bending loss occurs when the fiber is bent sufficiently. (Hint: Review the reading material in **Activity #4 and 5**.)

14. How does the effort in terminating a fiber optic cable compare to what you might know about electrical cables or wires?

15. Do you think operator skill is important for achieving high quality fiber optic terminations? Why?

NOTES

Lined area for notes with horizontal blue lines.

WRAP UP *ACTIVITY # 10:*

This activity is the final activity in INDUSTRIAL FIBER OPTICS' *Fiber Optic_Demonstration System*. In this module you undoubtedly will have learned a great deal about fiber optics and light. We hope you enjoyed this course of instruction and will consider a career in this exciting and rapidly developing field.

Equipment Needed:

- All the components that are part of this Lab Module. Please refer to the Parts List on 7 or the detailed description of system components beginning on page 121, Tab 11.

To complete this activity you must:

1. If you have questions about the information in this course of study or **Homework Assignment #9**, ask your instructor to clarify them for you.
2. Inventory all items in this module by going to the following page, during which you will complete column 3 in **Table 12**.
3. Complete the **Final Test** furnished by your Instructor.

Table 12. Inventory Sheet for Lab Demonstration 10.

DESCRIPTION	QUANTITY	ACTIVITY 10
Lab Modules	2	
120-VAC-to-12-VDC power adapters	2	
1-meter Sensor Fiber with ST Connector on one end	2	
1-meter 1000 μm core optical fiber with ST connectors on both ends	1	
3-meter 1000 μm core optical fiber with ST connectors on both ends	1	
10-meter 1000 μm core optical fiber with ST connectors on both ends	1	
1-meter glass optical fiber with orange jacket	1	
3-meter glass optical fiber with gray jacket	1	
3-meter glass optical fiber with orange jacket	1	
10-meter glass duplex fiber with orange jacket	1	
Orange banana-to-yellow banana wire test leads (with blue wire insulation)	4	
Brown banana-to-brown banana wire test leads (with blue wire insulation)	2	
Audio Interface wire test lead (with a black 3.5 mm male jack on one end, and a smaller black male jack and an orange banana plug on the other)	1	
Audio Interface wire test lead (with a black 3.5 mm male jack on one end, and a smaller black male jack and a brown banana plug on the other)	1	
White paper about 5 \times 10 cm (2 \times 4 inches) in size	2	
Black paper about 5 \times 10 cm (2 \times 4 inches) in size	2	
Transparent plastic sheeting about 5 \times 10 cm (2 \times 4 inches) in size	2	
AM/FM radio with 3 AA batteries	1	
Videotape (Optional)	1	

SYSTEM COMPONENTS

LAB MODULES

Power Jack

The power for the Lab Module is input through a 2.1 mm jack. To operate this module, a DC voltage of greater than 14 volts with 200 mA minimum current capability, must be input through this jack. Polarity of input power jack does not matter. Do not input an AC voltage or a DC voltage greater than 20 volts.

Voltage Regulator

The electrical circuits contained with the Lab Module operate from a regulated +12 volt supply. On board voltage regulator circuits conditions the input power to a +12 volts for on board usage.

Microphone Circuit

This circuit uses a Panasonic FET acoustic microphone to pick up audio signals. It has a bandwidth from 20 Hz to 12 kHz. This microphone is AC-coupled to an LM358 audio amplifier configured for a 20X gain. The LM358 amplifier is internally biased, producing in an output at one-half of the supply voltage.

Momentary Switch

This is a simple momentary-close switch. It is normally open, but closes when the button is pushed. Its contacts are rated at 1 amp at 125 VAC. A yellow indicator LED is located above the switch. When the switch is connected to other parts of the module (using the banana jacks) the LED will be off. When the momentary switch is pressed, the yellow LED will light up according to signal transmission. This feature will be used to indicate transmission of data through the module.

Transmitter

The fiber optic light source is an Industrial Fiber Optics red 660 nm LED (IF-E97) specially designed for plastic fiber. The LED driver is a simple voltage follower stage that is DC-biased at one-half of the supply voltage. This 6-volt DC bias level to the base of the driver transistor results in a 6 mA bias current through the fiber optic LED. The maximum drive current through the LED is 50 mA. For all input voltages to the transmitter below 12 volts, the LEDs will be within their safe operating zone. **Do not exceed 12 volts at the input!**

Signal Generator

The signal generator circuit is designed using the Harris 8038 integrated circuit. These circuits create an analog sine-wave output with a variable amplitude control and a digital CMOS output. The analog amplitude is controlled with a resistive potentiometer labeled "Amplitude" on the Lab Module. Turning the potentiometer to a minimum does bring the output to zero. The highest range has enough gain to cause some clipping of the output voltage. Frequency of this part is controlled with another resistive potentiometer.

Receiver

The receiver uses 1/4 of a quad operational amplifier in a transimpedance mode to convert the input current from the photodiode to a voltage. The photodiode is an Industrial Fiber Optics part number IF-D91. A resistive potentiometer in the feedback path of transimpedance controls the transimpedance gain. The operational is biased with a resistor network to operate in the middle of its active region.

The output of the transimpedance amplifier is connected to the analog and digital signal conditioning circuits. It is AC-coupled to an LM386 audio amplifier with a gain of 20, which can be used to drive loads down to 8 ohms, such as the speaker. The DC output of this stage is normally at 6 volts, which is one-half of the 12-volt supply voltage. Do not use the LM386 to drive a low impedance load without capacitively coupling, as the heavy current drain may overload the LM386 and damage it.

The transimpedance amplifier is also connected to a digital Schmitt trigger which is CMOS- and TTL-compatible with outputs at 0 to +12 volts. Red and green indicator LEDs, for low and high digital signal levels, are located just above the digital Schmitt trigger.

Speaker

The speaker is located below the grid pattern on front of lab module and is a standard 8-ohm impedance speaker. This one has a Mylar[®] film for durability and extended frequency response.

Input Jacks

The input jacks on the module are an industry-standard banana. They are color-coded with the test leads to minimize possible mistakes when configuring the demonstrations and experiments.

WIRE TEST LEADS

This training system contains six banana-to-banana wire test leads with color-coding on both ends to help students through the demonstrations. There are, however, a few exceptions in which the colored plugs of the leads and jacks on the module will not match when in use. These exceptions are noted in the step-by-step instructions. The test leads which were shipped with the Demonstration System, and required for operation, are:

- 4 6-inch leads with a yellow banana plug on one end and orange banana plug on the other.
- 2 7-inch leads with brown banana plugs on both ends.

Both the 6-inch and 7-inch leads use standard 18-gauge test lead wire.

AUDIO INTERFACE LEADS

Two special purpose audio interface cables are included with each system. They feature a standard connections specially wired for connecting standard audio interfaces to this fiber optic training system. One end is the standard 3.5 mm earphone jack. Exiting the 3.5 mm jack are positive and negative electrical leads. The negative connection is the black wire terminating in a black male tip plug. This lead is connected to the negative (Ground) terminal of the power supply when the module is operating. The other connection is a

white wire terminating in a male banana connector. One of these cables has a brown banana jack on the end and the other a yellow banana jack on the end. Functionally they are the same, but they are color-coded to help students in the procedures herein.

POWER ADAPTERS

This module uses power adapters to reduce 120 volts AC to 12 volts DC. The connector of the adapter plugs into the black plastic receptacle located on the left side of the module, above the Speaker. Most 12-volt or greater DC power supplies with 500 current capacity will operate the Lab Modules if the connectors are of the right type. Do not use AC output power adapters, or those above 20 volts DC because this will cause damage to equipment.

If this module was shipped outside North America, you may find your adapters to be 220 VAC input. If you find that you have voltage adapters that are not suitable for the voltages or electrical receptacles in your region, please contact us for remedy.

GLASS FIBER

In the Industrial Fiber Optics ' glass version of the Fiber Optic Demonstraion System are 7 individual optical fibers:

- 1 1-meter glass optical fiber with orange jacket
- 1 3-meter glass optical fiber with gray jacket
- 1 3-meter glass optical fiber with orange jacket
- 1 10-meter glass duplex optical fiber with orange jacket
- 1 1-meter 1000 μm core optical fiber with black jacket
- 1 3-meter 1000 μm core optical fiber with black jacket
- 1 10-meter 1000 μm core optical fiber with black jacket

The 62.5/125 micron fibers are graded index optical fibers with ST connectors on both ends. Both the fiber and the connectors are industry standards within the fiber optic community. The different colored fibers jacket is a convenience to assist in routing the fibers. A duplex fiber is used for the longer fibers, rather than two separate jacketed fibers, for neater and easier to setups. The duplex fiber has a white or blue marking on the one fiber's jacket to help in identification.

The 1000 μm core diameter fibers have been included in this training curriculum because the large core has some special functions that the small 62.5 μm core does not have. These features include transmitting greater optical power in sensor applications, greater attenuation, and more susceptible to bending losses.

REFERENCES

Following is a list of books, magazines, and other items that may be useful in the study of fiber optics. If the title does not mention fiber optics, please still consider it a worthwhile source of information, since fiber optic systems span a number of technologies.

Books

Introductory

Optoelectronics, Fiber Optics, and Laser Cookbook, Thomas Petruzzellis, McGraw-Hill Publishing, 11 West 19th Street, New York, NY 10011, 1997

Fiber Optics: A Bright New Way to Communicate, Billings and Dodd, Mead & Company, New York, NY 1986

The Rewiring of America: The Fiber Revolution, David Chaffee, Academic Press, Inc., 1250 Sixth Avenue, San Diego, CA 92101, 1988

Understanding Fiber Optics, Second Edition, Hecht, Prentice-Hall, Inc., 1 Lake Street, Upper Saddle River, NJ 07458, 1997

Fiber Optics Communications, Experiments & Projects, Waldo Boyd, Howard W. Sams Publishing, 4300 West 62nd Street, Indianapolis, IN 1982

Technicians Guide to Fiber Optics, Sterling, AMP Incorporated, Harrisburg, PA 17105, 1987 (Paperback), ITP Education Group, Box 95971, Chicago, IL 60694 (Hardbound version)

Fiber Optics Handbook, Second Edition, Christian Hentschel, Hewlett Packard, 3000 Hanover Street, Palo Alto, CA 94304, 1988

Advanced

Fiber Optic Communications, Fourth Edition, Joseph Palais, Prentice-Hall Inc., 1 Lake Street, Upper Saddle River, NJ 07458, 1998

Photonics Rules of Thumb: Optics, Electro-Optics, Fiber Optics, & Lasers, John Lester Miller, Edward Friedman, McGraw-Hill Publishing, 11 West 19th Street, New York, NY 10011, 1996

Optical Fiber Transmission, E. E. Basch, Howard W. Sams Publishing, 4300 West 62nd Street, Indianapolis, IN, 1986

Fiber Optic Test & Measurement, Dennis Derickson, Prentice-Hall Inc., 1 Lake Street, Upper Saddle River, NJ 07458, 1997

The Fiber Optic Cable Installation/Repair, Erik R. Pearson, ITP Education Group, Box 95971, Chicago, IL 60694 1997

College Level

An Introduction to Optical Fibers, Cherin, McGraw-Hill Publishing, 11 West 19th Street, New York, NY 10011, 1983

Fiber Optic Handbook for Engineers and Scientists, Allard, McGraw-Hill Publishing, 11 West 19th Street, New York, NY 10011, 1990

Plastic Optical Fibers, Club Des Fibres Optiques Plast, John Wiley & Sons, Inc., 605 Third Avenue, New York, NY 10158-0012, 1996

Fibre Optics: Theory & Applications, Serge Ungar, John Wiley & Sons, Inc., 605 Third Avenue, New York, NY 10158-0012, 1991

Fiber Optics in Communication Systems, Elion and Elion, Marcel Dekker, Inc., 270 Madison Avenue, New York, NY 10016-0602, 1978

Pulse Code Formats for Fiber Optic Communications, Morris, Marcel Dekker, Inc., 270 Madison Avenue, New York, NY 10016-0602, 1983

Fiber Optic Smart Structures, Eric Udd, John Wiley & Sons, Inc., 605 Third Avenue, New York, NY 10158-0012, 1995

Fiber Optics, Hoss and Lacy, Prentice-Hall, Inc., 1 Lake Street, Upper Saddle River, NJ 07458, 1993

Semiconductor Devices for Optical Communications, Kressel, Springer-Verlag, Inc., 175 5th Avenue, New York, NY 10010, 1980

Semiconductor Laser and Heterojunction LEDs, Butler and Kressel, Academic Press, Inc., 1250 Sixth Avenue, San Diego, CA 92101, 1977

Lasers & Optical Fibers in Medicine, Abraham Katzir, Academic Press, Inc., 1250 Sixth Avenue, San Diego, CA 92101, 1993

Fundamentals of Optical Fibers, John A. Buck, John Wiley & Sons, Inc., 605 Third Avenue, New York, NY 10158-0012, 1995

Fiber Optic Reference Guide: A Practical Guide to the Technology, David R. Goff, Butterworth, 225 Wildwood Avenue, Ste. B, Woburn, MA 01801, 1996

Erbium-Doped Fiber Amplifiers: Principles & Applications, Emmanuel Desurvive, John Wiley & Sons, Inc., 605 Third Avenue, New York, NY 10158-0012, 1994

Erbium Fiber Amplifiers, P. Becker, J.R. Simpson, N. Olsson, Academic Press, Inc., 1250 Sixth Avenue, San Diego, CA 92101, 1997

Other

Laser Receivers, Ross, John Wiley & Sons, Inc., 605 Third Avenue, New York, NY 10158-0012, 1966

Noise in Electronic Circuits, Ott, John Wiley & Sons, Inc., 605 Third Avenue, New York, NY 10158-0012, 1976

Fiber-Optic Systems: In Introduction & Business Overview, Terry Edwards, John Wiley & Sons, Inc., 605 Third Avenue, New York, NY 10158-0012, 1989

Fiber Optics Standard Dictionary, 3/E, Martin H. Weik, Chapman & Hall, 115 Fifth Avenue, New York, NY 10003, 1997

SAFETY

Safety with Lasers and Other Optical Sources, Stiney and Wolbarsht, Plenum Publishing Company, 233 Spring Street, New York NY 10013-1578 1980

Safe Use of Lasers, ANSI Standard Z136.1, 1993, Laser Institute of America, 12424 Research Parkway, Suite 125, Orlando, FL 32826

Safe Use of Optical Fiber Communications Systems Utilizing Laser Diodes & LED Sources, ANSI Standard Z136.2, 1997, Laser Institute of America, 12424 Research Parkway, Suite 125, Orlando, FL 32826

Laser and Eye Safety in the Laboratory, Garcia and Mathews, IEEE Press, 445 Hoes Lane, P.O. Box 1331, Piscataway, NJ 08855-1331

MONTHLY PUBLICATIONS

The first two items are journals that are available as members of the respective professional societies. The last four are trade magazines available free of charge to qualified readers.

Applied Optics, Optical Society of America, 1816 Jefferson Place, NW, Washington, DC 20036

Optical Engineering, SPIE, P. O. Box 10, Bellingham, WA 98227-0010

Fiberoptic Product News, Gordon Publications, Inc., 301 Gibraltar Drive, Box 650, Morris Plains, NJ 07950-0650

Laser Focus World, PenWell/ATD, Ten Tara Blvd., Fifth Floor, Nashu, NH 03062-2801

Lightwave Magazine, PenWell/ATD, Ten Tara Blvd., Fifth Floor, Nashu, NH 03062-2801

www.light-wave.com

Photonics Spectra, Laurin Publishing Co., Berkshire Common, 2 South Street, P.O. Box 4949, Pittsfield, PA 01202-4849

BUYER'S GUIDES

Fiberoptic Product News Buying Guide, Gordon Publications, Inc., 301 Gibraltar Drive, Box 650, Morris Plains, NJ 07950-0650

Lightwave Buyer's Guide, PenWell/ATD, Ten Tara Blvd., Fifth Floor, Nashu, NH 03062-2801

Photonics Spectra Buyer's Guide, Laurin Publishing Co., Berkshire Common, 2 South Street, P.O. Box 4949, Pittsfield, PA 01202-4949

ORGANIZATIONS

Optical Society of America, 1816 Jefferson Place, NW., Washington, DC 20036

Society of Photo-Optical Instrumentation Engineers (SPIE), P. O. Box 10, Bellingham, WA 98227-0010

Laser Institute of America, 12424 Research Parkway, Suite 125, Orlando, FL 32826

GLOSSARY

This glossary contains definitions and descriptions which are intended to help everyone understand the meanings of the words as they are used in this manual, and related to electronics, fiber optics, and lasers. Many words have several shades of meaning, or even totally different meanings, when used within other contexts. These definitions should be adequate for understanding this field and using this laboratory guide.

A

ABSORPTION - In an optical fiber, the loss of optical power resulting from conversion of that power into heat. See also "Scattering."

ACCEPTANCE ANGLE - The angle within which a fiber will accept light for transmission along its core. This angle is measured from the centerline of the core.

ANALOG - An electrical signal which varies continuously. Sound waves and ocean surf repeatedly striking the beach are examples of analog signals. Analog signals have a frequency range (bandwidth) measured in Hertz (Hz). (See definition of "Digital" below in glossary.)

ANGLE OF INCIDENCE - The angle formed between an incoming ray of light striking a surface and a perpendicular line drawn to that surface at the point of incidence (the point at which the ray strikes the surface.)

ANGLE OF REFLECTION - The angle formed between an outgoing ray of light after striking a surface, and reflecting from it, and a perpendicular line drawn to that surface at the point of incidence.

ANGSTROM (Å) - A unit of length, 0.1 nm or 10^{-10} meters, often used to measure wavelength but not part of the SI system of units. Often written out as Angstrom(s) because the special symbol Å is not available.

ANODE - The element of an electron tube or semiconductor device towards which the primary electron stream flows. It can be thought of as the positive potential terminal.

ATTENUATION - The weakening or loss of an electric signal or optical power, usually directly related to distance traveled (the farther a signal travels, the weaker it gets, unless amplified along the way). Attenuation is often measured in *decibels* (a common measurement unit for loudness) per kilometer.

AVALANCHE PHOTODIODE (APD) - A semiconductor photodetector that includes detection and amplification stages. Electrons generated at a p-n junction are accelerated in a region where they free an avalanche of other electrons. APDs can detect faint signals, but require higher voltages than other semiconductor detectors.

B

BANDWIDTH - The width of a band of frequencies used for a particular purpose. Thus the bandwidth of a television station is 6 MHz.

BUFFER - See Fiber Buffer.

C

CABLE - A single fiber or a bundle, including strengthening strands of opaque material, if used, covered by a protective jacket.

CATHODE - The element of an electron tube or semiconductor device from which the primary electron stream flows. It can be thought of as the negative potential.

CLADDING - The layer of glass or other transparent material surrounding the light-carrying core of an optical fiber. It has a lower refractive index than the core. Coatings may be applied over the cladding.

COAXIAL - Having the same centerline. A cross-section of coaxial cable would reveal concentric circles, each with the same center point.

COHERENT - Signals, at whatever frequency, that are at the same frequency and in phase with each other, as within a laser beam.

COLLIMATED - Light rays, within a light beam, that are parallel with each other, as within a laser beam.

CONNECTOR - A device that mounts at the end of a fiber optic cable, light source, receiver or housing, that mates to a similar device to couple light optically into and out of optical fibers. A connector joins two fiber ends or one fiber end and a light source or detector.

CORE - The central portion of an optical fiber that carries the light.

COUPLER - A device which connects three or more fiber ends, dividing one input between two or more outputs or combining two or more inputs into one output.

COUPLING LOSS - The amount of power in the fiber optic link lost at discrete junctions such as source-to-fiber, fiber-to-fiber, or fiber-to-detector.

CRITICAL ANGLE - The angle of incidence in which light can no longer leave the material in which it is traveling, to enter another medium or undergoes total internal reflection. This special condition occurs only when the second material has a lower refractive index than the first material.

D

DARK CURRENT - The parasitic output current that a photodetector produces in the absence of light.

DECIBEL (dB) - A logarithmic unit of measure, based upon the ratio of the output power to the input power. Ten times the base-ten logarithm of the ratio of the two power levels.

DEMODULATOR - A device which removes an information signal from a carrier wave. The information signal is a temporary add-on, such as a long-distance telephone conversation. The signal may be added to laser light in an optic fiber, transmitted to its destination, and then removed and translated back into sound when it reaches its intended listener.

DEPLETION REGION - The portion of a semiconductor device that has no charge carriers.

DETECTOR - A device that generates an electrical signal when illuminated by some stimuli. The most common in fiber optics are photodiodes, avalanche photodiodes, photodarlington and phototransistors.

DIFFUSE REFLECTION - Reflection from a surface that makes it appear matte or dull. Opposite of the specular reflection occurring from a mirror.

DIGITAL - Refers to the transmission of a signal, using the *binary* form. The binary system can be thought of as an “off/on” systems, in which an “off” is represented by a zero (0) and an “on” by the numeral 1. An example of a digital appliance is a toaster. It is either on or off. (See the definition of “Analog” above.)

DIODE - An electronic device that lets current flow in only one direction.

DIODE LASER - A solid-state semiconductor device consisting of at least one P-N junction, capable of emitting coherent radiation under specific conditions.

DISCRETE - A individual component has one operation or function in itself. Examples of such are: resistors, capacitors, LEDs.

DISPERSION - The spreading out of light pulses as they travel in an optical fiber, proportional to length.

DISTORTION - The changing of a signals wave shape. Examples of distortion include dispersion and clipping in an amplifier circuit.

DUPLEX - Dual. As it relates to fiber optics it is a fiber-optic cable containing two fibers.

E

ELECTROMAGNETIC WAVES - One form that radiant energy can assume as it travels through space. Electromagnetic waves include radio waves, gamma rays, X-rays, infrared, ultraviolet and visible light. All electromagnetic waves have an electrical component and a magnetic component. As the waves move forward, they also travel up and down in “mountains and valleys” (crests and troughs) which are perpendicular to the forward direction of travel. (Also note the definition of “Wave-Particle Duality Theory” in this glossary.)

ELECTRON - A particle which orbits the nucleus of an atom. Electrons contain a tiny negative electrical charge of 1.6×10^{-19} coulombs.

ENDOSCOPE - A fiber-optic bundle that delivers light and views inside the human body.

F

FALL TIME - The time it takes an output to fall from a high level to minimum value, typically measured as the time to fall from 90% to 10% of minimum output.

FIBER - The optical waveguide, or light-carrying core or conductor. See also Core and Cladding.

FIBER BUFFER - A material that is used to protect an optical fiber from physical damage, providing mechanical isolation, and/or protection.

FIBER BUNDLE - An assembly of unbuffered fibers. These are usually used as single transmission channel to transmit light or images which may be coherent or incoherent.

FIBER OPTICS - A branch of optical technology that deals with the transmission of radiant energy through optical waveguides made of glass or plastic.

FRESNEL REFLECTION - The reflection losses that occur at the input and output surfaces of any optical material due to the differences in refractive indexes between them.

G

GRADED-INDEX FIBER - An optical fiber which has a gradual refractive index change from the center to the edge. This type of fiber has much less optical dispersion than step-index fiber.

H

HERTZ (Hz) - A unit of frequency equivalent to one cycle per second.

I

INCOHERENT LIGHT - Light that is made up of rays that lack a fixed phase relationship. In fiber optics, LED's produce this type of radiation.

INDEX OF REFRACTION - See Refractive Index.

INFRARED LIGHT - Light with wavelengths longer than 750 nanometers and shorter than 1 millimeter. Infrared radiation cannot be seen, but it can be felt as heat.

INFRARED-EMITTING DIODE (IRED) - A semiconductor diode that is very similar to LEDs which emits infrared radiation instead of visible. The manufacturing methods are also similar, but they are composed of different materials.

J

JACKET - A layer of material surrounding a fiber but not bonded to it.

JOULES - A standard unit of measure for energy. Named for British physicist James P. Joule.

K

KILO - A prefix in the SI system meaning one thousand (1×10^3). Abbreviation k.

L

LASER - An acronym for "Light Amplification by Stimulated Emission of Radiation." Light that is highly directional, covers a very narrow band of wavelengths and is more coherent than ordinary light. In fiber optics, the most important sources of laser energy are semiconductor laser diodes.

LED - Light Emitting Diode.

LIGHT - Electromagnetic radiation visible to the human eye. Commonly, the term is applied to electromagnetic radiation with properties similar to visible light, including the invisible near-infrared radiation used in fiber optic systems.

LIGHT EMITTING DIODE (LED) - A P-N junction semiconductor device that emits incoherent optical radiation when biased in the forward direction.

M

MEGA - A prefix in the SI system meaning one million (1×10^6). Abbreviation, M.

MICRO - A prefix in the SI system meaning one millionth (1×10^{-6}). Abbreviation, μ .

MICROMETER - A unit of length in the SI system equal to 10^{-6} meters. Abbreviation μm .

MILLI - A prefix in the SI system meaning one thousandth (1×10^{-3}). Abbreviation, m.

MODULATE - To modify a single-frequency “carrier frequency” by adding or superimposing on that frequency a signal containing information. This is the way in which information (music and words) is added to radio waves, and it is the way that long-distance telephone conversations are added to laser light being transmitted through optic fibers. Modulation converts words into impulses of light that can be “translated” back into words when the signal reaches its destination.

MULTIMODE FIBER - Optical fibers with relatively large core diameters compared to single-mode fibers. The core diameter of multimode fibers can range from 25-200 microns.

N

n - A symbol used to represent refractive index.

NANOMETER - One millionth of a millimeter. A common unit of measure for the wavelengths of high-frequency energy such as light. Abbreviated nm.

NEAR-INFRARED - The shortest wavelengths of infrared region, just a little longer wavelengths than the visible.

NORMAL - Also referred to as *line normal*. An imaginary line that forms a right angle with a surface or with other lines. The word “normal” is often used rather than “perpendicular” when measuring/describing incident, reflected and refractive angles.

NUMERICAL APERTURE (NA) - The numerical aperture of an optical fiber defines the characteristic of the fiber in terms of its acceptance of impinging light. The larger the numerical aperture the larger the "openness" to which a fiber will accept light.

O

OPTICAL SPECTRUM - The electromagnetic spectrum in the wavelength region from 10 nm (ultraviolet) to 1000 μm (far-infrared).

OPTOELECTRONICS - The field of electronics which deals with lasers, photodetectors, light-emitting-diodes and other electronic devices which respond to, or produce optical radiation.

P

PHASE - A term used to define the relationship between two identical electromagnetic waves that are shifted a portion of a wavelength apart. Phase, frequency and amplitude all categorize different aspects of electromagnetic waves.

PHOTODARLINGTON - A light detector in which a phototransistor is combined in a device with a second transistor to amplify its output current.

PHOTODETECTOR - A detector that responds to incident light upon its surface. See Also: Photodarlington, Phototransistor, PIN Diode

PHOTON - The fixed quantum elemental unit of light energy. Photons, when viewed as particles of light, are one of two ways we can explain the properties and behavior of light (See "Wave-Particle Duality Theory" below.)

PHOTOTRANSISTOR - A transistor that detects light and amplifies the resulting electrical signal. Light falling on the base-emitter junction generates a current, which is amplified internally.

PIN DIODE - A semiconductor detector with an intrinsic region separating the P- and N-doped regions. This design gives fast, linear response and is widely used in fiber-optic receivers.

PLANCK'S CONSTANT - A universal constant (h) which gives the ratio of a quantum of radiant energy (E) to the frequency (ν) of its source. It is expressed as $E = h\nu$. Named after German Physicist Max K. E. Planck. Its value is $6,625 \times 10^{-34}$ joule-second.

PROPAGATING - Transmitting energy or moving the energy along a path.

Q

R

RECEIVER - A device that detects an optical signal and converts it into an electrical form usable by other devices. See also: Transmitter.

REFRACTIVE INDEX - The ratio of the speed of light in a vacuum to the speed of light in a material. Abbreviated **n**.

RESPONSIVITY - The ratio of detector output to input, usually measured in units of amperes per watt (or microamperes per microwatt).

RISE TIME - The time it takes an output to rise from a low level to peak value. Typically measured as the time to rise from 10% to 90% of maximum value.

S

SCATTERING - The changes in direction of light confined within an optical fiber occurring due to imperfections in the core and cladding.

SPECTRUM - A band of continuous frequencies or wavelengths; also the visible separation of the colors contained in white light.

STEP-INDEX FIBER - A fiber in which the refractive index changes abruptly at the boundary between core and cladding.

T

TOTAL INTERNAL REFLECTION - The total reflection of light back into a material when it strikes a boundary at an angle exceeding the critical angle. This is what keeps light confined internally to an optical fiber. (See "Critical Angle".)

TRANSDUCER - A device designed to convert one form of energy into another. For example, a speaker converts audio-frequency electrical energy into audible sound; a phonograph cartridge converts mechanical movement of the needle into an electrical signal.

TRANSMITTER - A device (or transducer) that converts an electrical signal into an optical signal for transmission on a fiber cable. See also: Receiver.

U

ULTRAVIOLET - An invisible portion of the optical spectrum whose wavelengths begin immediately beyond the violet end of the visible spectrum. Ultraviolet wavelengths range

from approximately 20 to 380 nm. Also the most damaging of the sun's rays to the skin and eyes.

V

VELOCITY OF LIGHT - The speed of light in a vacuum, in round numbers, is 300,000 kilometers per second, or 186,000 miles per second. It is less than .01 % slower in air.

W

WAVE PARTICLE DUALITY THEORY - A theory in modern physics which maintains that the properties of light can best be explained by sometimes treating light as particles (a stream of photons), and sometimes as electromagnetic waves.

WAVELENGTH - The distance an electromagnetic wave travels in the time it takes to oscillate through a complete cycle. Wavelengths of light are measured in nanometers or micrometers.

X

Y

Z

FINAL TEST

Student: _____

1. Which two of these optic receiver parts are most critical to operation? (Circle the correct answers.)
 - a) Main Amplifier
 - b) Signal Processor
 - c) Preamplifier
 - d) Photodetector

2. The following items can be found in fiber optic cables.
 - a) Buffer
 - b) Cladding
 - c) Strength members
 - d) Core
 - e) Jacket
 - f) All of the above
 - g) None of the above
 - h) a and e

3. Fiber optics is best known for its application in long-distance telecommunications.
 - a) True
 - b) False

4. To link fiber optic components, which items are used?
 - a) Electrons
 - b) Protons
 - c) Splices
 - d) Cosmonauts
 - e) Connectors
 - f) None of the above
 - g) c and e

5. A fiber optic cable can carry how many telephone calls as compared to conventional copper wire:
 - a) 1
 - b) 10
 - c) 25
 - d) 100
 - e) >1000

6. An optical repeater:
 - a) Is useful for analog and digital formats
 - b) Has high bandwidth capabilities
 - c) Can amplify multiple wavelengths
 - d) Has the potential of low cost
 - e) All of the above

7. To permanently link two optical fibers one would use a:
 - a) Glue gun
 - b) Connector
 - c) Splice
 - d) b and c
 - e) All of the above

8. The basic particle of light is:
 - a) An electron
 - b) A positron
 - c) A photon
 - d) A neutron
 - e) A quark

9. Lasers are too dangerous to be used in fiber optics.
 - a) True
 - b) False

10. Silicon is the most commonly used detector material in fiber optic applications for wavelengths between 400 and 1050 nm.
 - a) True
 - b) False

11. Light diverges when it leaves the end of an optical fiber.
 - a) True
 - b) False

12. Optical fibers are never used in sensor applications.
 - a) True
 - b) False

13. The replacement of copper wiring harnesses with fiber optic cabling increases the weight of an aircraft
 - a) True
 - b) False

14. The “two personalities” of light can be represented either as electromagnetic waves or particles/photons.
a) True
b) False
15. Light is a small part of the electromagnetic spectrum.
a) True
b) False
16. The longer the wavelength of light, the higher its frequency.
a) True
b) False
17. One of the most important optical measurements of any transparent material is its refractive index.
a) True
b) False
18. The speed of light in a glass is 3×10^9 meter per second.
a) True
b) False
19. Circle the two most common materials of which optical fibers are made:
a) Diamond
b) Gallium Nitrate
c) Gallium aluminum phosphide
d) Hair
e) Flint
f) Glass
g) Plastic
h) Teflon
20. The principle called total internal reflection explains why light is guided in an optical fiber.
a) True
b) False
21. Fiber optic couplers are available in different configurations.
a) True
b) False

22. Fiber end finishes are important for operation of a fiber optic system.
- a) True
 - b) False
23. Plastic optical fiber has less attenuation, or greater transmission, than glass fiber.
- a) True
 - b) False
24. When light passes from one material to another with a different refractive index, bending of the light rays occurs. This phenomenon was first mathematically described by:
- a) Fred Fresnel
 - b) Howard Maxwell
 - c) Willebrord Snell
 - d) Galilei Galileo
25. LEDs can be made from the same semiconductor materials as laser diodes.
- a) True
 - b) False
26. What do the letters in the acronym **LED** stand for?
- a) Laser emission by defect
 - b) Light emission by diodes
 - c) Light emitting device
 - d) Light emitting diode
27. Information (data) is transmitted over optical fiber by means of:
- a) Light
 - b) Acoustic waves
 - c) Radio waves
 - d) Cosmic rays
 - e) None of the above
28. Which is a modern-day application of fiber optic illumination?
- a) Borescopes
 - b) Intersection “Walk” and “Wait” signs
 - c) Microscope specimen lighting
 - d) All of the above

29. Circle the three basic components in a fiber optic communications system.
- a) Telescope
 - b) Transmitter
 - c) Receiver
 - d) Surveillance satellites
 - e) Maser fiber
 - f) Optical fiber
 - g) Alternator
30. Fiber end finishes are important for operation of a fiber optic system.
- a) True
 - b) False

Pretest

Answer Sheet

1. What do the letters in the acronym **LED** stand for?
 - a) Laser emission by defect
 - b) Light emission by diodes
 - c) Light emitting device
 - d) **Light emitting diode**
2. When light passes from one material to another with a different refractive index, bending of the light rays occurs. This phenomenon was first mathematically described by:
 - a) Howard Maxwell
 - b) Galilei Galileo
 - c) Fred Fresnel
 - d) **Willebrord Snell**
3. Fiber optics is best known for its application in long-distance telecommunications.
 - a) **True**
 - b) False
4. Circle the three basic components in a fiber optic communications system.
 - a) Telescope
 - b) **Transmitter**
 - c) **Receiver**
 - d) Surveillance satellites
 - e) Maser fiber
 - f) **Optical fiber**
 - g) Alternator
5. Information (data) is transmitted over optical fiber by means of:
 - a) **Light**
 - b) Radio waves
 - c) Cosmic rays
 - d) Acoustic waves
6. Which is a modern-day application of fiber optic illumination?
 - a) Borescopes
 - b) Intersection "Walk" and "Wait" signs
 - c) Microscope specimen lighting
 - d) **All of the above**

7. What type of materials can be used as a lasing medium?
- a) Solid
 - b) Liquid
 - c) Gas
 - d) **All of the above**
8. The basic particle of light is:
- a) **A photon**
 - b) A quark
 - c) An electron
 - d) A neutron
 - e) A positron
9. Lasers are too dangerous to be used in fiber optics.
- a) True
 - b) **False**
10. Silicon is the most commonly used detector material in fiber optic applications for wavelengths between 400 and 1050 nm.
- a) **True**
 - b) False
11. List two advantages of using optical fiber.
- Light in weight*
- No electromagnetic waves transmitted*
12. Planck's Constant has been a tremendous benefit to the timber and wooden shipbuilding industries.
- a) True
 - b) **False**
13. The replacement of copper wiring harnesses with fiber optic cabling increases the weight of an aircraft.
- a) True
 - b) **False**
14. The "two personalities" of light can be represented either as electromagnetic waves or particles/photons.
- a) **True**
 - b) False

15. Light is a small part of the electromagnetic spectrum.
a) **True**
b) False
16. The shorter the wavelength of light, the higher its frequency.
a) **True**
b) False
17. One of the most important optical measurements of any optical material is its refractive index.
a) **True**
b) False
18. The speed of light in a vacuum is approximately 3×10^8 meter per second.
a) **True**
b) False
19. Circle the two most common materials of which optical fibers are made:
a) **Plastic**
b) Sodium chloride
c) Gallium aluminum phosphide
d) **Glass**
e) Flint
f) Hair
g) Diamond
20. The principle called total internal reflection explains why light cannot be guided in an optical fiber.
a) True
b) **False**

Worksheet #1

Answer Sheet

1. The use of fiber optic materials does not decrease weight or size in aircraft.
 - a) True
 - b) **False**

2. List three applications of fiber optics:
Communications _____
Computers _____
Sensing device _____

3. Fiber optic cabling is being installed:
 - a) As replacement for copper telephone lines
 - b) Underground
 - c) In buildings
 - d) **All of the above**

4. Early optical systems were dependent upon:
 - a) Weather conditions
 - b) Line of sight
 - c) Time of day
 - d) **All of the above**

5. Light is a form of energy.
 - a) **True**
 - b) False
 - c) Sometimes
 - d) Rarely

6. Light, in the fiber optics vocabulary, means electromagnetic radiation or energy in the wavelength range including infrared, visible and ultraviolet.
 - a) **True**
 - b) False

7. Wavelength of light is:
- a) $= \frac{c}{f}$ **correct answer**
 - b) $= \frac{f}{c}$
 - c) $= c \cdot f$
 - d) $= a \cdot b$
8. Total internal reflection is the fundamental principle that keeps light confined in an optical fiber.
- a) **True**
 - b) False
9. Circle the two materials that are used in optical fibers.
- a) **Plastic**
 - b) Uranium
 - c) **Glass**
 - d) Silicon
 - e) Carbon
10. The two most common light sources for fiber optics are:
- a) **Lasers**
 - b) Flares
 - c) **LEDs**
 - d) Incandescent bulbs

Worksheet #2

Answer Sheet

- Optical communication dates back to:
 - 1060 B.C.
 - 1790 B.C.
 - 1790 A.D.**
 - 1492 O.D.
- The optical telegraph replaced the electrical telegraph because it could operate at night.
 - True
 - False**
- The invention of the *light emitting diode (LED)* was one of the key elements making fiber optic communications possible today.
- When did the Bell System's first trial of a fiber optic communications network occur?
 - 1960s
 - 1070s
 - 1970s**
 - 1990s
- Fiber optics can be used to transmit information very reliably.
 - True**
 - False

- Did you find it hard to identify a person's voice at the other location in **Lab Demonstration #2**? If so, describe why.

No. The transmitter on Module 1 and receiver on Module 2 had adequate frequency and amplitude range to reproduce voice sounds without distortion, similar to a telephone.

- Do some sounds or voices transmit better than others? If so, identify them.

All sounds should transmit the same.

- Do any musical instrument tones not transmit through this fiber optic system? If so, describe why.

All musical instrument sounds will be transmitted through the fiber equally well. Any "deficient" sounds are the result of poor speaker material quality. Limitations on sound quality and frequency of this fiber link will be by the speaker.

Worksheet #3

Answer Sheet

1. Name at least three main areas of application for fiber optics.

Telecommunications

Microscope lighting

Endoscopes

Signs

Light indicators

Sensors

Computers and local area networks

2. Telecommunications networks do not use any fiber optics components.

a) True

a) **False**

3. The computer and local area network applications of fiber optics have been limited by the **cost** of the fiber optic components.

4. Fiber optics has been used for **auxiliary** lighting in microscopes.

5. **Plastic** optical fiber will most likely be used in automobiles of the future.

6. Automobiles demand very large temperature range capabilities for their optical cabling, ranging from - 40 degrees up to + **150** degrees Centigrade.

7. Replacement of copper wiring harnesses with fiber optics cabling decreases the weight of an aircraft.

a) **True**

b) False

8. Name one benefit to airplanes of installing fiber optics in them.

Reduced weight, extended range, increased fuel load, unaffected by or reduced radiation of electronic signals.

9. The use of fiber optics and/or lasers is not allowed in surgical procedures or hospitals.

a) True

b) **False**

10. Fiber optic **sensors** detect pressure, temperature, rotation and other physical characteristics.

11. Did you find it easy to master transmitting dots and dashes? Are your dots and dashes all uniform?

No. Learning to transmit consistent dots and dashes takes lots of practice.

12. Did you find that everybody's dots and dashes were the same?

No. Everyone's perception of how long a "dot" or a "dash" will be different.

13. Is it clear when transmitting Morse Code when one word stops and another word starts?

Not always. Morse Code is very rapid, so one word may not stop before another starts (unless it is understood that there will be some time interval between words).

14. Would you agree it is much easier for machines (for example, computers) to interpret dashes and dots and convert them to something more readily understood?

Yes. Machines and computers can interpret signals that are either "on" or "off" quicker and more consistently than humans.

15. How long does it take after you press the Momentary Switch at Location 1 for a sound to be produced from the Speaker at Location 1?

Sound is produced almost instantaneously after pushing the switch. No delay can be perceived by human.

16. When you vary the frequency on the Signal Generator at Location 1 how does the sound from the Speaker at Location 1 change? (Repeat Step 10 if necessary.) Explain your result.

As you turn the Signal Generator knob clockwise the sound will increase in pitch or frequency. As you turn the knob counter clockwise the sound will decrease in pitch. The sound coming from the Speaker is an audio reproduction of what is being generated by the Signal Generator, transmitted over an optic fiber. Since the Frequency Control Knob controls the Signal Generator frequency, the sound should change accordingly.

17. How does the sound level from the Speaker at Location 1 change when you change the amplitude of the Signal Generator?

Changing the amplitude of the Signal Generator will have no effect on the sound level from the Speaker at Location 1 because the "amplitude" knob controls the analog signal, not the digital signal.

18. What happens to the sound from Location 1's Speaker when the **Momentary Switch** at Location 1 is closed and the power adapter at Location 2 is disconnected? Did Location 2 receive the signal? How can you tell?

The sound from the Speaker can no longer be heard at Location 1. There is no way to tell if the signal has been received by Location 2 or just was not returned.

19. Did you hear the reflected signal from Location 2 at Location 1's Speaker when its **Momentary Switch** was closed and the fiber was disconnected? Did Location 2 receive the signal? How can you tell?

No. The sound from the Speaker can no longer be heard at Location 1. There is no way to tell if the signal has been received by Location 2.

20. Do you feel that this “handshaking”, or reflection, of transmitted data is a good method of ensuring correct data transmission? Why or why not?

Yes. “Handshaking” is a very good method of ensuring current data transmission because it allows the original sender to compare exactly what message was sent to what was received back. The disadvantage is that in some cases, the returned signal from Location 2 to Location 1 could be garbled or malfunctioning. In this instance, the Operator at Location 1 would resend the information. Although this is time consuming, it is better than not knowing if Location 2 received information correctly.