

Recommended P.C. Board Layout

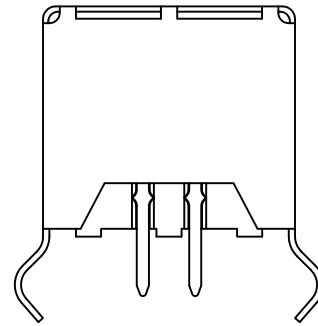
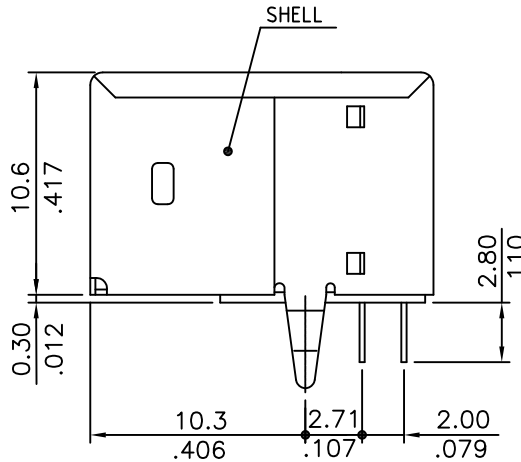
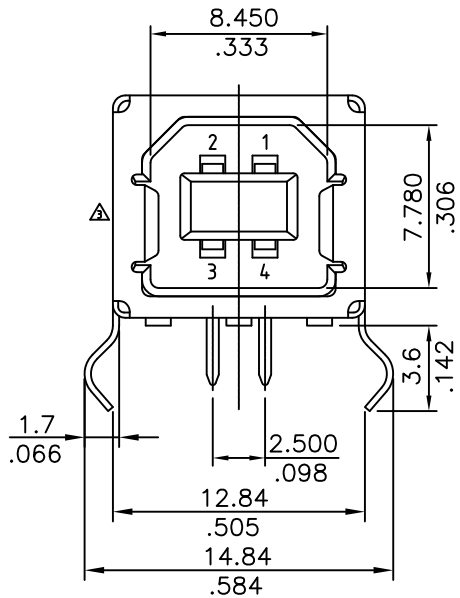

SIGN	DATE	DESCRIPTION	APPROVER
△	2011.02.06	Soldering temperature ratings added. Plating options detailed.	NL
△	2012.10.29	HT plastic info added; USB 2.0 detail added	NL
△	2016.08.22	Modified shell to increase retention force	NL

Material

- Insulator: Glass Filled Polyester
- Flammability: UL94V-0
- Contacts: Phosphor Bronze
- Contact Plating: See options
- Shell: Brass
- Shell Plating: 100u" Min. Tin over 40u" Nickel

Ratings

- Current: 1A
- Voltage: 30V AC(r.m.s.)
- Dielectric Voltage: 750V AC
- Contact Resistance: $-30m\Omega$
- Insulation Resistance: >1,000 MΩ
- Operating Temperature: -0°C ~ +50°C
- △ Hi Temp Plastic: -0°C ~ +85°C

- △ ● Storage Temperature: -20°C ~ +60°C
- Solderability:

- △ ● Resistance to soldering heat:
 - Soldering time 5+/- 0.5 seconds
 - Soldering pot: 245+/- 5°C
- Solderability:
 - Soldering time 5+/- 0.5 seconds
 - Soldering pot: 260+/- 5°C

For Hi Temp plastic option - add H at end of part number

RoHS Compliant

PART NUMBER:

USB-B1HSXX

- COLOR:
 - B: Black
 - W: White
- PLATING:
 - 6: Selective Au Flash/50u" Ni
 - 8: Selective 30u" Au/50u" Ni (USB 2.0)



THESE DRAWINGS AND SPECIFICATIONS ARE THE PROPERTY OF ON-SHORE TECHNOLOGY, INC. AND SHALL NOT BE REPRODUCED, COPIED OR USED IN ANY MANNER WITHOUT THE PRIOR WRITTEN CONSENT OF ON-SHORE TECHNOLOGY, INC.

TITLE		USB - B type, Horizontal, thru hole	
PART NO.	USB-B1HSXX	DWG NO.	USB-B1HSXX.DWG
APPROVED	CHECKED	DESIGNED	DRAWN
Steven 2011.02.06	Marvin 2011.02.06	Marvin 2011.02.06	Marvin 2011.02.06
4050			
		Tolerance	
		UNIT: mm/inches	X° ±1°
SHEET: 01/01		SCALE: NONE	X.XX ±0.30/.012
REV.: A		X.XXX ±0.20/.008	X.XXX ±0.10/.004