

LTC3105EDD: Step-Up DC/DC Converter with Power Point Control and LDO Regulator

DESCRIPTION

Demonstration circuit 1587A is a boost converter optimized for relatively high impedance, very low voltage input power sources. It allows a user to quickly evaluate the LTC3105 boost converter and LDO regulator. Capable of operating with an input voltage as low as 250mV and as high as 5V, the circuit features maximum power point control (MPPC). Jumpers on the circuit board allow the user to select several MPPC voltages, three boost output voltages and three LDO regulator output voltages. Also included are jumpers for shutdown and for selecting an external pull-up voltage for the power good status output. Terminals are provided for input and output connections,

power good output and external power good supply input, shutdown input, and provisions for external MPPC resistor and MPPC diode input.

This demonstration board is especially designed for low power solar cell applications. The LTC3105 data sheet gives a complete description of the part, operation and application information. The data sheet must be read in conjunction with this demo manual.

Design files for this circuit board are available at <http://www.linear.com/demo>

LT, LT, LTC, LTM, Linear Technology and the Linear logo are registered trademarks of Linear Technology Corporation. All other trademarks are the property of their respective owners.

PERFORMANCE SUMMARY (T_A = 25°C)

PARAMETER	CONDITION	VALUE
Start-Up Input Voltage	No Load, R _{MPPC} = 22k, Supply ESR = 0.5Ω, See Section 3	250mV Typical
Input Voltage Range	After Start-Up	0.2V to 5V
Maximum Boost Output Current	V _{IN} = 2V, V _{OUT} = 5V, MPPC = 2V, Resistive Load	125mA
1.8V Boost Output Voltage	V _{IN} = 1.5V, 100Ω Load	1.8V ±3%
3.3V Boost Output Voltage	V _{IN} = 1.5V, 100Ω Load	3.3V ±3%
5V Boost Output Voltage	V _{IN} = 1.5V, 100Ω Load	5V ±3%
1.5V LDO Output Voltage	V _{IN} = 1.5V, 500Ω Load	1.5V ±3%
2.2V LDO Output Voltage	V _{IN} = 1.5V, 500Ω Load	2.2V ±2%
3V LDO Output Voltage	V _{IN} = 1.5V, 500Ω Load	3V ±3%

QUICK START PROCEDURE

Equipment required to evaluate the LTC3105 demonstration circuit include a low voltage bench power supply, digital voltmeters and suitable load resistors. Refer to Figure 1 for proper measurement equipment setup and follow the procedure below.

1. Begin by placing jumpers in the following positions.

JP4 PGOOD	JP1 BOOST	JP3 LDO	JP2 MPPC	JP5 SHDN
VPGOOD	5V	3V	0.4V	OFF

QUICK START PROCEDURE

2. With the power off, connect a low voltage adjustable power supply and three voltmeters as shown in Figure 1 (ammeters are optional). Switch the power supply on and adjust the voltage to approximately 450mV, and move the JP5 jumper to the ON position. With no load resistor on either output, verify that the BOOST and LDO output voltages are within the specifications shown in Table 1. Increase the input voltage to 1.5V and connect suitable load resistors to the output terminals to verify the output voltages under load. The maximum Boost output current is dependant on V_{IN} and the maximum LDO output current is 6mA

Maximum power point control (MPPC) prevents the converter from pulling the input supply voltage down below a preset voltage level when the maximum input supply current is reached. The converter does this by dynamically reducing the converter's output voltage

and current as the input voltage begins to drop due to the input power source current limitations. Without MPPC, a converter would pull the input power source down to near 0V, resulting in near zero output power. MPPC is especially useful with power sources that have relatively high or variable source impedances such as solar cells and other energy harvesting devices. The following exercise is to illustrate the MPPC function.

To demonstrate the MPPC function, place a 10 Ω , 1W resistor in series with the demo board input terminal (V_{IN}) to simulate a high impedance power source. Move jumper JP2 (MPPC) to the 2V position and jumpers JP1 and JP3 to the 5V and 3V positions respectively and connect voltmeters to measure V_{IN} and boost V_{OUT} . With the power supply set to 3.5V, apply voltage to the input. With an adjustable load on the boost output, begin increasing the load on the 5V output.

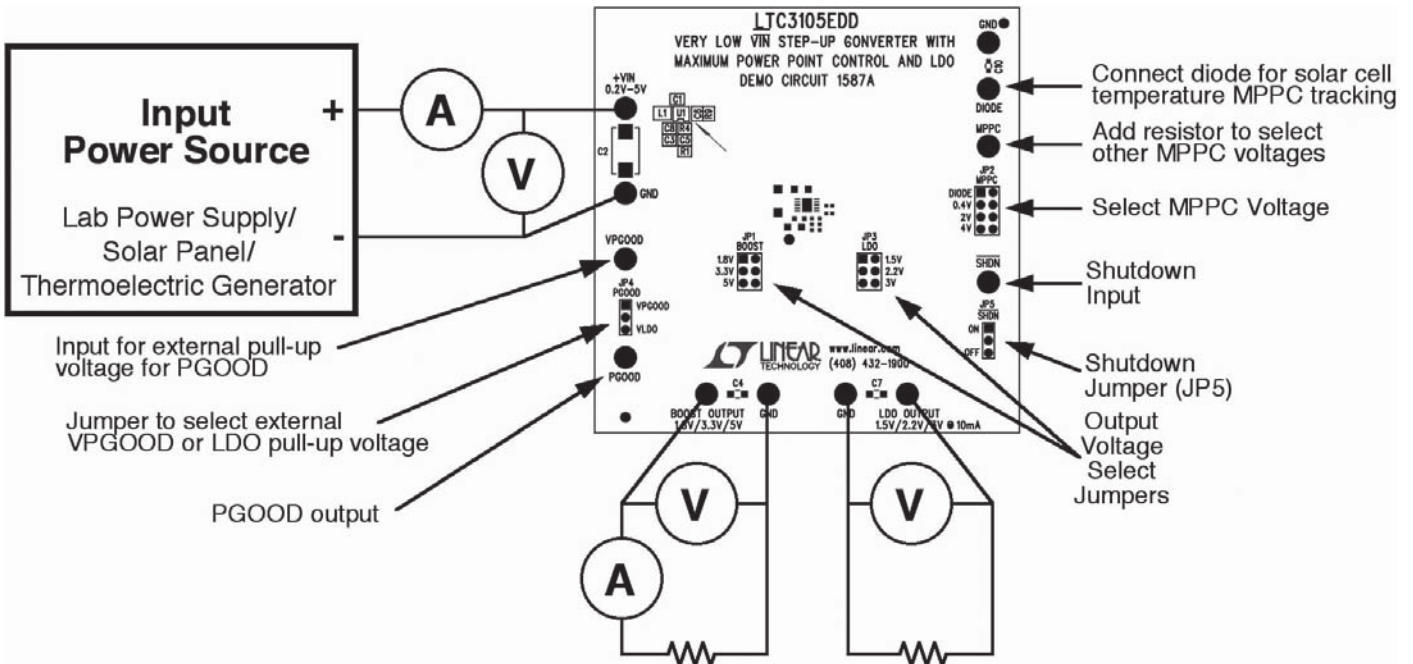

Figure 1. Proper Measurement Equipment Setup

QUICK START PROCEDURE

As the output load current increases, the voltage on V_{IN} decreases due to the 10Ω input resistor. Figure 2 shows V_{IN} , V_{OUT} and PGOOD voltages as the load current is increased over a 2 second time period with the MPPC programmed for 2V. The output remains at a regulated 5V until the input voltage drops to the 2V MPPC threshold. The MPPC prevents the input voltage from dropping below 2V by reducing the output voltage. Without MPPC, the output voltage would drop to near 0V resulting in zero output power. Connecting the MPPC pin to GND will disable the MPPC function. Also shown in Figure 1 is the Power Good (PGOOD) signal that pulls low when the Boost output voltage drops 10% below the programmed value.

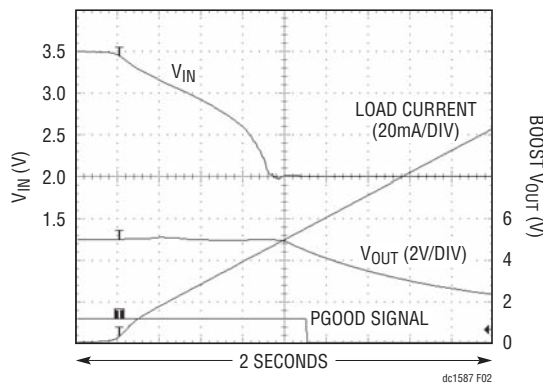

Figure 2. Maximum Power Point Control Programmed for 2V, Operating from a High Impedance Input Power Source (10Ω)

3. To verify very low voltage start-up (250mV to 300mV) it is necessary to do the following; remove jumper JP2 and add an external 22k resistor between the MPPC ter-

minal and ground. Connect a resistor of approximately 0.5Ω between the supply output and V_{IN} . Adjust the supply to approximately 250mV to 300mV and verify that the boost output is in regulation. Since this DC/DC converter is designed to operate from relatively high impedance power sources, some source resistance is necessary for proper low voltage start-up. At very low input voltage, excessive input current may result unless there is some source resistance.

4. Additional demo board features include the following. Jumper JP4 allows the PGOOD open drain FET pull-up resistor to be connected to the LDO output voltage or to an external voltage applied to the VPGOOD terminal. The converter can be shutdown by pulling \overline{SHDN} terminal low. MPPC jumper allows the user to select several preset MPPC voltages or select the DIODE terminal when using diodes located near the solar panel for MPPC temperature tracking. A small circular pad on the board allows the LTC3105 AUX pin to be probed when evaluating the circuit. Do not connect a load to this pad.

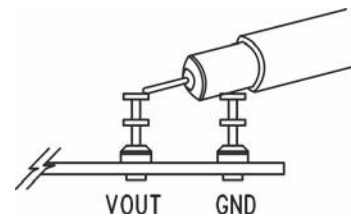

Figure 3. Correct Method For Measuring Input or Output Voltage Ripple

DEMO MANUAL DC1587

PARTS LIST

ITEM	QUANTITY	REFERENCE	PART DESCRIPTION	MANUFACTURER, PART NUMBER
Required Circuit Components				
1	1	C1	Capacitor, X5R, 10 μ F, 6.3V, 10%, 0805	AVX, 08056D106KAT2A
2	1	C3	Capacitor, X5R, 10 μ F, 16V, 10%, 0805	Taiyo Yuden, EMK212BJ106KG-T
3	1	C5	Capacitor, NPO, 33pF, 25V, 5%, 0402	AVX, 04023A330JAT2A
4	1	C8	Capacitor, X5R, 1 μ F, 16V, 10%, 0603	AVX, 0603YD105KAT2A
5	1	L1	Inductor, 10 μ H	Sumida, CDRH3D18NP-100N
6	1	R1	Resistor, Chip, 392k, 1/16W, 1%, 0402	Vishay, CRCW0402392KFKED
7	1	R4	Resistor, Chip, 499k, 1/16W, 1%, 0402	Vishay, CRCW0402499KFKED
8	1	R6	Resistor, Chip, 40.2k, 1/16W, 1%, 0402	Vishay, CRCW0402402KFKED
9	1	R10	Resistor, Chip, 100k, 1/16W, 1%, 0402	Vishay, CRCW0402100KFKED
10	1	U1	IC, LTC3105EDD, 3mm \times 3mm DFN	Linear Technology, LTC3105EDD
Additional Circuit Components				
1	0	C2	Tantalum, OPT	
2	1	C4	Capacitor, X5R, 1 μ F, 16V, 10%, 0805	AVX, 0805YD105KAT2A
3	1	C6	Capacitor, NPO, 33pF, 25V, 5%, 0402	AVX, 04023A330JAT2A
4	1	C7	Capacitor, X5R, 4.7 μ F, 16V, 10%, 0805	Taiyo Yuden, EMK212BJ475MG-T
5	1	C10	Capacitor, X7R, 10nF, 50V, 10%, 0603	AVX, 06035C103KAT2A
6	1	R2	Resistor, Chip, 750k, 1/16W, 1%, 0402	Vishay, CRCW0402750KFKED
7	1	R3	Resistor, Chip, 845k, 1/16W, 1%, 0402	Vishay, CRCW0402845KFKED
8	1	R5	Resistor, Chip, 0, 0402	Vishay, CRCW04020000JKED
9	1	R7	Resistor, Chip, 200k, 1/16W, 1%, 0402	Vishay, CRCW0402200KFKED
10	1	R8	Resistor, Chip, 402k, 1/16W, 1%, 0402	Vishay, CRCW0402402KFKED
11	1	R9	Resistor, Chip, 549k, 1/16W, 1%, 0402	Vishay, CRCW0402549KFKED
12	1	R11	Resistor, Chip, 274k, 1/16W, 1%, 0402	Vishay, CRCW0402274KFKED
13	1	R12	Resistor, Chip, 1.1M, 1/16W, 1%, 0402	Vishay, CRCW04021M10FKED
Hardware				
1	12	E1-E12	Testpoint, Turret, 0.095"	Mill-Max, 2501-2-00-80-00-00-07-0
2	2	JP4, JP5	0.079 Single Row Header, 3-Pin	Samtec, TMM-103-02-L-S
3	1	JP2	2mm Double Row Header 4mm \times 2mm	Samtec, TMM-104-02-L-D
4	2	JP1, JP3	2mm Double Row Header 2mm \times 3mm	Samtec, TMM-103-02-L-D
5	5	JP1-JP5	Shunt	Samtec, 2SN-BK-G

SCHEMATIC DIAGRAM

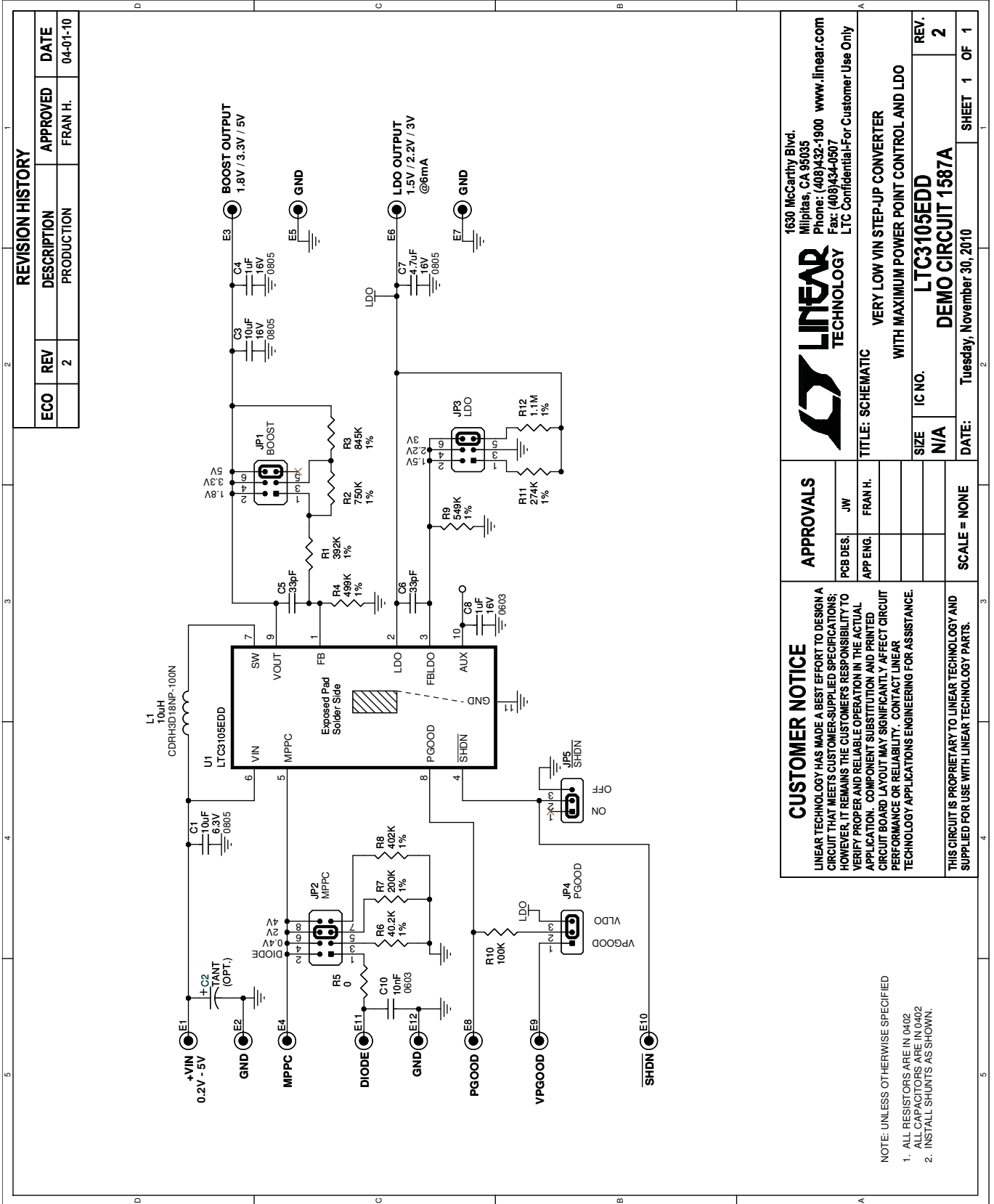

REVISION HISTORY				
ECO	REV	DESCRIPTION	APPROVED	DATE
	2	PRODUCTION	FRAN H.	04-01-10

		1630 McCarthy Blvd. Milpitas, CA 95035 Phone: (408)432-1900 www.linear.com Fax: (408)434-0507 LTC Confidential-For Customer Use Only	
TITLE: SCHEMATIC VERY LOW VIN STEP-UP CONVERTER WITH MAXIMUM POWER POINT CONTROL AND LDO			
SIZE	IC NO.	REV.	
N/A	LTC3105EDD	2	
DATE: Tuesday, November 30, 2010		SHEET 1 OF 1	

CUSTOMER NOTICE LINEAR TECHNOLOGY HAS MADE A BEST EFFORT TO DESIGN A CIRCUIT THAT MEETS CUSTOMER-SUPPLIED SPECIFICATIONS; HOWEVER, IT REMAINS THE CUSTOMER'S RESPONSIBILITY TO VERIFY PROPER AND RELIABLE OPERATION IN THE ACTUAL APPLICATION. COMPONENT SUBSTITUTION AND PRINTED CIRCUIT BOARD LAYOUT MAY SIGNIFICANTLY AFFECT CIRCUIT PERFORMANCE OR RELIABILITY. CONTACT LINEAR TECHNOLOGY APPLICATIONS ENGINEERING FOR ASSISTANCE.		APPROVALS PCB DES. JW APP ENG. FRAN H.	
THIS CIRCUIT IS PROPRIETARY TO LINEAR TECHNOLOGY AND SUPPLIED FOR USE WITH LINEAR TECHNOLOGY PARTS.		SCALE = NONE	

NOTE: UNLESS OTHERWISE SPECIFIED
 1. ALL RESISTORS ARE IN 0402
 ALL CAPACITORS ARE IN 0402
 2. INSTALL SHUNTS AS SHOWN.

DEMO MANUAL DC1587

DEMONSTRATION BOARD IMPORTANT NOTICE

Linear Technology Corporation (LTC) provides the enclosed product(s) under the following **AS IS** conditions:

This demonstration board (DEMO BOARD) kit being sold or provided by Linear Technology is intended for use for **ENGINEERING DEVELOPMENT OR EVALUATION PURPOSES ONLY** and is not provided by LTC for commercial use. As such, the DEMO BOARD herein may not be complete in terms of required design-, marketing-, and/or manufacturing-related protective considerations, including but not limited to product safety measures typically found in finished commercial goods. As a prototype, this product does not fall within the scope of the European Union directive on electromagnetic compatibility and therefore may or may not meet the technical requirements of the directive, or other regulations.

If this evaluation kit does not meet the specifications recited in the DEMO BOARD manual the kit may be returned within 30 days from the date of delivery for a full refund. **THE FOREGOING WARRANTY IS THE EXCLUSIVE WARRANTY MADE BY THE SELLER TO BUYER AND IS IN LIEU OF ALL OTHER WARRANTIES, EXPRESSED, IMPLIED, OR STATUTORY, INCLUDING ANY WARRANTY OF MERCHANTABILITY OR FITNESS FOR ANY PARTICULAR PURPOSE. EXCEPT TO THE EXTENT OF THIS INDEMNITY, NEITHER PARTY SHALL BE LIABLE TO THE OTHER FOR ANY INDIRECT, SPECIAL, INCIDENTAL, OR CONSEQUENTIAL DAMAGES.**

The user assumes all responsibility and liability for proper and safe handling of the goods. Further, the user releases LTC from all claims arising from the handling or use of the goods. Due to the open construction of the product, it is the user's responsibility to take any and all appropriate precautions with regard to electrostatic discharge. Also be aware that the products herein may not be regulatory compliant or agency certified (FCC, UL, CE, etc.).

No License is granted under any patent right or other intellectual property whatsoever. **LTC assumes no liability for applications assistance, customer product design, software performance, or infringement of patents or any other intellectual property rights of any kind.**

LTC currently services a variety of customers for products around the world, and therefore this transaction **is not exclusive**.

Please read the DEMO BOARD manual prior to handling the product. Persons handling this product must have electronics training and observe good laboratory practice standards. **Common sense is encouraged.**

This notice contains important safety information about temperatures and voltages. For further safety concerns, please contact a LTC application engineer.

Mailing Address:

Linear Technology
1630 McCarthy Blvd.
Milpitas, CA 95035

Copyright © 2004, Linear Technology Corporation