

LOC		DIST		REVISIONS			
P	LTR	DESCRIPTION	DATE	DWN	APVD		
P		REV PER ECO-15-016062	10NOV15	KG	CD		

- THIS RCPT. IS DESIGNED TO CONFORM TO THE LATEST ISSUE OF MIL-C-24308.
 - MAX WIRE INSUL TO BE USED WITH THIS RCPT IS .068 DIA.
 - STAINLESS STEEL RETENTION CLIPS ARE INCLUDED IN INSERTS.
 - THIS RCPT. WILL ACCEPT SIZE 20 SOCKET CONTACT M39029/63-368 OR ANY TYCO HD-20 SOCKET CONTACT. CONTACTS ORDERED SEPARATELY.
- 5 TYCO PART NO. MARKED ON CONNECTOR REPRESENTS KIT NUMBER WITH CONTACTS.
6 UL/CSA DESIGNATION STAMPED IN THIS AREA, OPTIONAL.
7 CADMIUM PER QQ-P-416.
8 BRIGHT TIN PER ASTM-B-545 .000400-.000550 THK OVER COPPER PER AMS2418 .000050 MIN THK.

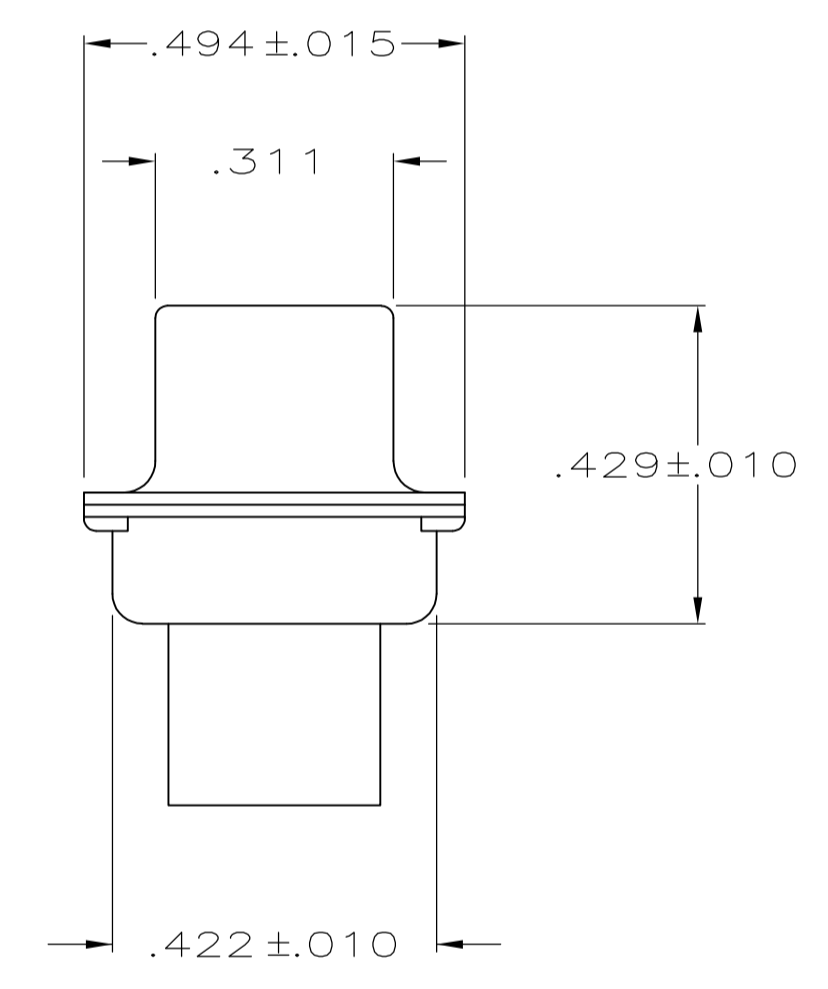
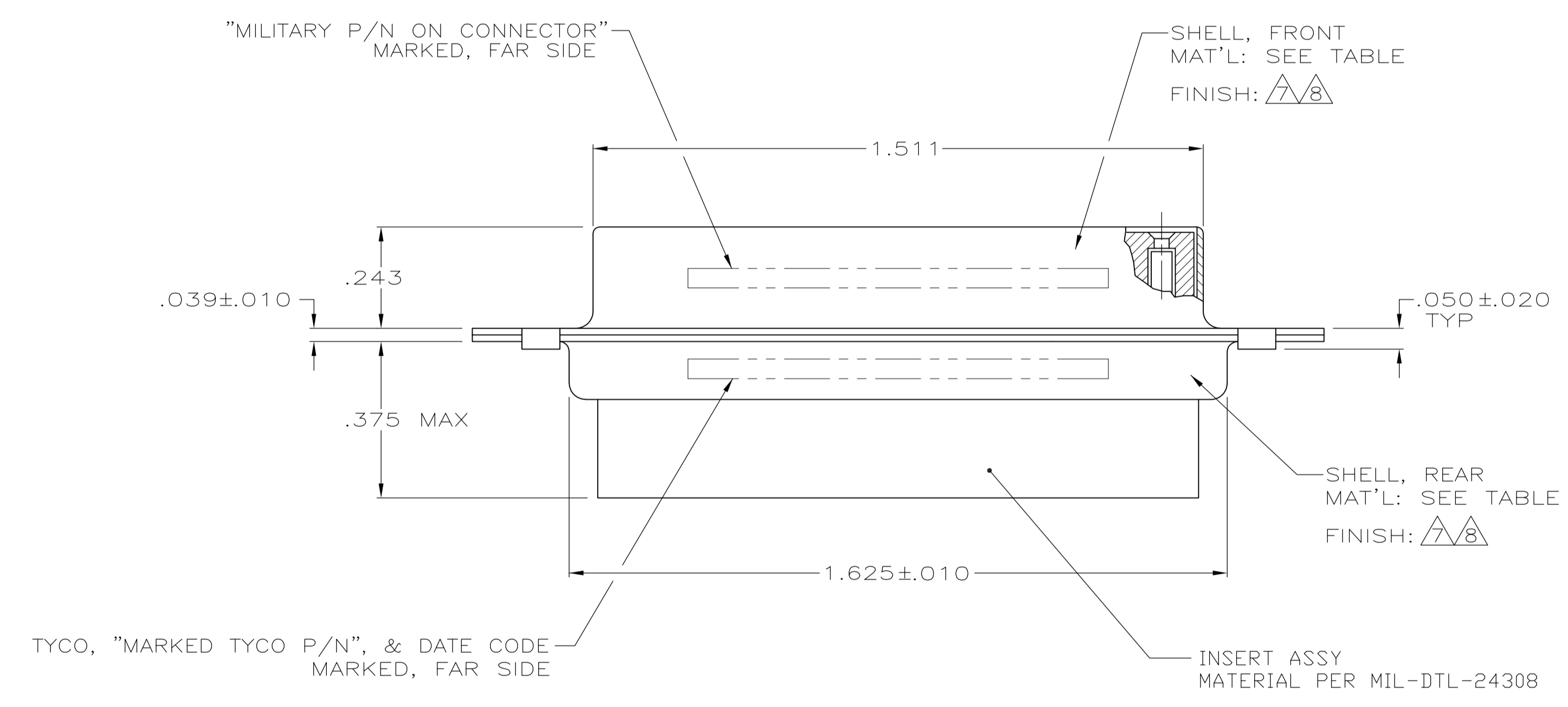
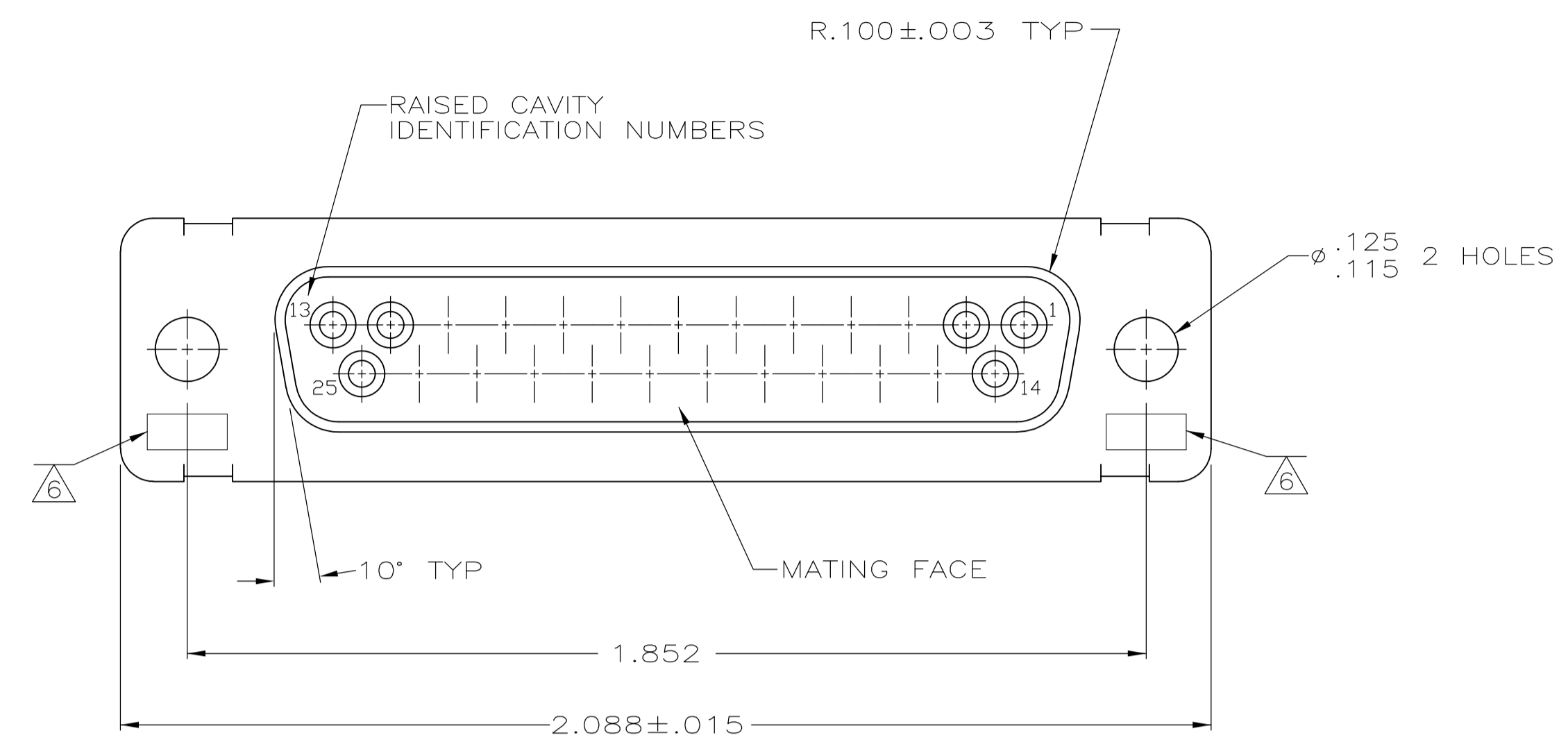

205165-4	-	-	-	8	STEEL PER ASTM-A-109	205165-4
SUPSD BY 206801-2	-	-	-	-	BRASS	205165-2
205559-2	M24308/2-283F	M24308/2-3F	5	7	STEEL PER ASTM-A-109	205165-1
TYCO P/N MARKED ON CONNECTOR	MILITARY P/N ON PACKAGE	MILITARY P/N ON CONNECTOR	REMARKS	SHELL FINISH	SHELL MAT'L	PART NO.

THIS DRAWING IS A CONTROLLED DOCUMENT.

DIMENSIONS: INCHES	TOLERANCES UNLESS OTHERWISE SPECIFIED:	DIN C.C.THOMAS 12-DEC-87	TE Connectivity
0 PLC ± - 1 PLC ± - 2 PLC ± - 3 PLC ± .005 4 PLC ± - ANGLES ± 0'30"	FINISH SEE CALLOUTS	CHK F.C.BALLEW 10-DEC-87 APVD F.C.BALLEW 10-DEC-87 PRODUCT SPEC APPLICATION SPEC SIZE A1 CAGE CODE 00779 DRAWING NO. 205165	
MATERIAL SEE CALLOUTS	FINISH SEE CALLOUTS	WEIGHT -	RESTRICTED TO

CUSTOMER DRAWING SCALE 4:1 SHEET 1 OF 1 REV P