

ORDER NO.	WOODHEAD NO.	COLOR
130144-0071	5769	BLACK

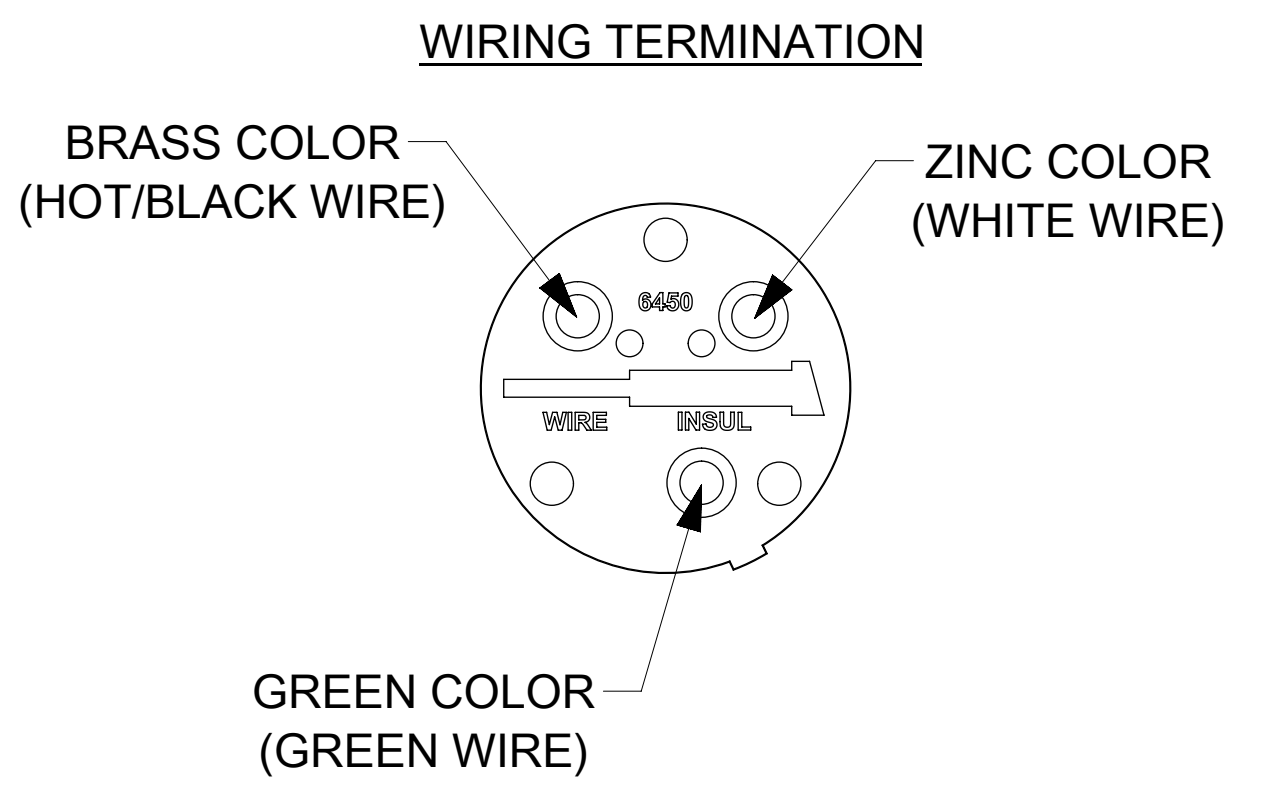
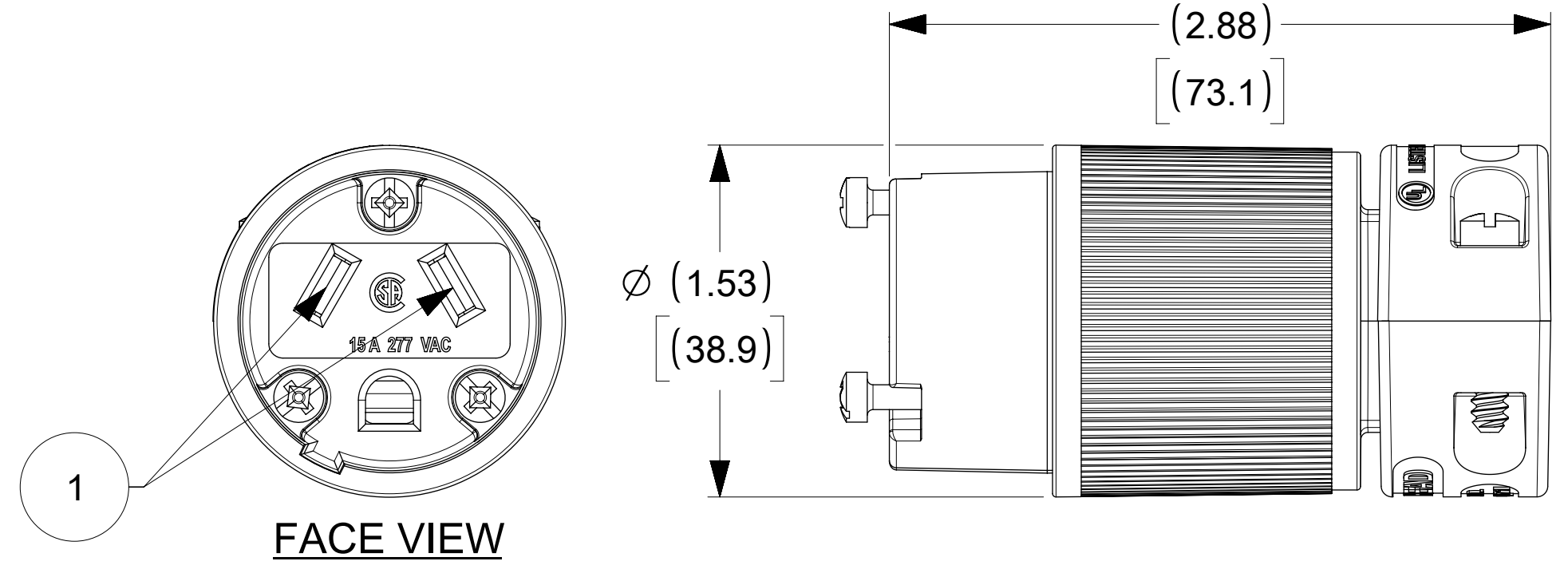
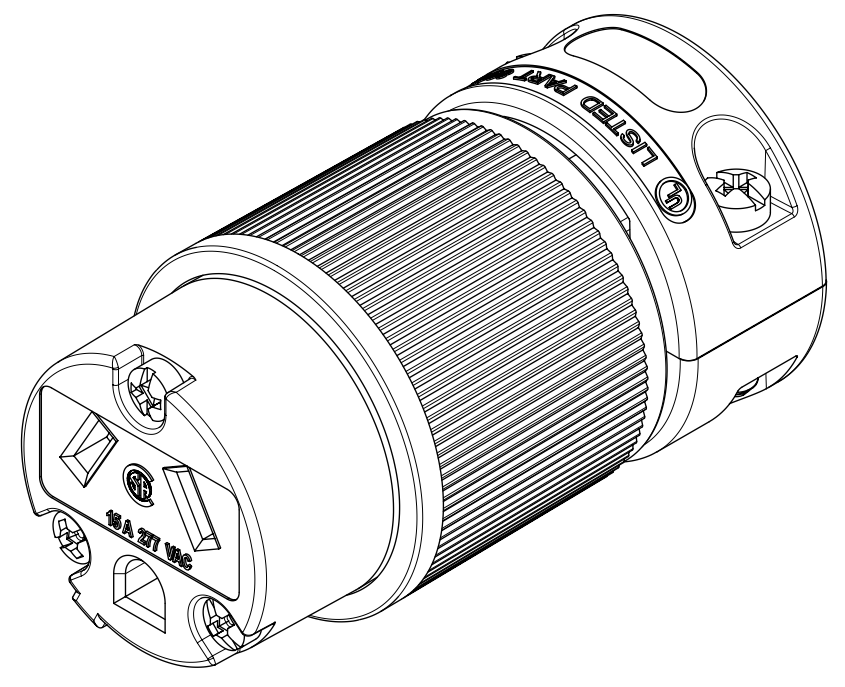
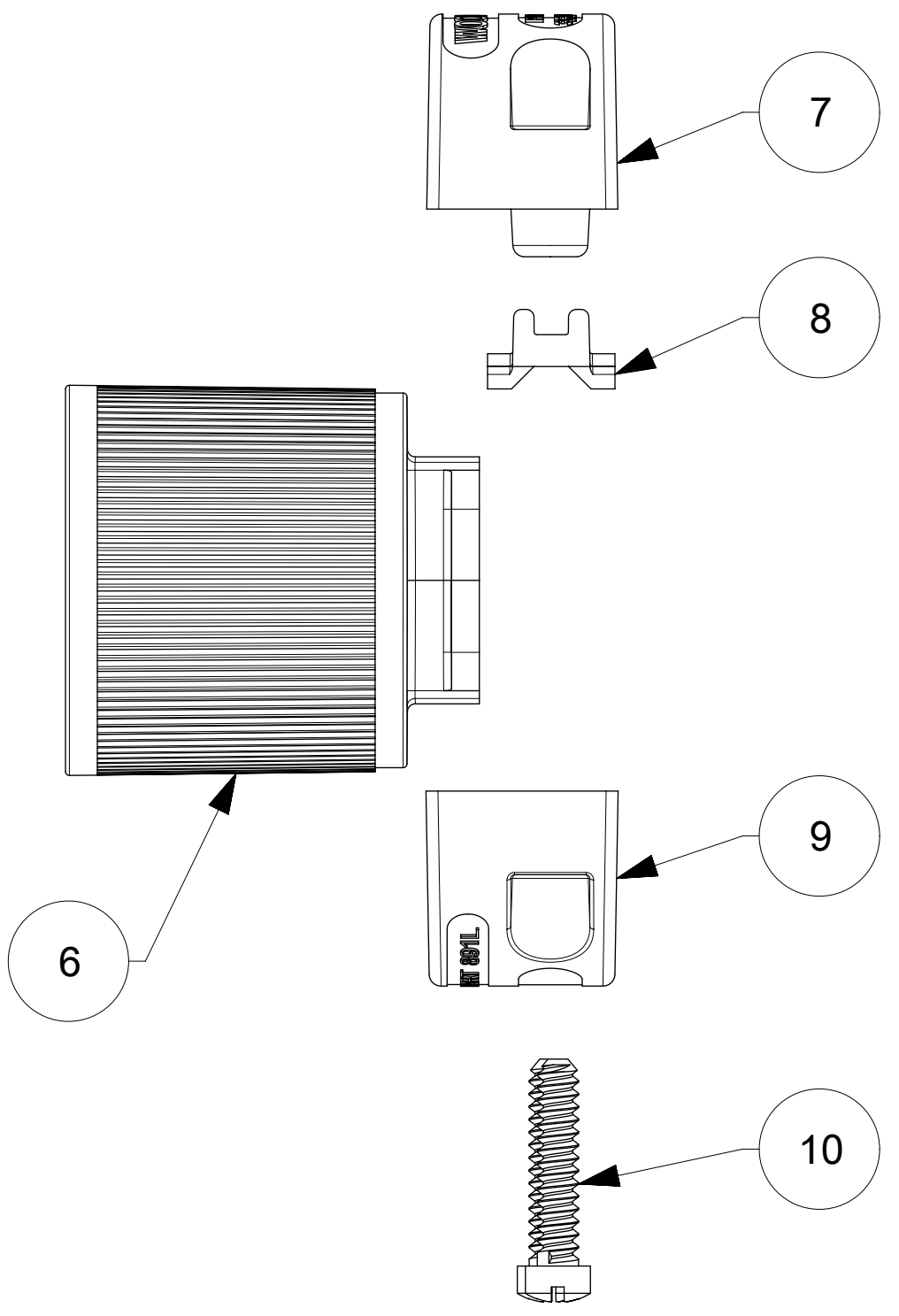
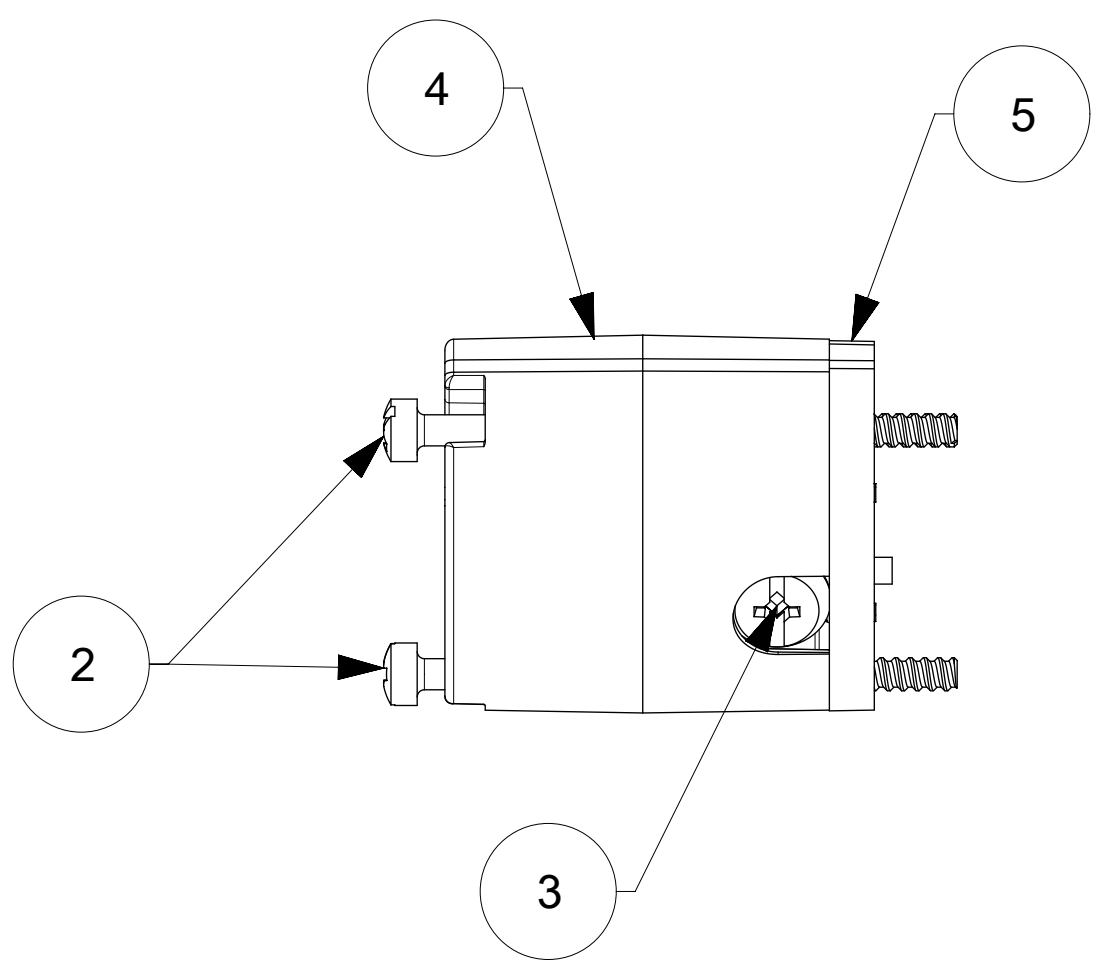

ITEM NO.	DESCRIPTIONS	MATERIAL	QTY.
1	BLADES	BRASS	3
2	RETAINING SCREWS	STAINLESS STEEL	3
3	TERMINAL SCREWS/CLAMP ASSEMBLY	BRASS, ZINC PLATED	3
4	INSERT	NYLON	1
5	TERMINAL COVER	POLYCARBONATE	1
6	HOUSING; BLACK	NYLON	1
7	CLAMP CORD MALE	NYLON	1
8	CLAMP CORD INSERT	NYLON	1
9	CLAMP CORD FEMALE	NYLON	1
10	RETAINING SCREWS	STEEL, ZINC PLATED	2

THIS DRAWING CONTAINS INFORMATION THAT IS PROPRIETARY TO MOLEX ELECTRONIC TECHNOLOGIES, LLC AND SHOULD NOT BE USED WITHOUT WRITTEN PERMISSION			
DIMENSION UNITS: INCH[MM]		SCALE: NTS	
CURRENT REV DESC: NEW RELEASE			
GENERAL TOLERANCES (UNLESS SPECIFIED)		EC NO: 621092	
4 PLACES	±	±	DRWN: VBASUTHKARP 2019/02/08
3 PLACES	±	±	CHK'D: DNGUYEN62 2019/10/30
2 PLACES	±	±	APPR: HKNEELAND 2020/02/05
1 PLACE	±	±	INITIAL REVISION:
0 PLACES	±	±	DRWN: VBASUTHKARP 2019/02/08
ANGULAR TOL ± °		APPR: HKNEELAND 2020/02/05	
DRAFT WHERE APPLICABLE MUST REMAIN WITHIN DIMENSIONS		THIRD ANGLE PROJECTION	DRAWING SERIES: C-SIZE 130144
DOCUMENT NUMBER: 1301440071		DOC TYPE: PSD	DOC PART: 000
MATERIAL NUMBER: SEE TABLE		CUSTOMER: GENERAL MARKET	
SHEET NUMBER: 1 OF 1		REVISION: A	