

DESCRIPTION

The popular 1N3154 thru 1N3157A series of Zero-TC Reference Diodes provides a selection of 8.4 V nominal voltages and temperature coefficients to as low as 0.001 %/ $^{\circ}\text{C}$ for minimal voltage change with temperature when operated at 10.0 mA. These glass axial-leaded DO-7 reference diodes are also available in JAN, JANTX, and JANTXV military qualifications. As a further option for commercial product, they are available as RoHS Compliant with an e3 suffix added to the part number. Microsemi also offers numerous other Zener Reference Diode products for a variety of other voltages from 6.2 V to 200 V.

APPEARANCE

**DO-7
(DO-204AA)**

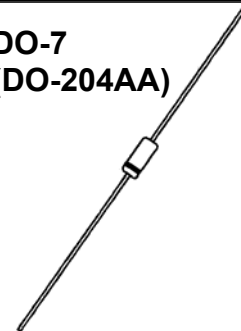

IMPORTANT: For the most current data, consult MICROSEMI's website: <http://www.microsemi.com>

FEATURES

- JEDEC registered 1N3154 thru 1N3157A series
- Standard reference voltage of 8.4V +/- 5% with tighter tolerances available
- 1N3154, 3155, 3156, and 3157 also have military qualification to MIL-PRF-19500/158 up to the JANTXV level by adding JAN, JANTX, or JANTXV prefixes to part numbers as well as "-1" suffix, e.g. JANTX1N3157-1, etc.
- Internal metallurgical bonds
- JANS Equivalent available via SCD
- Radiation Hardened devices available by changing 1N prefix to RH, e.g. RH3156, RH3157, RH3157A, etc. Also consult factory for "RH" data sheet brochure
- RoHS Compliant devices available by adding an "e3" suffix (not applicable to military)

APPLICATIONS / BENEFITS

- Provides minimal voltage changes over a broad temperature range
- For instrumentation and other circuit designs requiring a stable voltage reference
- Maximum temperature coefficient selections available from 0.01%/ $^{\circ}\text{C}$ to 0.001%/ $^{\circ}\text{C}$
- Tight reference voltage tolerances at the 8.4 V nominal is available by adding tolerance 1%, 2%, 3%, etc. after the part number for identification e.g. 1N3156-2%, 1N3157A-1%, 1N3157-1-1%, etc.
- Flexible axial-lead mounting terminals
- Nonsensitive to ESD per MIL-STD-750 Method 1020

MAXIMUM RATINGS

- Operating & Storage Temperature: -65 $^{\circ}\text{C}$ to +175 $^{\circ}\text{C}$
- DC Power Dissipation: 500 mW @ T_L = 25 $^{\circ}\text{C}$ and maximum current I_{ZM} of 55 mA. NOTE: For optimum voltage-temperature stability, I_Z = 10.0 mA (less than 90 mW in dissipated power)
- Solder temperatures: 260 $^{\circ}\text{C}$ for 10 s (maximum)

MECHANICAL AND PACKAGING

- CASE: Hermetically sealed glass case with DO-7 (DO-204AA) package
- TERMINALS: Tin-Lead (military) or RoHS Compliant annealed matte-Tin plating solderable per MIL-STD-750, Method 2026
- MARKING: Part number and cathode band
- POLARITY: Reference diode to be operated with the banded end positive with respect to the opposite end
- TAPE & REEL option: Standard per EIA-296 (add "TR" suffix to part number)
- WEIGHT: 0.2 grams.
- See package dimensions on last page

* ELECTRICAL CHARACTERISTICS @25°C, unless otherwise specified

JEDEC TYPE NUMBERS (Notes 1, 5 & 6)	ZENER VOLTAGE $V_z @ I_{zT}$ (Note 1)	ZENER TEST CURRENT I_{zT}	MAXIMUM ZENER IMPEDANCE (Note 2) Z_{zT}	MAXIMUM REVERSE CURRENT $I_R @ 5.5 V$	VOLTAGE TEMPERATURE STABILITY (Note 3 & 4) ΔV_{zT} MAXIMUM	TEMPERATURE RANGE	EFFECTIVE TEMPERATURE COEFFICIENT α_{vz}
	VOLTS	mA	OHMS	μA	mV	°C	%/°C
1N3154	8.00-8.80	10	15	10	130	-55 to +100	0.01
1N3154A	8.00-8.80	10	15	10	172	-55 to +150	0.01
1N3155	8.00-8.80	10	15	10	65	-55 to +100	0.005
1N3155A	8.00-8.80	10	15	10	86	-55 to +150	0.005
1N3156	8.00-8.80	10	15	10	26	-55 to +100	0.002
1N3156A	8.00-8.80	10	15	10	34	-55 to +150	0.002
1N3157	8.00-8.80	10	15	10	13	-55 to +100	0.001
1N3157A	8.00-8.80	10	15	10	17	-55 to +150	0.001

*JEDEC Registered Data.

NOTES:

1. When ordering devices with tighter tolerance than specified, add a hyphenated suffix to the part number for desired tolerance, e.g. 1N3156-2%, 1N3157A-1%, 1N3157-1-1%, etc.
2. Measured by superimposing 1.0 mA ac rms on 10 mA dc @ 25°C.
3. The maximum allowable change observed over the entire temperature range i.e., the diode voltage will not exceed the specified mV change at any discrete temperature between the established limits.
4. Voltage measurements to be performed 15 seconds after application of dc current.
5. The 1N3154, 1N3155, 1N3156, and 1N3157 also have military qualification to MIL-PRF-19500/158 up to the JANTXV level by adding JAN, JANTX, or JANTXV prefix to part numbers as well as "-1" suffix, e.g. JANTX1N3156-1, JANTXV1N3157-1, etc.
6. Designate Radiation Hardened devices with "RH" prefix instead of "IN", i.e. RH3157A instead of 1N3157A.

GRAPHS

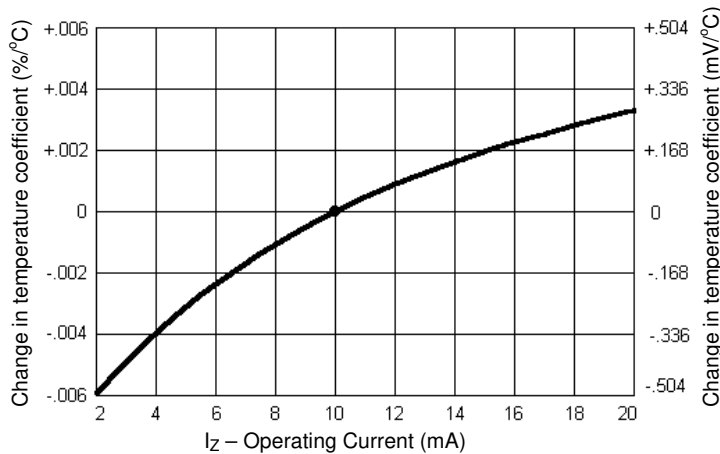

FIGURE 1

TYPICAL CHANGE OF TEMPERATURE COEFFICIENT WITH CHANGE IN OPERATING CURRENT.

The curve shown in Figure 1 is typical of the diode series and greatly simplifies the estimation of the Temperature Coefficient (TC) when the diode is operated at currents other than 10mA.

EXAMPLE: A diode in this series is operated at a current of 10mA and has specified Temperature Coefficient (TC) limits of +/-0.005%/°C. To obtain the typical Temperature Coefficient limits for this same diode operated at a current of 7.5mA, the new TC limits (%/°C) can be estimated using the graph in FIGURE 1.

At a test current of 7.5mA the change in Temperature Coefficient (TC) is approximately -0.0012%/°C. The algebraic sum of +/-0.005%/°C and -0.0012%/°C gives the new estimated limits of +0.0038%/°C and -0.0062%/°C.

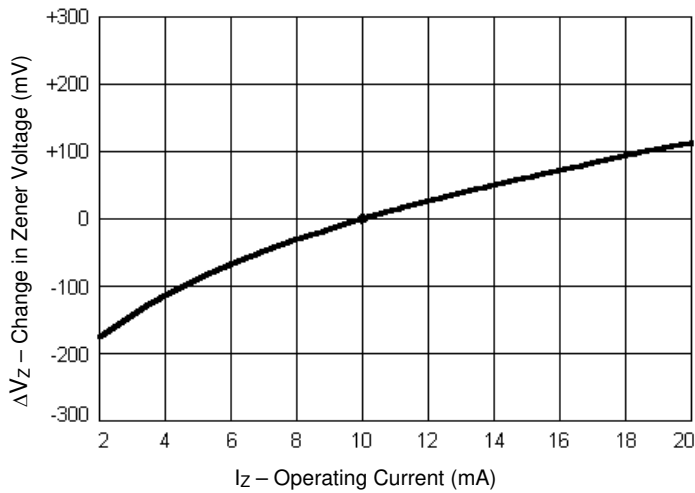

This curve in Figure 2 illustrates the change of diode voltage arising from the effect of impedance. It is in effect, an exploded view of the zener operating region of the I-V characteristic.

In conjunction with Figure 1, this curve can be used to estimate total voltage regulation under conditions of both varying temperature and current.

FIGURE 2
TYPICAL CHANGE OF ZENER VOLTAGE WITH CHANGE IN OPERATING CURRENT.

DIMENSIONS

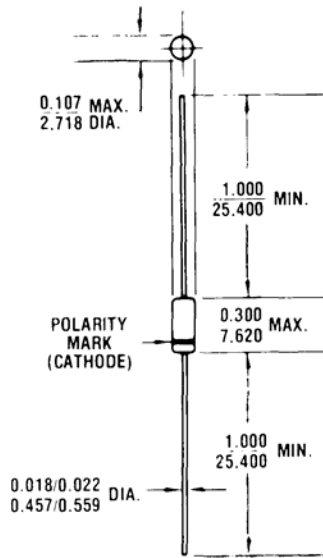

All dimensions in INCH
mm