

Wet Tantalum Capacitors, High Energy, Ultra High Capacitance, -55 °C to +125 °C Operation



FEATURES

- High energy, very high capacitance design
- All tantalum, hermetically sealed case
- Utilizes Vishay proven SuperTan® technology
- EP1: 2 terminations options: SMD and radial
- PATENT(S): www.vishay.com/patents
- Material categorization: for definitions of compliance please see www.vishay.com/doc?99912



Note

* This datasheet provides information about parts that are RoHS-compliant and / or parts that are non RoHS-compliant. For example, parts with lead (Pb) terminations are not RoHS-compliant. Please see the information / tables in this datasheet for details

APPLICATIONS

- Industrial
- Avionics / military / space
- Ideal for capacitor banks

LINKS TO ADDITIONAL RESOURCES



PERFORMANCE CHARACTERISTICS

Operating Temperature:

-55 °C to +85 °C (to +125 °C with voltage derating)

Capacitance Tolerance:

at 120 Hz, +25 °C ± 20 % standard
± 10 % available as special

Contact marketing for availability of 10 % tolerance

DC Leakage Current (DCL Max.):

at +25 °C: leakage current shall not exceed the values listed in the Standard Ratings tables.

Life Test:

capacitors are capable of withstanding a 2000 h life test at a temperature of +85 °C at the applicable rated DC working voltage.

EP2 ORDERING INFORMATION								
EP2 TYPE	C CASE CODE	723 CAPACITANCE	K CAPACITANCE TOLERANCE	25 DC VOLTAGE RATING AT +85 °C	B TERMINATION CODE	Z ANODE TERMINAL LENGTH	S ESR	MOUNTING STUD LENGTH
	See Dimensions sheets	This is expressed in microfarads. The first two digits are the significant figures. The third is the number of zeros to follow.	K = 10 % (1) M = 20 %	This is expressed in V. To complete the three-digit block, zeros precede the voltage rating. A decimal point is indicated by an "R"	See termination / mounting options in the Dimensions sheets.	Z = std = 0.230" See Dimensions sheets	S = standard	Blank = not applicable See Dimensions sheets

Note

(1) Contact marketing for availability of 10 % tolerance

PATENT(S): www.vishay.com/patents

This Vishay product is protected by one or more United States and international patents.



EP1 ORDERING INFORMATION									
EP1 TYPE	A CASE CODE	303 CAPACITANCE	K CAPACITANCE TOLERANCE	25 DC VOLTAGE RATING AT +85 °C	B TERMINATION CODE	Z RELIABILITY LEVEL	S TEMPERATURE	S ESR	MOUNTING STUD LENGTH
	See Dimensions sheets	This is expressed in microfarads. The first two digits are the significant figures. The third is the number of zeros to follow.	K = 10 % ⁽¹⁾ M = 20 %	This is expressed in V. To complete the three-digit block, zeros precede the voltage rating. A decimal point is indicated by an "R" (6R3 = 6.3 V)	See termination / mounting options in the Dimensions sheets.	Z = non-ER	S = standard (-55 °C to +85 °C)	S = standard	Blank = not applicable See Dimensions sheets

Note

(1) Contact marketing for availability of 10 % tolerance

EP2 AND EP1 RATINGS AND CASE CODES (ESR mΩ)									
μF	25 V	35 V	50 V	60 V	63 V	80 V	100 V	110 V	125 V
1900									EP1A (100)
2000									EP1A (100)
2200									EP1A (110)
2700									EP2B (45)
3000							EP1A (65)		EP2B (45)
3300							EP1A (70)		
3600									EP1B / EP2B (50), EP2C (25)
3800									EP2B (50)
4000						EP1A (55)		EP2B (40)	
4200							EP2B (30)		
4400						EP1A (60)	EP1B (35), EP2B (30)		
4500									EP2C (25)
5300									EP1C / EP2C (35)
5600							EP2C (20)		EP2C (35)
5800							EP1B / EP2B (35)		
6000					EP1A (50)	EP2B (27)		EP2C (27)	
6600					EP1A (60)		EP2C (20)		
7000						EP1B (30)			
7900							EP2C (25)		
8000						EP1B / EP2B (30)			
9000						EP2B (30), EP2C (18)	EP2C (25)		
9400					EP2B (25)				
11 000					EP2B (25)				

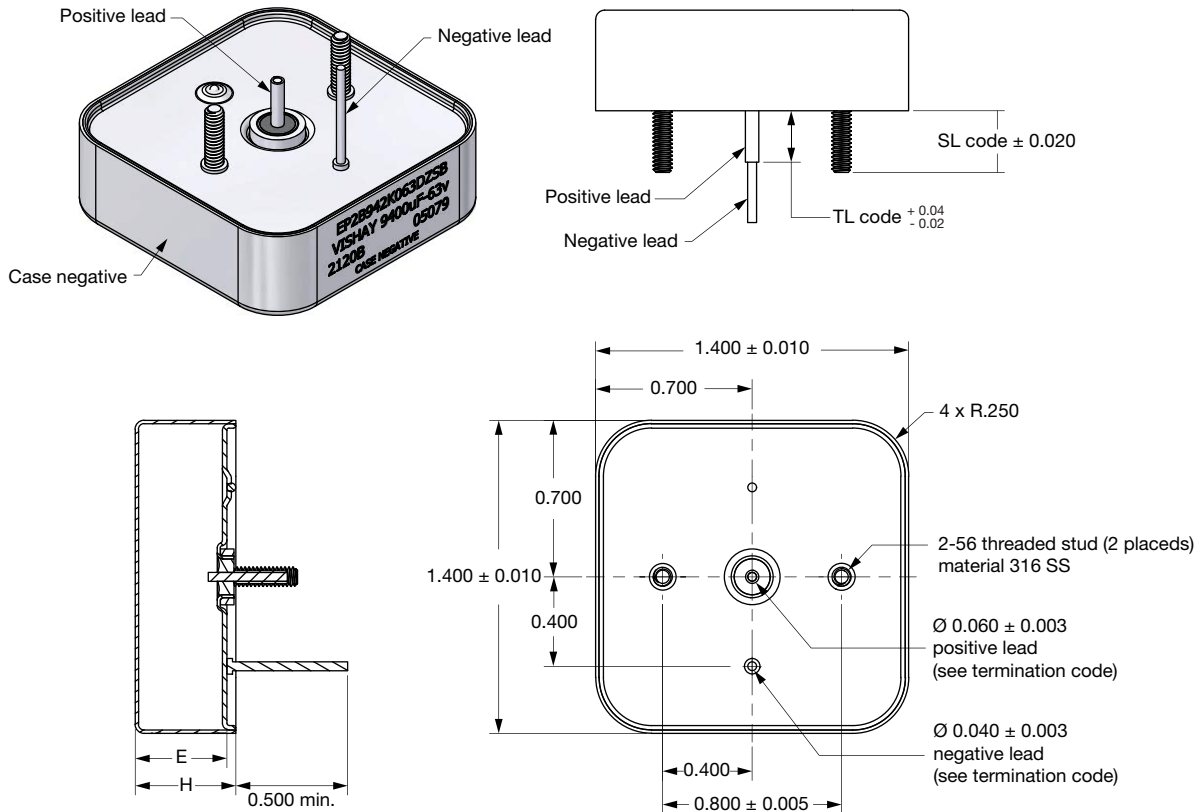

EP2 AND EP1 RATINGS AND CASE CODES (ESR mΩ)									
μF	25 V	35 V	50 V	60 V	63 V	80 V	100 V	110 V	125 V
12 000			EP1A (50)		EP1B / EP2B (25)	EP1C (25), EP2C (20)			
12 600				EP2B (25)					
13 000			EP1A (50)		EP2B (25)				
14 000					EP2C (17)	EP2C (20)			
15 000			EP1A (60)						
17 000			EP2B (25)						
18 000					EP1C / EP2C (20)				
19 000				EP2C (17)					
22 000		EP1A (40)	EP2B (25)						
23 000			EP2C (17)						
24 000			EP2B (27)						
30 000	EP1A (30)								
32 000		EP2B (20)							
33 000			EP2C (17)						
34 000			EP1C / EP2C (18)						
36 000		EP2B (22)							
37 000			EP2C (20)						
40 000		EP2B (22)							
44 000			EP2D (15)						
47 000		EP2C (15)							
48 000	EP2B (20)	EP2C (15)							
58 000		EP2C (17)							
72 000	EP2C (15)								

EP2 DIMENSIONS - RADIAL TERMINATION WITH AND WITHOUT STUDS

CASE SIZE	H	E (ref.)
B	0.450" ± 0.015"	0.410
C	0.600" ± 0.015"	0.560
D	0.755" ± 0.015"	0.715

TERMINATION CODE	TERMINATION / MOUNTING OPTION	STUDS
A	100 % tin (RoHS-compliant) radial	None
B	Tin / lead radial	None
C	100 % tin (RoHS-compliant) radial	Yes
D	Tin / lead radial	Yes

ANODE TERMINAL LENGTH CODE [TL]	LENGTH
N	0.100"
P	0.125"
R	0.156"
T	0.188"
U	0.219"
Z - STANDARD	0.230"
V	0.250"
W	0.281"
Y	0.313"

MOUNTING STUDS LENGTH CODE [SL]	LENGTH
None	Blank
A	0.21"
B	0.27"
C	0.40"
D	0.15"
E	0.18"
F	0.35"

Notes

- Upon request, spacers may be provided to fill the gap between printed circuit board and termination plane of the capacitor
- Please add "TKD" as a suffix to the part number ordered, which will include the spacer with each capacitor

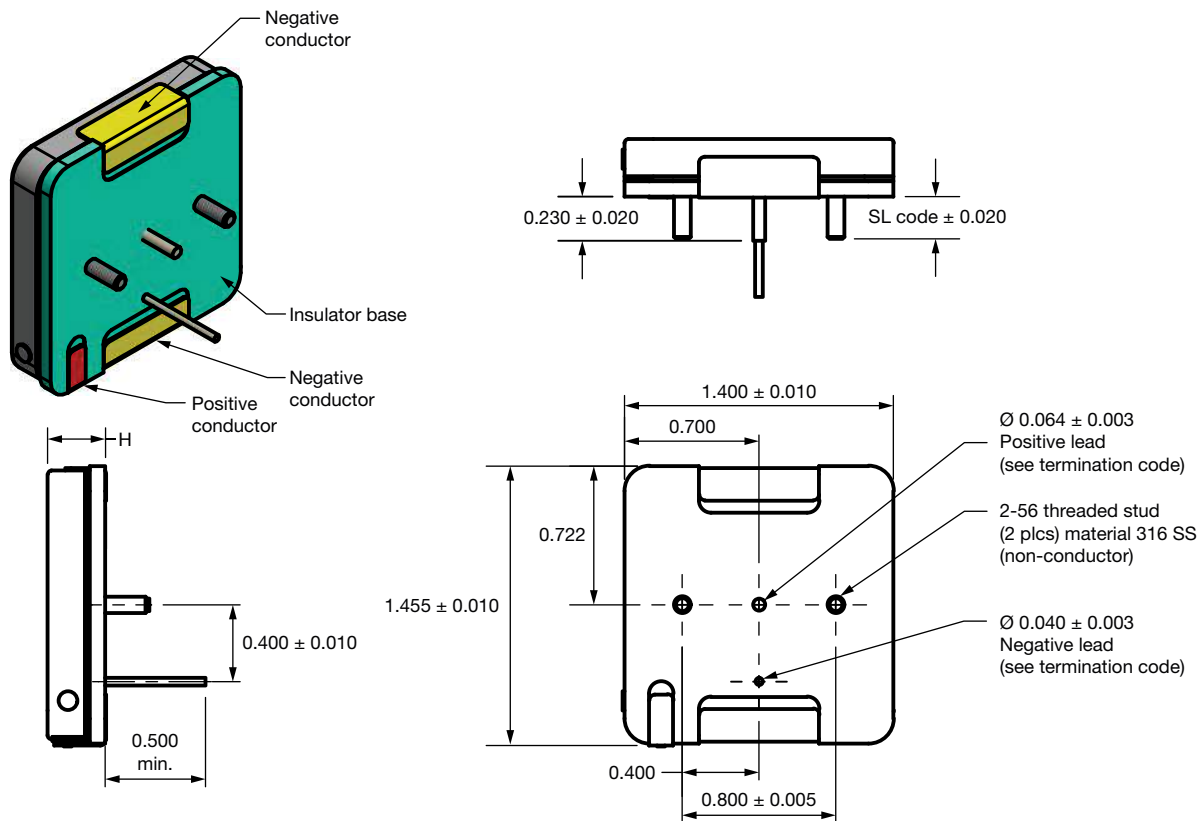
EP1 DIMENSIONS - RADIAL TERMINATION WITH AND WITHOUT STUDS

CASE SIZE	H
A	$0.312" \pm 0.015"$
B	$0.450" \pm 0.015"$
C	$0.600" \pm 0.015"$

TERMINATION CODE	TERMINATION / MOUNTING OPTION	STUDS
A	100 % tin (RoHS-compliant) radial	None
B	Tin / lead radial	None
C	100 % tin (RoHS-compliant) radial	Yes
D	Tin / lead radial	Yes

MOUNTING STUDS LENGTH CODE	LENGTH
None	Blank
A	0.21"
B	0.27"
C	0.40"
D	0.15"
E	0.18"
F	0.35"

EP1 DIMENSIONS - SMD TERMINATION WITH AND WITHOUT STUDS

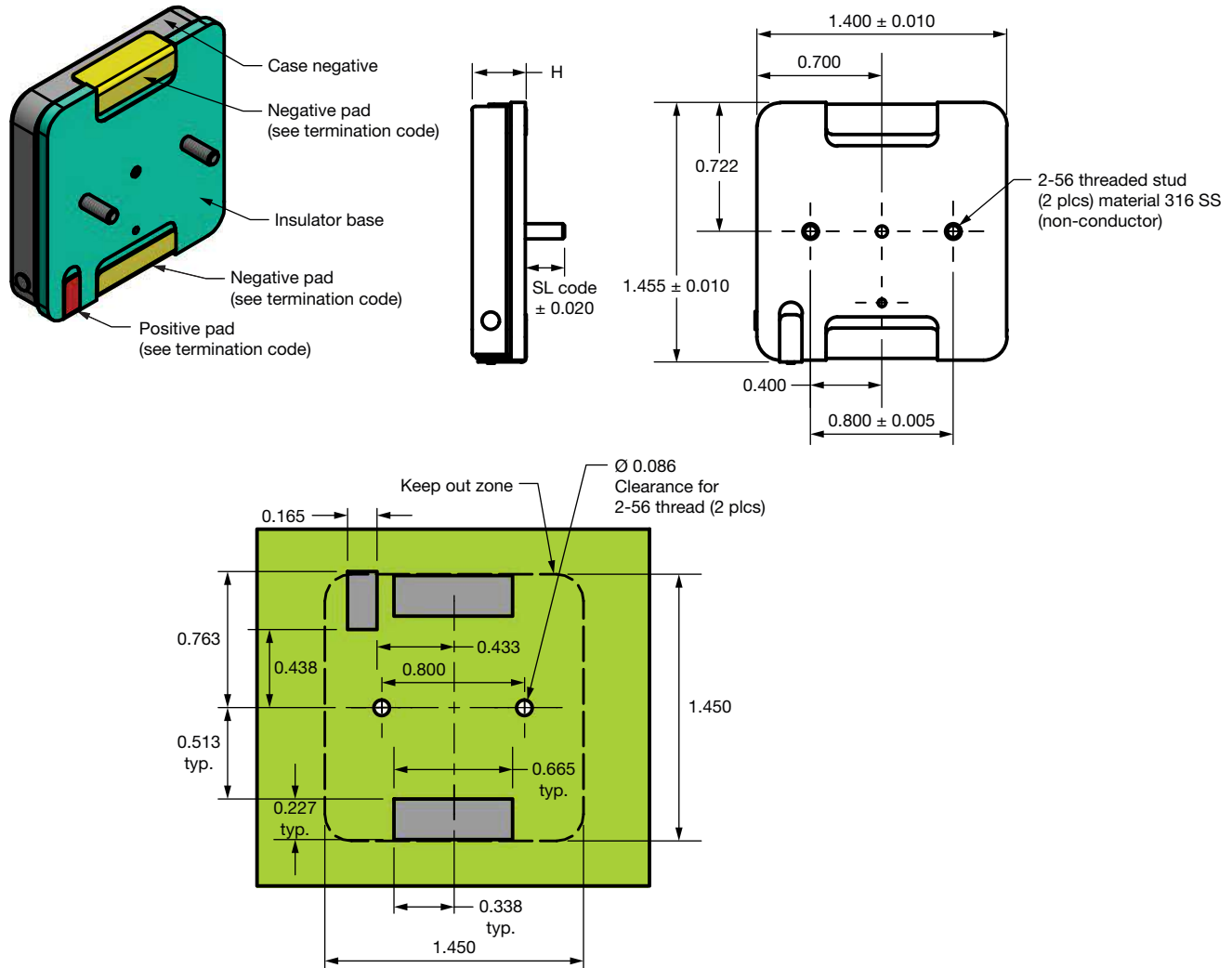

CASE SIZE	H
A	0.312" ± 0.015"
B	0.450" ± 0.015"
C	0.600" ± 0.015"

TERMINATION CODE	TERMINATION / MOUNTING OPTION	STUDS
E	100 % tin (RoHS-compliant) radial	None
F	Tin / lead radial	None
G	100 % tin (RoHS-compliant) radial	Yes
H	Tin / lead radial	Yes

MOUNTING STUDS LENGTH CODE	LENGTH
None	Blank
A	0.21"
B	0.27"
C	0.40"
D	0.15"
E	0.18"
F	0.35"

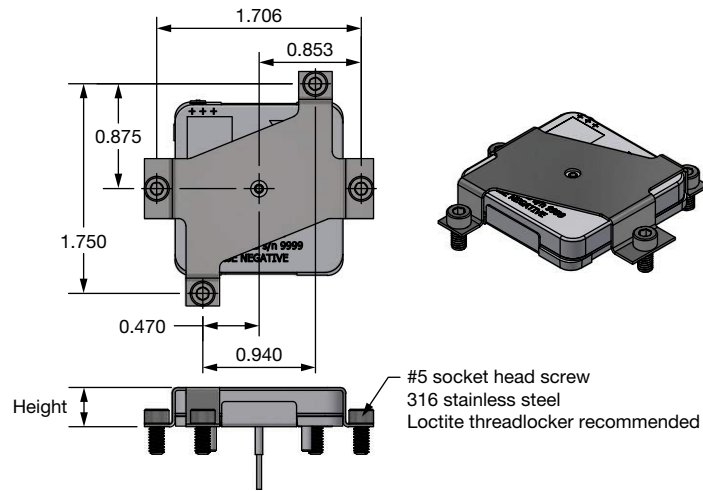
OPTIONAL HOLD-DOWN BRACKETS FOR EP1 PRODUCTS
STANDARD BRACKET

CASE SIZE	HEIGHT	BRACKET CODE	BRACKET WEIGHT WITHOUT FASTENER (g)
A	0.328"	EP1BKT001	6.2
B	0.468"	EP1BKT002	7.0
C	0.618"	EP1BKT003	7.7

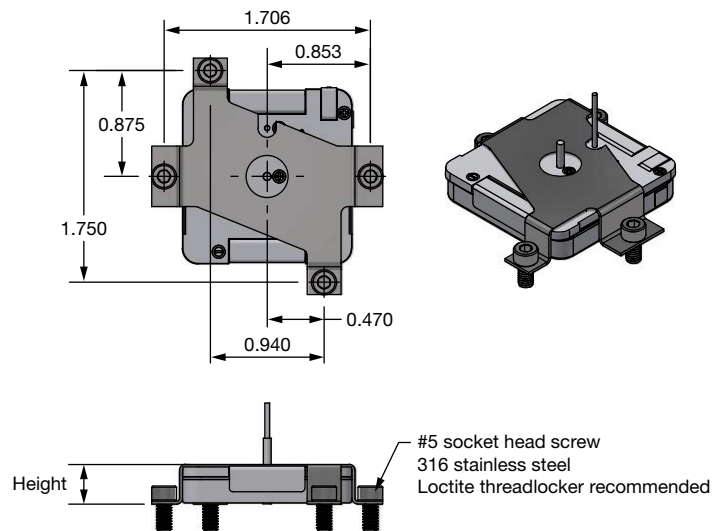
DEAD-BUG BRACKET

CASE SIZE	HEIGHT	BRACKET CODE	BRACKET WEIGHT WITHOUT FASTENER (g)
A	0.328"	EP1BKT004	6.0
B	0.468"	EP1BKT005	6.7
C	0.618"	EP1BKT006	7.3

Note

- For additional instructions, engineering drawings, and 3D models please see section "Links to Additional Resources". The bracket 3D PDF files contain within them all additional CAD documents and CAD models for mounting layout



EP2 STANDARD RATINGS						
CAPACITANCE (μ F)	CASE CODE	PART NUMBER	MAX. ESR AT +25 °C, 1 kHz (Ω)	MAX. DCL AT +25 °C (μ A)	MAX. DCL AT +85 °C (mA)	WEIGHT (g)
25 V_{DC} AT +85 °C; 15 V_{DC} AT +125 °C, SURGE VOLTAGE = 27.5 V_{DC}						
48 000	B ⁽¹⁾	EP2B483(1)025(2)(3)(4)	0.020	250	2.0	80
72 000	C ⁽¹⁾	EP2C723(1)025(2)(3)(4)	0.015	350	2.5	108
35 V_{DC} AT +85 °C; 21 V_{DC} AT +125 °C, SURGE VOLTAGE = 38.5 V_{DC}						
32 000	B ⁽¹⁾	EP2B323(1)035(2)(3)(4)	0.020	250	2.0	80
36 000	B ⁽¹⁾	EP2B363(1)035(2)(3)(4)	0.022	250	2.0	80
40 000	B ⁽¹⁾	EP2B403(1)035(2)(3)(4)	0.022	250	2.0	86
47 000	C ⁽¹⁾	EP2C473(1)035(2)(3)(4)	0.015	350	2.5	110
48 000	C ⁽¹⁾	EP2C483(1)035(2)(3)(4)	0.015	350	2.5	108
58 000	C ⁽¹⁾	EP2C583(1)035(2)(3)(4)	0.017	350	3.0	125
50 V_{DC} AT +85 °C; 30 V_{DC} AT +125 °C, SURGE VOLTAGE = 55 V_{DC}						
17 000	B ⁽¹⁾	EP2B173(1)050(2)(3)(4)	0.025	200	1.5	80
22 000	B ⁽¹⁾	EP2B223(1)050(2)(3)(4)	0.025	250	1.5	80
24 000	B ⁽¹⁾	EP2B243(1)050(2)(3)(4)	0.027	250	1.5	86
23 000	C ⁽¹⁾	EP2C233(1)050(2)(3)(4)	0.017	200	2.5	108
33 000	C ⁽¹⁾	EP2C333(1)050(2)(3)(4)	0.017	350	2.0	108
34 000	C ⁽¹⁾	EP2C343(1)050(2)(3)(4)	0.018	350	2.5	122
37 000	C ⁽¹⁾	EP2C373(1)050(2)(3)(4)	0.020	350	2.5	125
44 000	D ⁽¹⁾	EP2C443(1)050(2)(3)(4)	0.015	450	2.5	134
60 V_{DC} AT +85 °C; 38 V_{DC} AT +125 °C, SURGE VOLTAGE = 66 V_{DC}						
12 600	B ⁽¹⁾	EP2B133(1)060(2)(3)(4)	0.025	150	1.5	86
19 000	C ⁽¹⁾	EP2C193(1)060(2)(3)(4)	0.017	250	2.5	115
63 V_{DC} AT +85 °C; 38 V_{DC} AT +125 °C, SURGE VOLTAGE = 69 V_{DC}						
9400	B	EP2B942(1)063(2)(3)(4)	0.025	150	1.5	86
11 000	B ⁽¹⁾	EP2B113(1)063(2)(3)(4)	0.025	150	1.5	90
12 000	B ⁽¹⁾	EP2B123(1)063(2)(3)(4)	0.025	150	1.5	90
13 000	B ⁽¹⁾	EP2B133(1)063(2)(3)(4)	0.025	150	1.5	92
14 000	C	EP2C143(1)063(2)(3)(4)	0.017	200	2	115
18 000	C ⁽¹⁾	EP2C183(1)063(2)(3)(4)	0.020	250	2.5	120
80 V_{DC} AT +85 °C; 48 V_{DC} AT +125 °C, SURGE VOLTAGE = 88 V_{DC}						
6000	B ⁽¹⁾	EP2B602(1)080(2)(3)(4)	0.027	150	1.5	86
8000	B ⁽¹⁾	EP2B802(1)080(2)(3)(4)	0.030	150	1.5	90
9000	B ⁽¹⁾	EP2B902(1)080(2)(3)(4)	0.030	200	2.0	92
9000	C ⁽¹⁾	EP2C902(1)080(2)(3)(4)	0.018	200	2.0	115
12 000	C ⁽¹⁾	EP2C123(1)080(2)(3)(4)	0.020	250	2.5	120
14 000	C ⁽¹⁾	EP2C143(1)080(2)(3)(4)	0.020	250	2.5	125

Notes

- Part number definitions:
 - Standard capacitance tolerance is 20 % or "M". Contact marketing for availability of 10 % or "K"
 - Standard termination is radial tin / lead, available as "B" or "D".
RoHS-compliant or radial 100 % tin is available as "A" or "C"
 - Standard reliability is "Z" or non-established reliability
 - Standard ESR is "S"
- ⁽¹⁾ Preliminary rating, specification subject to change. Contact marketing for availability



EP2 STANDARD RATINGS						
CAPACITANCE (μ F)	CASE CODE	PART NUMBER	MAX. ESR AT +25 °C, 1 kHz (Ω)	MAX. DCL AT +25 °C (μ A)	MAX. DCL AT +85 °C (mA)	WEIGHT (g)
100 V_{DC} AT +85 °C; 60 V_{DC} AT +125 °C, SURGE VOLTAGE = 110 V_{DC}						
4200	B ⁽¹⁾	EP2B422(1)100(2)(3)(4)	0.030	100	1.5	86
4400	B ⁽¹⁾	EP2B442(1)100(2)(3)(4)	0.030	150	1.5	86
5800	B ⁽¹⁾	EP2B582(1)100(2)(3)(4)	0.035	150	1.5	90
5600	C ⁽¹⁾	EP2C562(1)100(2)(3)(4)	0.020	150	2.5	115
6600	C ⁽¹⁾	EP2C662(1)100(2)(3)(4)	0.020	200	2.0	115
7900	C ⁽¹⁾	EP2C792(1)100(2)(3)(4)	0.025	250	2.5	120
9000	C ⁽¹⁾	EP2C902(1)100(2)(3)(4)	0.025	250	2.5	125
110 V_{DC} AT +85 °C; 66 V_{DC} AT +125 °C, SURGE VOLTAGE = 121 V_{DC}						
4000	B ⁽¹⁾	EP2B402(1)110(2)(3)(4)	0.040	150	1.5	86
6000	C ⁽¹⁾	EP2C602(1)110(2)(3)(4)	0.027	200	2.0	115
125 V_{DC} AT +85 °C; 75 V_{DC} AT +125 °C, SURGE VOLTAGE = 137.5 V_{DC}						
2700	B ⁽¹⁾	EP2B272(1)125(2)(3)(4)	0.045	150	1.5	90
3000	B ⁽¹⁾	EP2B302(1)125(2)(3)(4)	0.045	150	1.5	90
3600	B ⁽¹⁾	EP2B362(1)125(2)(3)(4)	0.050	150	1.5	95
3800	B ⁽¹⁾	EP2B382(1)125(2)(3)(4)	0.050	150	1.5	95
3600	C ⁽¹⁾	EP2C362(1)125(2)(3)(4)	0.025	250	2.5	105
4500	C ⁽¹⁾	EP2C452(1)125(2)(3)(4)	0.025	250	2.5	120
5300	C ⁽¹⁾	EP2C532(1)125(2)(3)(4)	0.035	250	2.5	125
5600	C ⁽¹⁾	EP2C562(1)125(2)(3)(4)	0.035	250	2.5	128

Notes

- Part number definitions:
 - (1) Standard capacitance tolerance is 20 % or "M". Contact marketing for availability of 10 % or "K"
 - (2) Standard termination is radial tin / lead, available as "B" or "D".
RoHS-compliant or radial 100 % tin is available as "A" or "C"
 - (3) Standard reliability is "Z" or non-established reliability
 - (4) Standard ESR is "S"
- (1) Preliminary rating, specification subject to change. Contact marketing for availability



EP1 STANDARD RATINGS						
CAPACITANCE (μ F)	CASE CODE	PART NUMBER	MAX. ESR AT +25 °C, 1 kHz (Ω)	MAX. DCL AT +25 °C (μ A)	MAX. DCL AT +85 °C (mA)	WEIGHT (g)
25 V_{DC} AT +85 °C; 15 V_{DC} AT +125 °C, SURGE VOLTAGE = 27.5 V_{DC}						
30 000	A	EP1A303(1)025(2)(3)(4)(5)	0.030	150	1.5	63
35 V_{DC} AT +85 °C; 21 V_{DC} AT +125 °C, SURGE VOLTAGE = 38.5 V_{DC}						
22 000	A	EP1A223(1)035(2)(3)(4)(5)	0.040	150	1.5	63
50 V_{DC} AT +85 °C; 30 V_{DC} AT +125 °C, SURGE VOLTAGE = 55 V_{DC}						
12 000	A	EP1A123(1)050(2)(3)(4)(5)	0.050	100	1.0	63
13 000	A	EP1A133(1)050(2)(3)(4)(5)	0.050	100	1.0	63
15 000	A	EP1A153(1)050(2)(3)(4)(5)	0.060	100	1.0	67
34 000	C	EP1C343(1)050(2)(3)(4)(5)	0.018	200	2.5	120
63 V_{DC} AT +85 °C; 38 V_{DC} AT +125 °C, SURGE VOLTAGE = 69 V_{DC}						
6000	A	EP1A602(1)063(2)(3)(4)(5)	0.050	100	1.0	63
6600	A ⁽¹⁾	EP1A662(1)063(2)(3)(4)(5)	0.060	100	1.0	66
12 000	B	EP1B123(1)063(2)(3)(4)(5)	0.025	150	1.5	100
18 000	C	EP1C183(1)063(2)(3)(4)(5)	0.020	250	2.5	120
80 V_{DC} AT +85 °C; 48 V_{DC} AT +125 °C, SURGE VOLTAGE = 88 V_{DC}						
4000	A	EP1A402(1)080(2)(3)(4)(5)	0.055	100	1.0	63
4400	A ⁽¹⁾	EP1A442(1)080(2)(3)(4)(5)	0.060	100	1.0	66
7000	B ⁽¹⁾	EP1B702(1)080(2)(3)(4)(5)	0.030	150	1.5	100
8000	B	EP1B802(1)080(2)(3)(4)(5)	0.030	150	1.5	100
12 000	C	EP1C123(1)080(2)(3)(4)(5)	0.025	250	2.5	120
100 V_{DC} AT +85 °C; 60 V_{DC} AT +125 °C, SURGE VOLTAGE = 110 V_{DC}						
3000	A	EP1A302(1)100(2)(3)(4)(5)	0.065	100	1.0	63
3300	A	EP1A332(1)100(2)(3)(4)(5)	0.070	100	1.0	66
4400	B	EP1B442(1)100(2)(3)(4)(5)	0.035	150	1.5	100
5800	B	EP1B582(1)100(2)(3)(4)(5)	0.035	150	1.5	100
125 V_{DC} AT +85 °C; 75 V_{DC} AT +125 °C, SURGE VOLTAGE = 137.5 V_{DC}						
1900	A	EP1A192(1)125(2)(3)(4)(5)	0.100	100	1.0	63
2000	A	EP1A202(1)125(2)(3)(4)(5)	0.100	100	1.0	63
2200	A	EP1A222(1)125(2)(3)(4)(5)	0.110	100	1.0	66
3600	B	EP1B362(1)125(2)(3)(4)(5)	0.050	150	1.5	100
5300	C	EP1C532(1)125(2)(3)(4)(5)	0.035	250	2.5	130

Notes

- Part number definitions:
 - Standard capacitance tolerance is 20 % or "M". Contact marketing for availability of 10 % or "K"
 - Standard termination is radial tin / lead, available as "B", "D", "F", or "H".
RoHS-compliant or radial 100 % tin is available as "A", "C", "E", or "G"
 - Standard reliability is "Z" or non-established reliability
 - Standard temperature range is "S" or -55 °C to +85 °C or +125 °C with voltage derating
 - Standard ESR is "S"
- EP1 B/C ratings are not new for designs
- ⁽¹⁾ Preliminary rating, specification subject to change. Contact marketing for availability

**PERFORMANCE CHARACTERISTICS OF HIGH ENERGY CAPACITORS**

ELECTRICAL PERFORMANCE CHARACTERISTICS	
ITEM	PERFORMANCE CHARACTERISTICS
Operating temperature range	Per MIL-PRF-39006. -55 °C to +85 °C or +125 °C with voltage derating (see Standard Ratings table)
Storage temperature range	Per MIL-PRF-39006. -62 °C to +130 °C
Capacitor tolerance	± 20 % ± 10 % at 120 Hz
ESR	Limits per Standard Ratings table
DC leakage current (DCL max.)	At 25 °C the leakage current shall not exceed values listed in the Standard Rating table.
Reverse voltage	There shall be no continuous reverse voltage. Transient reverse voltage surges are acceptable under the following conditions: a) The peak reverse voltage is equal to or less than 1.0 V and the product of the peak current times the duration of the reverse transient is 0.05 A or less b) The repetition rate of the reverse voltage surges is less than 10 Hz
Surge voltage	The test shall be at 1000 cycles at 110 % of rated voltage at 85 °C. A cycle consists of a 30 s charge and a 330 s discharge through 1000 Ω resistor.
Life test	2000 h at +85 °C

ENVIRONMENTAL CHARACTERISTICS		
ITEM	TEST AND CONDITIONS	COMMENTS
Hermeticity	MIL-STD-202, method 112 C/IIIa	The capacitor shall be hermetically sealed such that the case does not leak electrolyte or vent any gas when exposed to a vacuum.
Moisture resistance	MIL-STD-202, method 106	6 V polarity
Altitude	MIL-STD-202, method 105, test condition D	100 000 feet test
Fungus	MIL-PRF-39006	The capacitor materials shall not support fungus growth and shall not be a nutrient to fungus.

MECHANICAL PERFORMANCE CHARACTERISTICS		
ITEM	TEST AND CONDITIONS	COMMENTS
Thermal shock	MIL-STD-202, method 107, test condition A	Thermal shock shall be in accordance with MIL-PRF-39006 when tested for 30 cycles
Shock	MIL-STD-202, method 213, test condition G	11 ms, 50 g
Vibration - high frequency	MIL-STD-202, method 204, test condition D	12 sweeps/axis, 20 g peak
Vibration - random	MIL-STD-202, method 214, test condition II, letter E	1.5 h/axis, 19.64 g
Resistance to solder heat	MIL-STD-202, method 210, test conditions A and B	
Solderability	MIL-STD-202, method 208, ANSI/J-STD-002, test A	
Terminal strength	MIL-STD-202, method 211	The capacitor terminals must withstand a 5 pound pull test for 5 s to 10 s. The capacitor must not be visibly damaged and the electrical characteristics must not be affected.
Part markings	MIL-STD-202, method 215	The capacitor shall be permanently and legibly marked on the circumference of the case. The markings shall be resistant to solvents.
Weight (mass)		See Standard Ratings table
Seal	MIL-PRF-39006	
MSL	J-STD-033	Not applicable
Packaging	MIL-PRF-39006	All units are shipped in individual bulk packages.
Stud mounting		Tighten nuts only ½ to ¾ turn beyond point of initial contact, equivalent to 24 to 28 maximum inch-ounces torque. Maximum pre-load tension ~ 15 pounds. Lock washers are not recommended; use an adhesive lock nut conforming to MIL-S-22473E, grade A - red



Disclaimer

ALL PRODUCT, PRODUCT SPECIFICATIONS AND DATA ARE SUBJECT TO CHANGE WITHOUT NOTICE TO IMPROVE RELIABILITY, FUNCTION OR DESIGN OR OTHERWISE.

Vishay Intertechnology, Inc., its affiliates, agents, and employees, and all persons acting on its or their behalf (collectively, "Vishay"), disclaim any and all liability for any errors, inaccuracies or incompleteness contained in any datasheet or in any other disclosure relating to any product.

Vishay makes no warranty, representation or guarantee regarding the suitability of the products for any particular purpose or the continuing production of any product. To the maximum extent permitted by applicable law, Vishay disclaims (i) any and all liability arising out of the application or use of any product, (ii) any and all liability, including without limitation special, consequential or incidental damages, and (iii) any and all implied warranties, including warranties of fitness for particular purpose, non-infringement and merchantability.

Statements regarding the suitability of products for certain types of applications are based on Vishay's knowledge of typical requirements that are often placed on Vishay products in generic applications. Such statements are not binding statements about the suitability of products for a particular application. It is the customer's responsibility to validate that a particular product with the properties described in the product specification is suitable for use in a particular application. Parameters provided in datasheets and / or specifications may vary in different applications and performance may vary over time. All operating parameters, including typical parameters, must be validated for each customer application by the customer's technical experts. Product specifications do not expand or otherwise modify Vishay's terms and conditions of purchase, including but not limited to the warranty expressed therein.

Hyperlinks included in this datasheet may direct users to third-party websites. These links are provided as a convenience and for informational purposes only. Inclusion of these hyperlinks does not constitute an endorsement or an approval by Vishay of any of the products, services or opinions of the corporation, organization or individual associated with the third-party website. Vishay disclaims any and all liability and bears no responsibility for the accuracy, legality or content of the third-party website or for that of subsequent links.

Except as expressly indicated in writing, Vishay products are not designed for use in medical, life-saving, or life-sustaining applications or for any other application in which the failure of the Vishay product could result in personal injury or death. Customers using or selling Vishay products not expressly indicated for use in such applications do so at their own risk. Please contact authorized Vishay personnel to obtain written terms and conditions regarding products designed for such applications.

No license, express or implied, by estoppel or otherwise, to any intellectual property rights is granted by this document or by any conduct of Vishay. Product names and markings noted herein may be trademarks of their respective owners.