

FCI CONFIDENTIAL



This document is the property of and embodies CONFIDENTIAL and PROPRIETARY information of FCI. No part of the information shown on this document may be used in any way or disclosed to others without the written consent of FCI. Copyright FCI.

PLATING ACTIVE ZONE

CHARACTERISTICS

500 mating/unmating Ni: 2µm 0/+2µm Au: 1.27µm min	500 mating/unmating Cu flash Ni P : 2µm 0/+2µm Au: 0.2µm min (equivalent 0.8µm Au)	200 mating/unmating Cu flash Ni P : 2µm 0/+2µm Au: 0.15µm min (equivalent 0.4 µm Au)	CURRENT max A	AWG WIRE	mm <sup>2</sup> AREA	∅A +0 -0.05	∅B+0 -0.05	Clip colour
8638PPC4007LF	8638PPC4006LF	8638PPC4005LF	40	8-10	5-8	4.70	5.50	BLUE
8638PPC3007LF	8638PPC3006LF	8638PPC3005LF	30	9	6	3.75	4.75	WHITE
8638PPC2007LF	8638PPC2006LF	8638PPC2005LF	20	12-14	2-3	2.80	3.70	RED
8638PPC1007LF	8638PPC1006LF	8638PPC1005LF	10	16-18	0.9-1.3	1.80	2.55	BLACK

NOTE: RoHS INFORMATIONS

- The "LF" products meet European union Directives and regulations as described in GS-22-008
- Termination plating spec: Sn pure matte
- Packaging spec: see GS-14-920

Materials and finish

Active zone: CuZn40 Pb3. Plating see table  
 Termination zone (crimping sleeve): CuZn40Pb3  
 Plating 2µm 0/+2µm Cu - 3µm 0/+3µm Tin pure matte  
 Clip : Thermoset plastic

Technical characteristics

Peak voltage: 750 Veff.  
 Operating voltage: 500 Veff.  
 Temperature range -55 °C +125 °C  
 Packaged per 100  
 Current capability : see table

Mechanical characteristics :

Crimping test: according to MILC39029  
 Mechanical endurance: 200 or 500 matings/unmatings (see table).  
 Contact insertion force in insulator:  
 60N maxi in a hole of 4.80 mm

Examination of product:

Remove all burrs and sharp edges 0.08 maxi  
 No scratch allowed

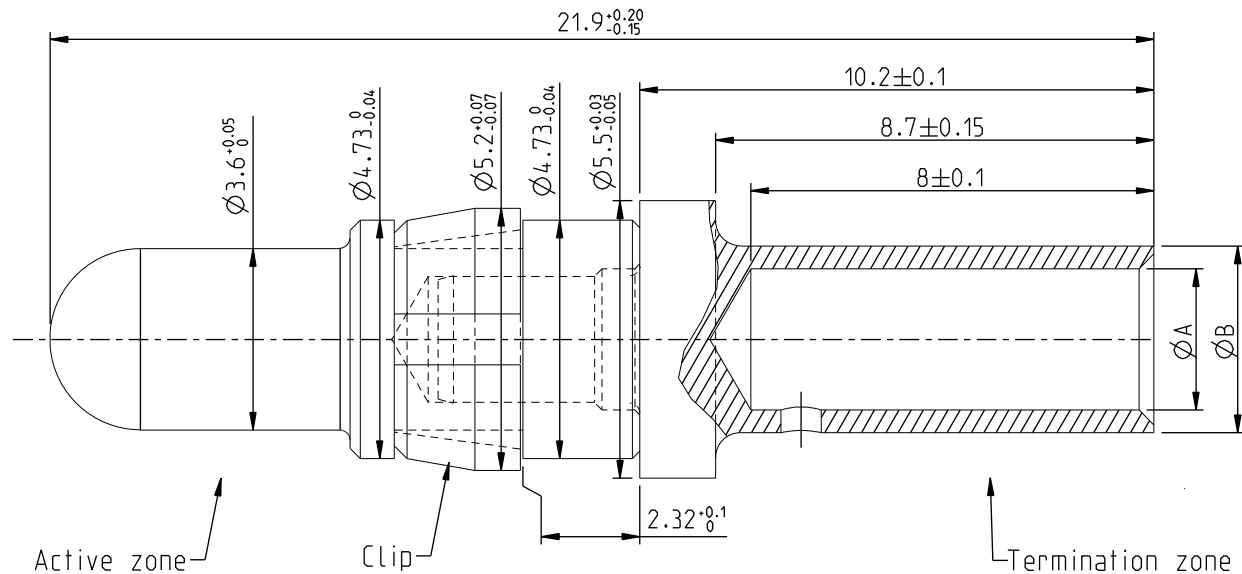

Mark with		Material		SEE TABLE		Spec ref			
		Mat code				surface -		tolerance	
		Heatreat		-		ISO 1302		405	
		Plating/Finish		SEE TABLE				1101	
Or		JARRY		2002/02/28		Product family		D-sub	
Eng		PESSON		2002/02/28		Model Name		8638PPC200XLF	
Chr		LEGARE		2002/02/28		Model Revision		1	
Appr		LEGARE		2002/02/28		REL Level		CONCEPT	
rev		ecn no		dr		date		size	
N		F10-0076		LSA		2010/07/22		A3	
H		LS06-0097		LGO		2006/07/27		Scale	
J		LS06-0029		MPE		2008/01/28		10:1	
K		F09-0054		LSA		2009/06/10			
L		F10-0031		GPE		2010/04/12			
M		F10-0065		LSA		2010-06-25			
Title		MALE CONTACT				dwg no		C01-8638-0325	
FOR CRIMPED CONNECTION		FCI				Customer		sheet 1 of 1	
Rev.		N				Customer		-	

REV C - 2010-03-28