

Country of Origin : China  
 Operating Temperature : 0~40 [°C]  
 Dimension : 93.5 x 46 x 35.8 [mm]  
 Certified AC Plugs: EU, UK, USA/Japan, Aus, Korea, Brazil, Argentina, China, India, S. Africa  
 Efficiency level (ErP) : VI



**GREEN MODE** **RoHS**



Approvals / Marks :



### Specifications

Model	Voltage DC [V]	Loading [A]	Max. Power [W]	Ripple / Noise [mV] p-p	Connector [mm]
SYS1541-1505-Wxx*	5	0~3.0	15	180	2.1x5.5x11
SYS1541-1809-Wxx*	9	0~2.0	18	180	2.1x5.5x11
SYS1541-2412-Wxx*	12	0~2.0	24	180	2.1x5.5x11
SYS1541-2415-Wxx*	15	0~1.6	24	200	2.1x5.5x11
SYS1541-2418-Wxx*	18	0~1.33	24	240	2.1x5.5x11
SYS1541-2424-Wxx*	24	0~1.0	24	300	2.1x5.5x11

### Features:

Certified plugs

Wxx = W2E - Europe | W3U - England | W2 - USA, Canada, Japan, Taiwan | W2A - Australia | W2B - Brazil | W2G - Argentina | W2C - China | W2K - Korea | W2I - India | W3S - South Africa  
 Output connector: standard: 2.1 x 5.5 x 11mm or customer requirement | Regulated Output With Low Ripple Noise | Safety Agency Requirements and EMI/EMS Certified  
 Private Label Marking Available | Modified and Custom Design Available | 2 Years Warranty

OUTPUT	
Turn delay	5000ms max@AC low line input@output full load
Hold up time	5ms min@AC nominal input@output full load (>half cycle)
Efficiency (Normal)	Meet CEC,DOE,ERP,MEPS Level VI @115v/60HZ,230V/50HZ
Transient response (dv,tmax)	0.4V dv max At AC nominal input loading from 20%load to 80%load 16ms tmax Dynamic rise time 10us max,duty 40ms max,Dynamic load step is slew rate of 0.5A/us
Power out.Limit	Peak 28w
Burn in limit	Full load 2 Hours
Power consumption	Less than 0.075W ms max. At AC nominal input@output min load
INPUT	
Voltage	(90~264)VAC
Frequency	(47~63)hz
Current	0.5A rms@AC low line input and DC output full load
Inrush Surge Current (cold start)	40/60A max@power supply cold start,ambient temperature 25°C @115Vac/230Vac nominal AC input
leakage current	0.25mA Max
PROTECTION	
Over current/ Short protection	The power supply will self-protect any output to ground. And auto recovery when abnormal circuit faults remove. An output short circuit is defined as any output impedance of less than 0.1 ohms.
Over Voltage	The power supply will be auto recovered when faults remove
Input protection	F1:1A 250V Fuse The power supply shall be protected against power line surges and any abnormal condition
No Load protection	The power supply is provided with no load operation to prevent the power supply and system from damage.
Protection class	II, (ITU-T K.21 Surge 6KV on request)

EMC	
Meet EN550022 class B, FCCpart 15 Sub part B class B	
EN 60950-1:2006+All   LVD2006/95/EC   IEC 60950-1:2005	
SAFETY	
UL   GS   CB   CE   FCC   CCC   BSMI   EK-Mark (2412/2424)   SAA   RCM   PSB (2424)   EAC   INMETRO   BIS (2424)	
OTHERS	
Dielectric Strength (Hi-pot)	Primary to Secondary:3000VAC 10mA/60S
M.T.B.F	500,000 Calculated Hours at 25°C, by Telcordia SR-332
Cable Length	1500mm (5 feet) standard cable or as required
PLD (power line disturbance)	Line power surge   Line voltage SAG-more info on request
Cooling method	Natural Convection Cooling
Housing material	PC
Temperature coefficient:	<±0.5%/°C
ENVIRONMENT	
Temperature	Operating: 0~40°C / Storage: -20~-85°C
Humidity	Operating: 8%~90%RH / Storage: 5%~95% RH non condensing
WEIGHT	
NW: 135g/pc	
GW: 12.5kg/box	
PACKING	
PE plastic bag	63 pcs/1 box

**Mechanical case specification:**

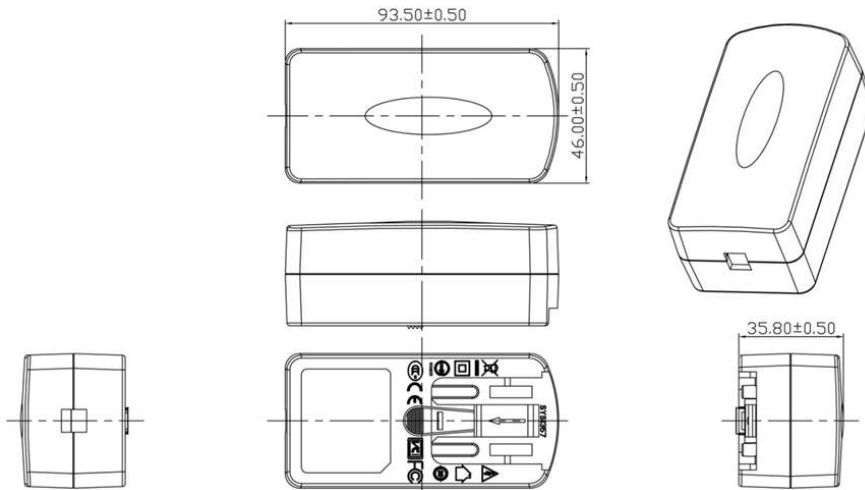

**Mechanical specification (country housing):**

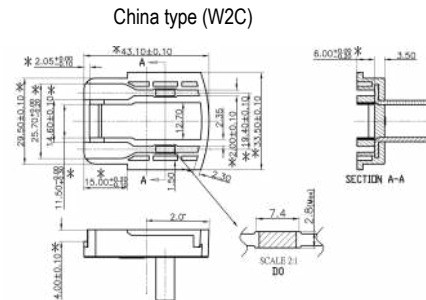
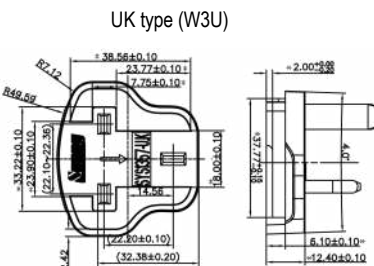
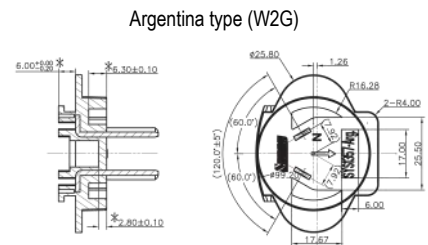
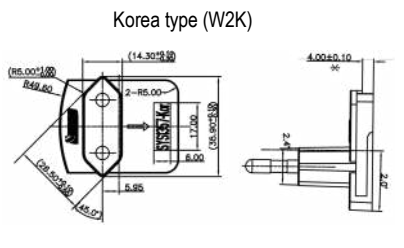
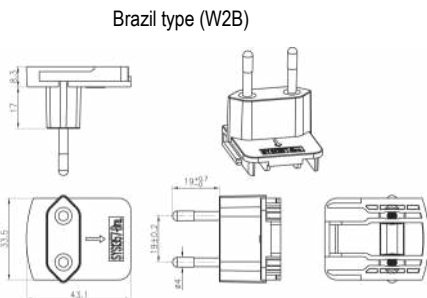
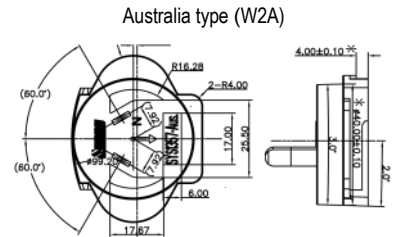
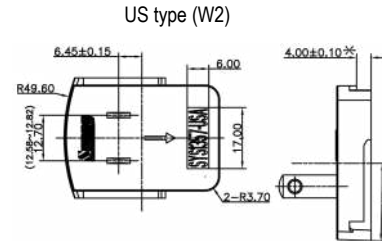
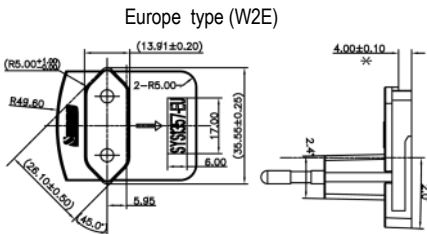

**Cable specification:**

1185#18\*1C | 1500mm

