

DESCRIPTION

The EV2617H-L-00A is an evaluation board for MP2617H, a 3A/1.6MHz 1-cell switching charger with power path management.

MP2617H integrates a synchronous BUCK regulator for powering the system output and charging the battery. For USB mode, the input current limit can be programmed to 450mA and 825mA via the logic pins to cover the USB2.0 and USB3.0. For the adapter input, the input current is also limited to avoid overloading the adapter. The value can be programmed up to 3A.

MP2617H regulates the system voltage for powering the external load and charge the battery simultaneously. When the current limit is hit, the system load is satisfied in priority, the charger will take the leavings to charge the battery. Additionally, the smart power path control will make the charge switch as a connection from battery to the system to supplement power the load if the system requirement increases over the input limited power or the input is removed.

ELECTRICAL SPECIFICATION

Parameter	Symbol	Value	Units
Input Voltage	V_{IN}	4.5 to 14	V
Battery Voltage	V_{BATT}	0 to 4.2	V
SYS Voltage	V_{SYS}	3.5 to 4.4	V
Input Current Limit	I_{IN} Limit	1.5	A
Charge Current	I_{CHG}	2	A
SYS Current	I_{SYS}	0-3	A
V_{IN} Clamp Voltage	V_{IN} Limit	4.71	V

FEATURES

- 4V to 14V Operating Input Voltage
- Smart Power Path Management
- Five Control Loops: Input Current Limit, Input Voltage Limit, Constant Charge Current, Terminal Battery Control and Thermal Fold-Back.
- 1.6MHz Switching Frequency
- Programmable Input Current Limit
- Programmable Charge Current
- Single Inputs for USB and AC adapter
- Cover USB2.0 and USB3.0 Input Specification
- Fully Integrated Power Switches
- No External Blocking Diode and Sense Resistor Required
- Charging Operation Indicator
- Built-in Programmable Charging Timer
- Thermal Limiting Regulation on Chip
- Battery Temperature Monitor

APPLICATIONS

- Smart Phones
- Portable Hand-Held Terminals
- E-BOOK
- GPS
- TPC
- MIFY

All MPS parts are lead-free and adhere to the RoHS directive. For MPS green status, please visit MPS website under Products, Quality Assurance page.
 "MPS" and "The Future of Analog IC Technology" are registered trademarks of Monolithic Power Systems, Inc.

EV2617H-L-00A EVALUATION BOARD

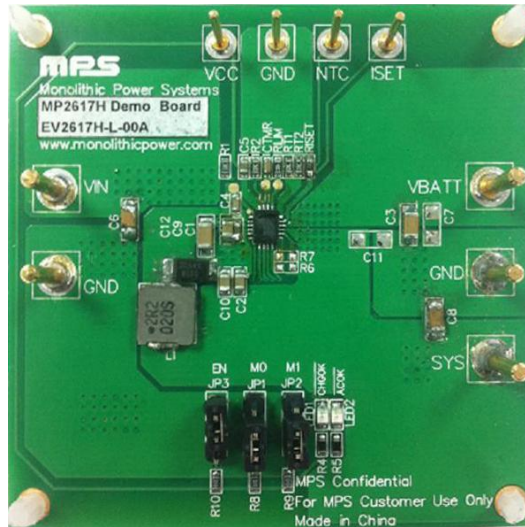

(L x W x H) 2.48" x 2.48" x 0.063"
(6.3cm x 6.3cm x 0.16cm)

Board Number	MPS IC Number
EV2617H-L-00A	MP2617H

EVALUATION BOARD SCHEMATIC

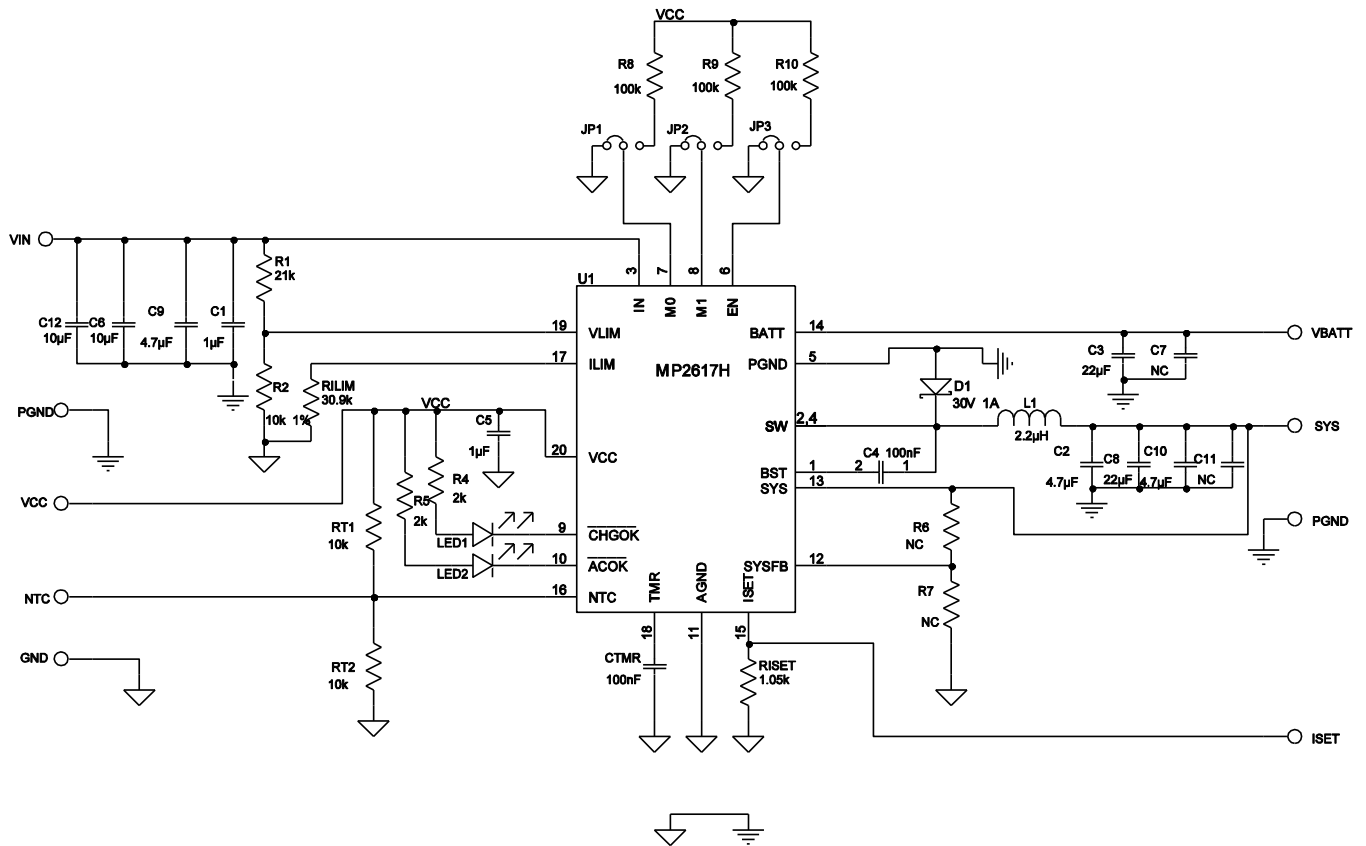

EV2617H-L-00A BILL OF MATERIALS

Qty	Ref	Value	Description	Package	Manufacturer	Manufacturer P/N
2	C1, C5	1 μ F	Ceramic Capacitor; 25V;X7R	0603	muRata	GRM188R71C105KA12D
3	C2, C9, C10	4.7 μ F	Ceramic Capacitor; 25V;X5R	0805	muRata	GRM21BR61C475KA12L
2	C3, C8	22 μ F	Ceramic Capacitor; 25V;X7R	1206	muRata	GRM31CR61E226KE15
2	C4, CTMR	100nF	Ceramic Capacitor; 50V;X7R	0603	muRata	GRM188R71H104KA93D
2	C6, C12	10 μ F	Ceramic Capacitor; 25V;X5R	1206	muRata	GRM31CR61E106KA12L
2	C7, C11	NC				
1	L1	2.2 μ H	Inductor, 37mOhm;5.1A	SMD	TOKO	FDA0620-2R2M
1	LED1	BL- HUF35A- TRB	LED;红光;	0805	BRIGHT LED	BL-HUF35A-TRB
1	LED2	BL- HGE35A- TRB	LED;绿光;	0805	BRIGHT LED	BL-HGE35A-TRB
1	R1	21k	Film Resistor;1%;	0603	Yageo	RC0603FR-0721KL
3	R2, RT1, RT2	10k	Film Resistor;1%;	0603	Yageo	RC0603FR-0710KL
2	R4, R5	2k	Film Resistor;1%;	0603	Yageo	RC0603FR-072KL
2	R6, R7	NC				
3	R8, R9, R10	100k	Film Resistor;5%;	0603	Yageo	RC0603JR-07100KL
1	RILIM	30.9k	Film Resistor;1%	0603	Yageo	RC0603FR-0730K9L
1	RISET	1.05k	Film Resistor;1%	0603	Yageo	RC0603FR-071K05L
1	D1	30V/1A	Schottky Diode	SMA	Diodes	B130
1	U1				MPS	MP2617H
5	VIN, GND, VBATT, VSYN, GND		2.0 公针			
4	VCC, GND, NTC, ISET		1.0 公针			
2	JP1, JP2, JP3		2.54mm 排针			

PRINTED CIRCUIT BOARD LAYOUT

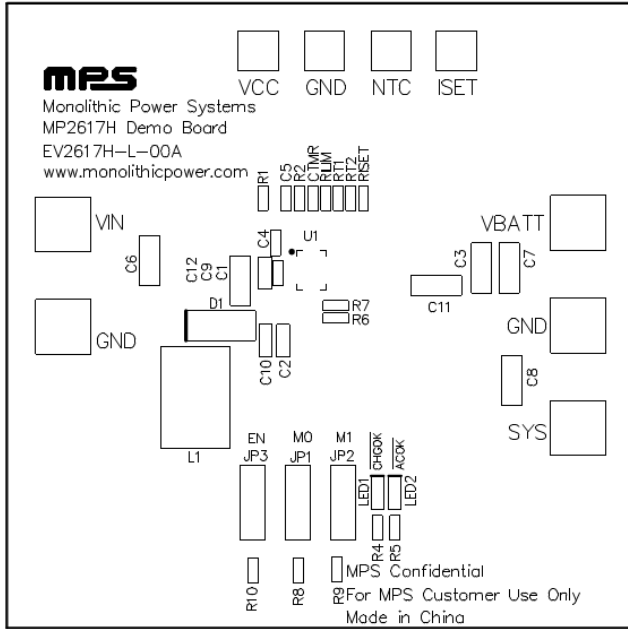

Figure 1— Top Silk Layer

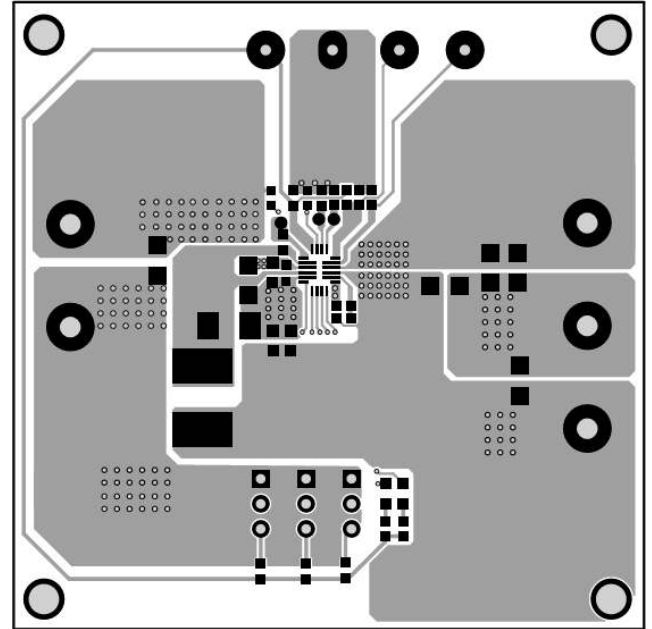

Figure 2—Top Layer

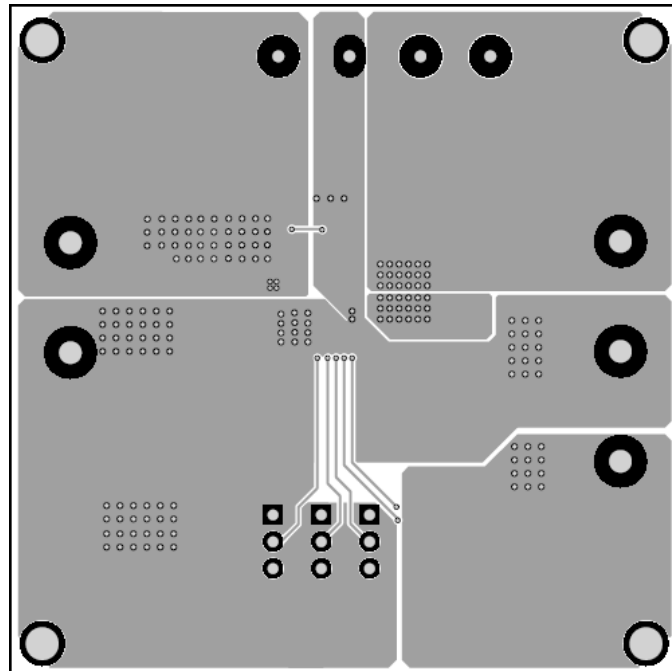

Figure 3—Bottom Layer

QUICK START GUIDE

This board is used for the evaluation of MP2617H applications which can charge a single-cell Li-ion battery and powers the system load simultaneously. The board layout accommodates most commonly used capacitors.

1. The EV2617H-L-00A evaluation board can receive Adapter input and USB input. Setting M0 and M1 in different logic can set the input in different spec. For the default setting, keep M0 and M1 float, set the Input for a 2A adapter input. The board is in default setting. Following table shows how to set the input spec through M0 and M1 according to different application conditions.

Table 1—Input Setting through M0 and M1 States

M0	M1	Mode	Input Current Limit
Low	Low	USB2.0 Mode (VIN=5V)	450mA
Low	High	USB3.0 Mode (VIN=5V)	825mA
High	Low	Programmable Mode (VIN=12V)	0-3A
High/Float	High/Float	Default Mode (VIN=12V)	2A

For EV2617H-L-00A, change the states of M0 and M1 is very easy through the JP1 and JP2. For the program mode, the input current limit can be set by the formula found in the datasheet.

2. JP3 is used to set the EN logic, which can control MP2617H to totally shutdown with VIN added. Logic high which means connect EN to VCC through JP3 can disable MP2617H. Float it or connect it to GND can enable the part.

3. SYS is the output of the DC-DC, which powers the load adding the pin directly and charges the battery through the internal linear charger from SYS to BATT pin. It is default in 3.6V with $V_{BATT} < 3.4V$ and equals to $200mV + V_{BATT}$ otherwise. It can also be programmed to any value lower than 4.4V by R6 and R7 through the following formula:

$$V_{SYS} = V_{SYS_REF} \times \frac{R6 + R7}{R7}$$

V_{SYS_REF} is 1.152V.

4. Connect a real battery or battery simulator to BATT pin to see the charging operation of MP2617H. When BATT pin is float, MP2617H can detect the no battery condition and set VSYS constant at 4.4V if R6 and R7 is float, or the value programmed by R6 and R7. Charge current can be set through the following formula:

$$I_{CHG} = 1.15 \times \frac{1800}{R_{SET} (k\Omega)} (mA)$$

5. If the application only applies the DC-DC of MP2617H, will not use it charging a battery, which means battery pin is always float while requires V_{SYS} to be constant at the set value. User can connect SYS pin and BATT pin together to short the internal linear charger to realize this application.

6. More detail application information please refer to the datasheet.

NOTICE: The information in this document is subject to change without notice. Users should warrant and guarantee that third party Intellectual Property rights are not infringed upon when integrating MPS products into any application. MPS will not assume any legal responsibility for any said applications.