

DRAWING MADE IN THIRD ANGLE PROJECTION

3

2

1

LOC DF 50

THIS DRAWING IS UNPUBLISHED. RELEASED FOR PUBLICATION 19
 © COPYRIGHT 19 BY AMP INCORPORATED, HARRISBURG, PA. ALL INTERNATIONAL RIGHTS RESERVED. AMP PRODUCTS MAY BE COVERED BY U.S. AND FOREIGN PATENTS AND/OR PATENTS PENDING.

		REVISIONS				
P	F	ZONE	LTR	DESCRIPTION	DATE	APPROVED
0	✓		0	RELEASE.	RPH	3/23/84
✓			A	REV PER 0600-0043-93	TE	DE. 5-24-93

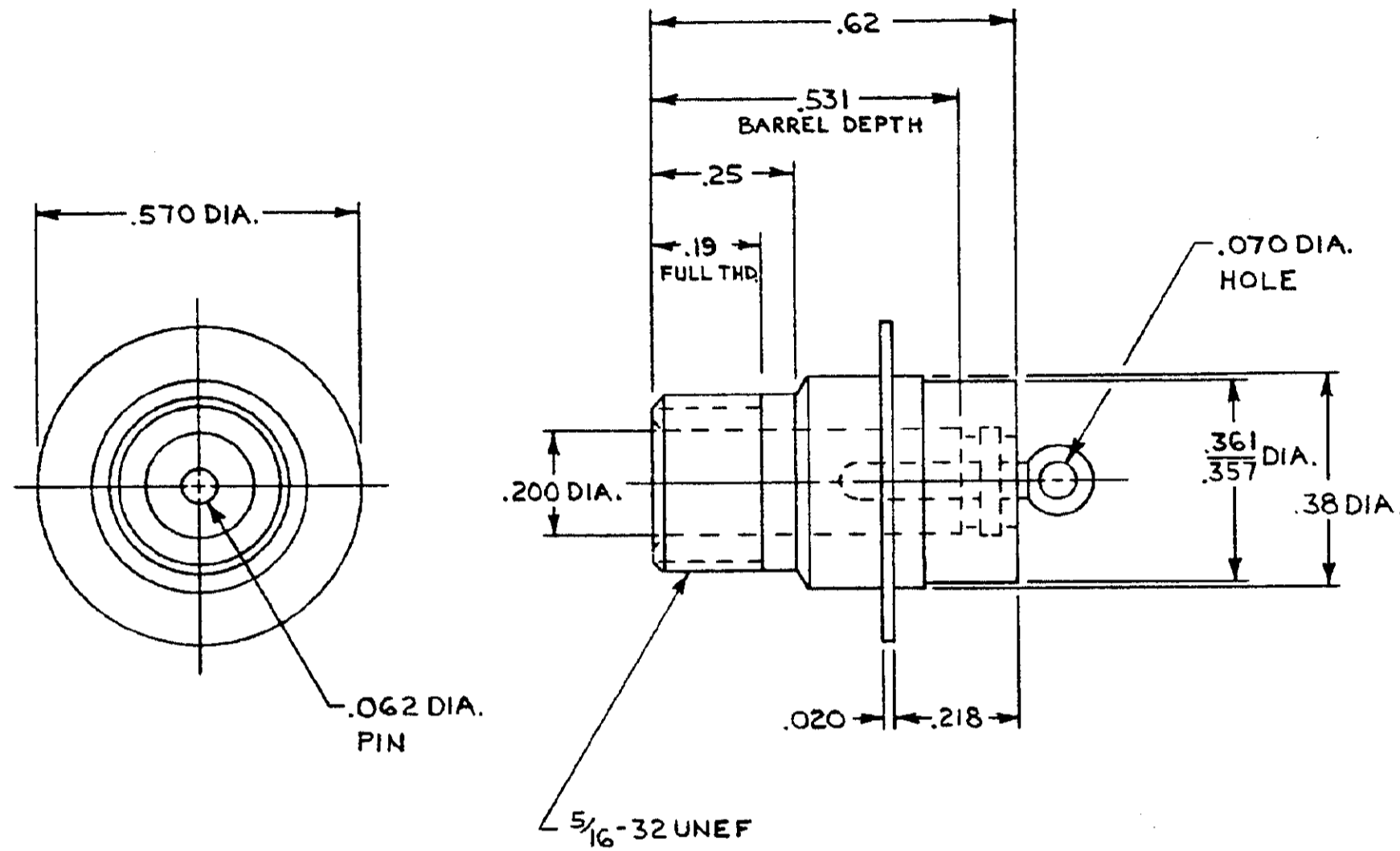

1. THIS RECEPTACLE IS HERMETICALLY SEALED.
2. SCREW THREAD MEASUREMENT IN ACCORDANCE WITH H28 HANDBOOK. (3 WIRE METHOD). USING WIRE .01804 DIA. MEASUREMENT OVER WIRE SHALL BE .318/.307.

UNLESS OTHERWISE SPECIFIED DIMENSIONS ARE IN INCHES. TOLERANCES ON: DECIMALS XX±.01 XXX±.005		CONTRACT NO		AS SHOWN		867942-1	
MATERIAL MOLDED GLASS EPOXY		DR R. B. Hepner 3-23-84		DESCRIPTION		PART NO	
FINISH BLACK		CHK		NAME		AMP AMP INCORPORATED Harrisburg, Pa. 17105	
		APPD W. J. [Signature] 3/23/84		FLANGED RECEPTACLE LGH-1/2			
		DSGN APPD		SIZE C	FSCM NO 00779	DRAWING NO 867942	
		OTHER APPD		SCALE NTS		SHEET 1/1	

CUSTOMER DRAWING