

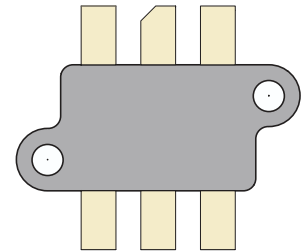

RF POWER VERTICAL MOSFET

The VRF191 is a gold-metallized silicon n-channel RF power transistor designed for broadband commercial and military applications requiring high power and gain without compromising reliability, ruggedness, or inter-modulation distortion.



T11

FEATURES

- Improved Ruggedness $V_{(BR)DSS} = 270V$ min
- 150W with 22dB Typical Gain @ 30MHz, 100V
- 150W with 14dB Typical Gain @ 150MHz, 100V
- Excellent Stability & Low IMD
- Common Source Configuration
- RoHS Compliant 
- 5:1 Load VSWR Capability at Specified Operating Conditions
- Nitride Passivated
- Refractory Gold Metallization
- High Performance Flangeless Package

Maximum Ratings

 All Ratings: $T_c = 25^\circ C$ unless otherwise specified

Symbol	Parameter	VRF191	Unit
V_{DSS}	Drain-Source Voltage	270	V
I_D	Continuous Drain Current @ $T_c = 25^\circ C$	12	A
V_{GS}	Gate-Source Voltage	± 40	V
P_D	Total Device dissipation @ $T_c = 25^\circ C$	300	W
T_{STG}	Storage Temperature Range	-65 to 200	°C
T_J	Operating Junction Temperature	200	

Static Electrical Characteristics

Symbol	Parameter	Min	Typ	Max	Unit
$V_{(BR)DSS}$	Drain-Source Breakdown Voltage ($V_{GS} = 0V, I_D = 100mA$)	270	280		V
$V_{DS(ON)}$	On State Drain Voltage ($I_{D(ON)} = 5A, V_{GS} = 10V$)		3.5	5.0	
I_{DSS}	Zero Gate Voltage Drain Current ($V_{DS} = 200V, V_{GS} = 0V$)			1.0	mA
I_{GSS}	Gate-Source Leakage Current ($V_{DS} = \pm 20V, V_{GS} = 0V$)			1.0	μA
g_{fs}	Forward Transconductance ($V_{DS} = 10V, I_D = 5A$)	4.0	6		mhos
$V_{GS(TH)}$	Gate Threshold Voltage ($V_{DS} = 10V, I_D = 100mA$)	2.9	3.6	4.4	V

Thermal Characteristics

Symbol	Characteristic	Min	Typ	Max	Unit
$R_{\theta JC}$	Junction to Case Thermal Resistance			0.35	
$R_{\theta JS}$	Junction to Sink (Use high efficiency thermal joint compound and planar heat sink surface.)		.45		°C/W

 **CAUTION:** These Devices are Sensitive to Electrostatic Discharge. Proper Handling Procedures Should Be Followed.

Dynamic Characteristics

VRF191

Symbol	Parameter	Test Conditions	Min	Typ	Max	Unit
C_{iss}	Input Capacitance	$V_{GS} = 0V$ $V_{DS} = 100V$ $f = 1MHz$		460		pF
C_{oss}	Output Capacitance			80		
C_{rss}	Reverse Transfer Capacitance			6		

Functional Characteristics

Symbol	Parameter	Test Conditions	Min	Typ	Max	Unit
G_{PS}	$f_1 = 30MHz, V_{DD} = 100V, I_{DQ} = 250mA, P_{out} = 150W$		18	22		dB
G_{PS}	$f_1 = 150MHz, V_{DD} = 100V, I_{DQ} = 250mA, P_{out} = 150W$			14		
η_D	$f_1 = 30MHz, V_{DD} = 100V, I_{DQ} = 250mA, P_{out} = 150W$			50		%
ψ	$f_1 = 30MHz, V_{DD} = 100V, I_{DQ} = 250mA, P_{out} = 150W$ Phase Angles	5:1 VSWR - All	No Degradation in Output Power			

1. To MIL-STD-1311 Version A, test method 2204B, Two Tone, Reference Each Tone

Microsemi reserves the right to change, without notice, the specifications and information contained herein.

Typical Performance Curves

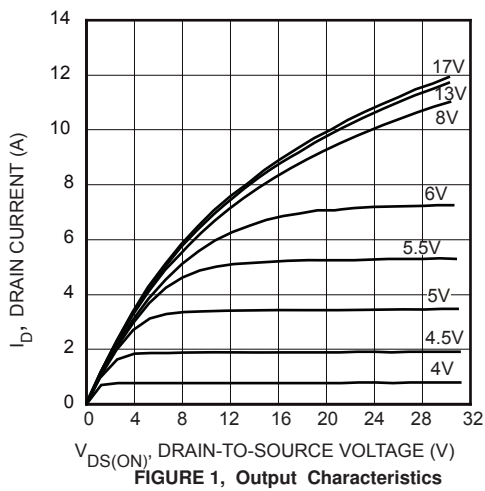

FIGURE 1, Output Characteristics

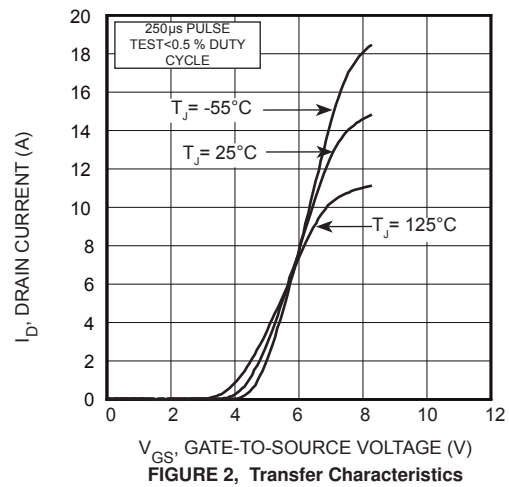

FIGURE 2, Transfer Characteristics

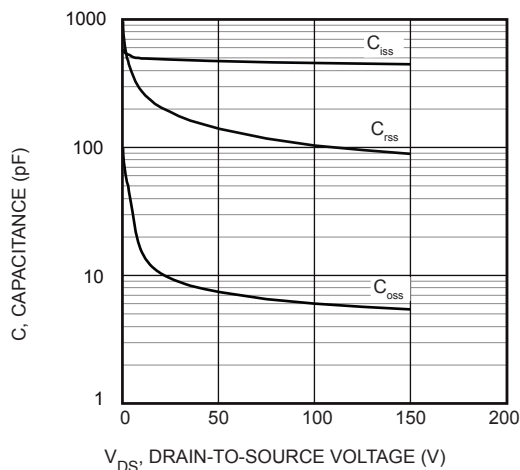

FIGURE 3, Capacitance vs Drain-to-Source Voltage

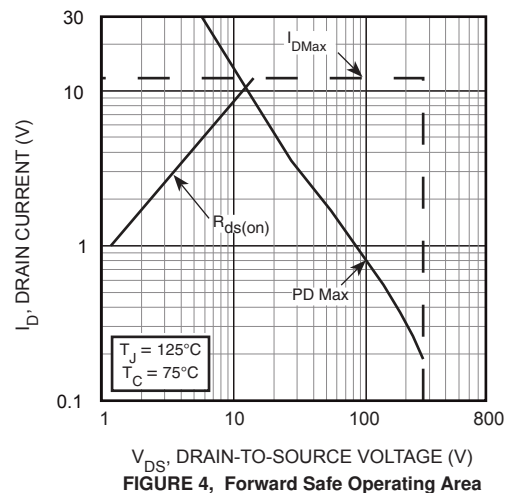

FIGURE 4, Forward Safe Operating Area

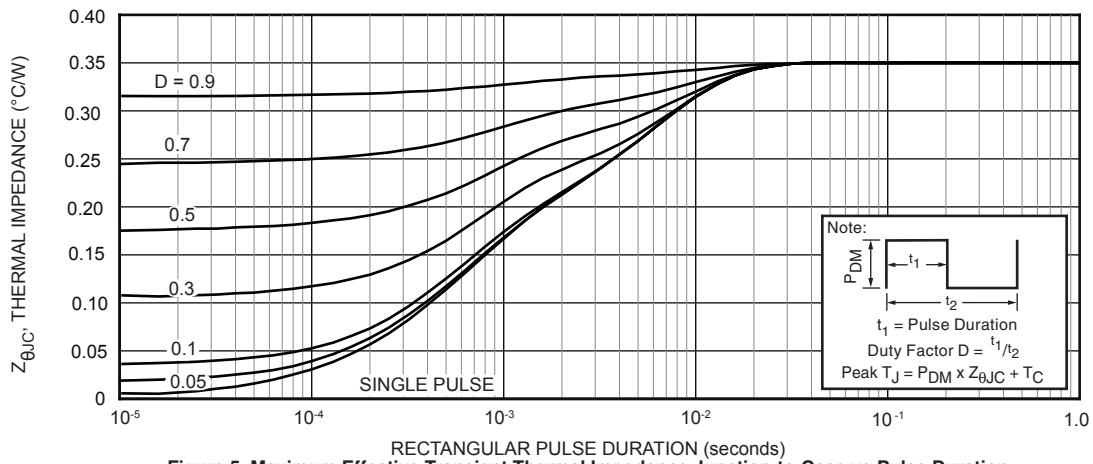

Figure 5. Maximum Effective Transient Thermal Impedance Junction-to-Case vs Pulse Duration

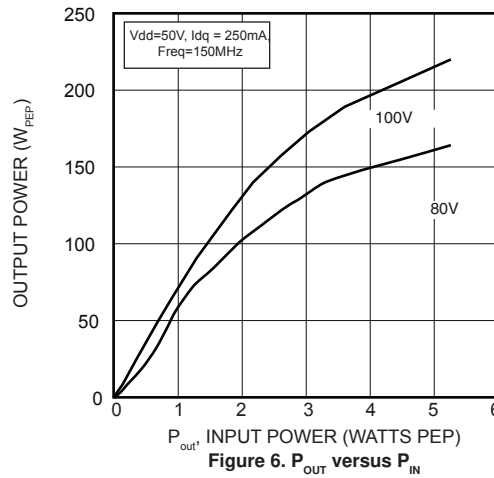
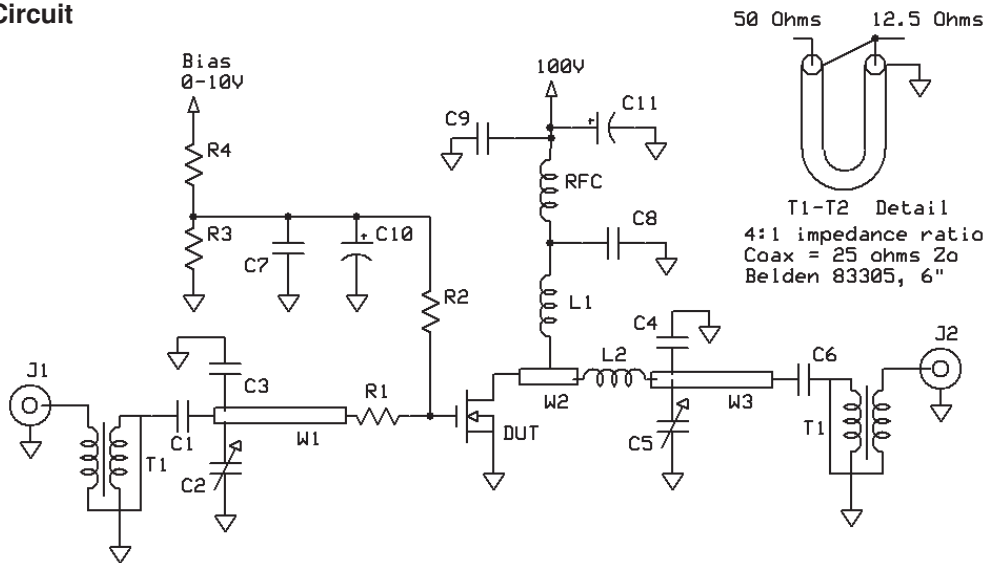
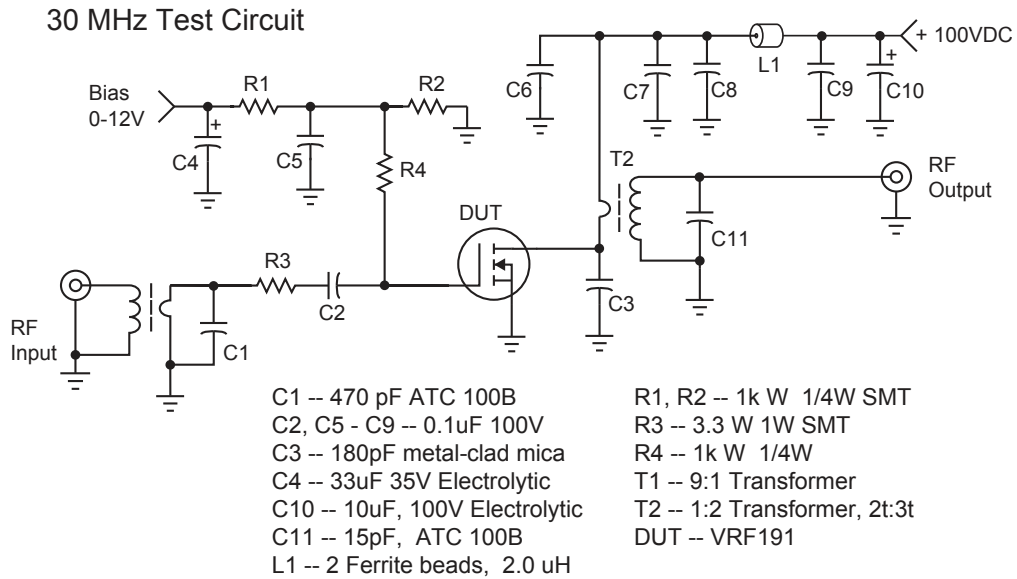

Figure 6. P_{out} versus P_{in}

150 MHz Test Circuit



- C1, C6 - 910pF ATC 100B
- C2, C5 - ARCO 406 ~70pF
- C3 - 110 pF ATC 100B
- C4 - 120 pF ATC 100B
- C7-C9 - 0.1uF 100V 1206 SMT
- C10 - 1 uF 15 WV tant
- C11 - 15uF 100V Elect
- L1 - 6t #18 0.25" dia tight
- L2 - 1.2" #16 into hairpin 18 nH
- R1 - 1 ohm 1W SMT
- R2 - R4 - 2200 ohm 1/4W
- RFC Fair-Rite 2961666631 (VK200-4B)
- T1 T2 - 4:1 transformer - see detail
- W1 Stripline .25 x 1"
- W2 Stripline .25 x 0.50"
- W3 Stripline .25" x 75" (<30 ohm)
- DUT - VRF191



T11 Package Outline

